

HYOSUNG

HYOSUNG

HYOSUNG MOTORS & MACHINERY INC.

WOW90

SERVICE MANUAL

SERVICE MANUAL

99000-94310

FOREWORD

This manual contains an introductory description on HYOSUNG 『*www*』 and procedures for its inspection /service and overhaul of its main components. Other information considered as generally known is not included.

Read GENERAL INFORMATION section to familiarize yourself with outline of the vehicle and MAINTENANCE and other sections to use as a guide for proper inspection and service.

This manual will help you know the vehicle better so that you can assure your customers of your optimum and quick service.

- ❖ This manual has been prepared on the basis of the latest specification at the time of publication. If modification has been made since then, difference may exist between the content of this manual and the actual vehicle.
- ❖ Illustrations in this manual are used to show the basic principles of operation and work procedures. They may not represent the actual vehicle exactly in detail.
- ❖ This manual is intended for those who have enough knowledge and skills for servicing HYOSUNG vehicles. Without such knowledge and skills, you should not attempt servicing by relying on this manual only. Instead, please contact your nearby authorized HYOSUNG motorcycle dealer.

GROUP INDEX

GENERAL INFORMATION

1

PERIODIC MAINTENANCE

2

ENGINE

3

FUEL SYSTEM

4

ELECTRICAL SYSTEM

5

CHASSIS

6

SERVICING INFORMATION

7



HYOSUNG MOTORS & MACHINERY INC.

Overseas Technical Department

HOW TO USE THIS MANUAL





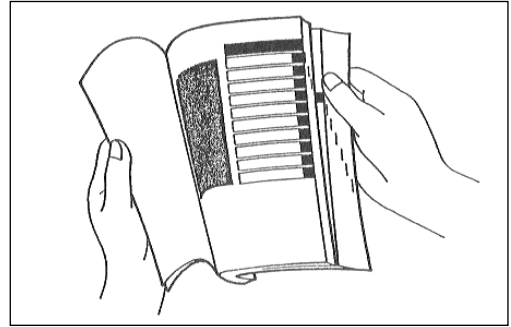







TO LOCATE WHAT YOU ARE LOOKING FOR:

1. The text of this manual is divided into sections.
2. As the title of these sections are listed on the previous page as GROUP INDEX, select the section where you are looking for.
3. Holding the manual as shown at the right will allow you to find the first page of the section easily.
4. On the first page of each section, its contents are listed. Find the item and page you need.



SYMBOL

Listed in the table below are the symbols indicating instructions and other information necessary for servicing and meaning associated with them respectively.

SYMBOL	DEFINITION	SYMBOL	DEFINITION
	Torque control required. Data beside it indicates specified torque.		Apply THREAD LOCK "1324".
	Apply oil. Use engine oil unless otherwise specified.		Apply or use brake fluid.
	Apply SUPER GREASE "A".		Measure in voltage range.
	Apply SUPER GREASE "C".		Measure in resistance range.
	Apply SILICONE GREASE.		Measure in current range.
	Apply MOLY PASTE.		Use special tool.
	Apply BOND "1215".		

COMPONENT PARTS AND WORK TO BE DONE

Under the name of each system or unit, its exploded view is provided with work instruction and other service information such as the tightening torque, lubricating points and looking agent points.

Example : STEERING AND FRONT SUSPENSION

TIGHTENING TORQUE		
ITEM	N · m	kg · m
①	18 ~ 28	1.8 ~ 2.8
②	18.4 ~ 28.6	1.84 ~ 2.86
③	22.4 ~ 35.7	2.24 ~ 3.57
④	40 ~ 50	4.0 ~ 5.0
⑤	80 ~ 100	8.0 ~ 10.0
⑥	22 ~ 35	2.2 ~ 3.5
⑦	22 ~ 35	2.2 ~ 3.5
⑧	40 ~ 60	4.0 ~ 6.0

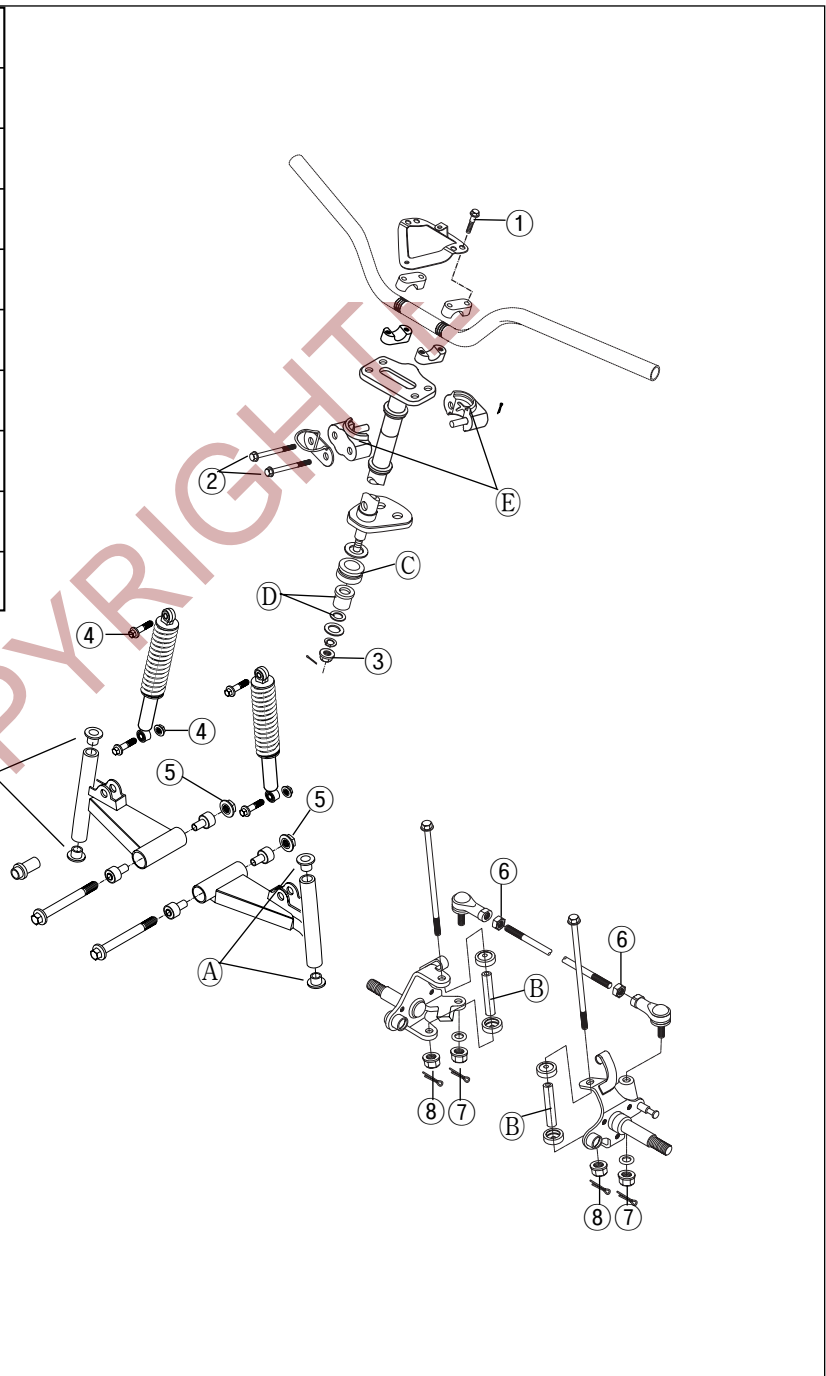

- Ⓐ : ASSEMBLING APPLY GREASE
- Ⓑ : ASSEMBLING APPLY GREASE
- Ⓒ : APPLY GREASE TO LIPS
- Ⓓ : APPLY GREASE
- Ⓔ : ASSEMBLING APPLY GREASE

COPYRIGHT

GENERAL INFORMATION

CONTENTS

INFORMATION LABELS	1-1
GENERAL PRECAUTIONS	1-1
SERIAL NUMBER LOCATION	1-4
FUEL AND OIL RECOMMENDATIONS	1-5
EXTERIOR ILLUSTRATION	1-6
SPECIFICATIONS	1-7

COPYRIGHT

WARNING / CAUTION / NOTE

Please read this manual and follow its instructions carefully. To emphasize special information, the symbol and the words WARNING, CAUTION and NOTE have special meanings. Pay special attention to the messages highlighted by these signal words.

WARNING

Indicates a potential hazard that could result in death or injury.

CAUTION

Indicates a potential hazard that could result in vehicle damage.

NOTE :

Indicates special information to make maintenance easier or instructions cleaner.

Please note, however, that the **WARNING** and **CAUTION** contained in this manual cannot possibly cover all potential hazards relating to the servicing, or lack of servicing, of the motorcycle. In addition to the **WARNING** and **CAUTION** stated, you must use good judgement and basic mechanical safety principles. If you are unsure about how to perform a particular service operation, ask a more experienced mechanic for advice.

GENERAL PRECAUTIONS

WARNING

- ❖ Proper service and repair procedures are important for the safety of the service machanic and the safety and reliability of the vehicle.
- ❖ When 2 or more persons work together, pay attention to the safety of each other.
- ❖ When it is necessary to run the engine indoors, make sure that exhaust gas is forced outdoors.
- ❖ When working with toxic or flammable materials, make sure that the area you work in is well-ventilated and that you follow all off the material manufacturer' s instructions.
- ❖ Never use gasoline as a cleaning solvent.
- ❖ To avoid getting burned, do not touch the engine, engine oil or exhaust system during or for a while after engine operation.
- ❖ After servicing fuel, oil, exhaust or brake systems, check all lines and fittings related to the system for leaks.

⚠ CAUTION

- ❖ If parts replacement is necessary, replace the parts with HYOSUNG Genuine Parts or their equivalent.
- ❖ When removing parts that are to be reused, keep them arranged in an orderly manner so that they may be reinstalled in the proper order and orientation.
- ❖ Be sure to use special tools when instructed.
- ❖ Make sure that all parts used in reassembly are clean, and also lubricated when specified.
- ❖ When use of a certain type of lubricant, bond, or sealant is specified, be sure to use the specified type.
- ❖ When removing the battery, disconnect the negative cable first and then positive cable. When reconnecting the battery, connect the positive cable first and then negative cable, and replace the terminal cover on the positive terminal.
- ❖ When performing service to electrical parts, if the service procedures do not require use of battery power, disconnect the negative cable at the battery.
- ❖ Tighten cylinder head and case bolts and nuts, beginning with larger diameter and ending with smaller diameter, from inside to outside diagonally, to the specified tightening torque.
- ❖ Whenever you remove oil seals, gaskets, packing, O-rings, locking washers, cotter pins, circlips, and certain other parts as specified, be sure to replace them with new ones. Also, before installing these new parts, be sure to remove any left over material from the mating surfaces.
- ❖ Never reuse a circlip. When installing a new circlip, take care not to expand the end gap larger than required to slip the circlip over the shaft. After installing a circlip, always ensure that it is completely seated in its groove and securely fitted.
- ❖ Do not use self-locking nuts a few times over.
- ❖ Use a torque wrench to tighten fasteners to the torque values when specified. Wipe off grease or oil if a thread is smeared with them.
- ❖ After reassembly, check parts for tightness and operation.

- ❖ To protect environment, do not unlawfully dispose of used motor oil and other fluids: batteries, and tires.
- ❖ To protect Earth's natural resources, properly dispose of used vehicles and parts.

HYOSUNG *now90*



NOTE :

Difference between photographs and actual vehicles depends on the markets.

SERIAL NUMBER LOCATION

The frame serial number or V.I.N. (Vehicle Identification Number) is stamped on the front frame member. The engine serial number is stamped on the right side of crankcase assembly.

These numbers are required especially for registering the machine and ordering spare parts.

● FRAME SERIAL NUMBER

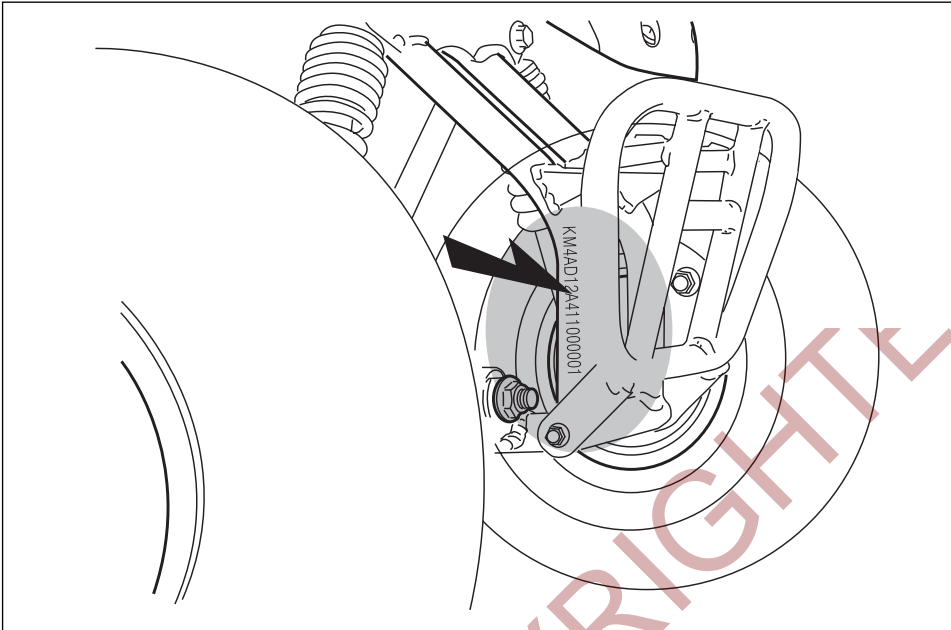

● ENGINE SERIAL NUMBER

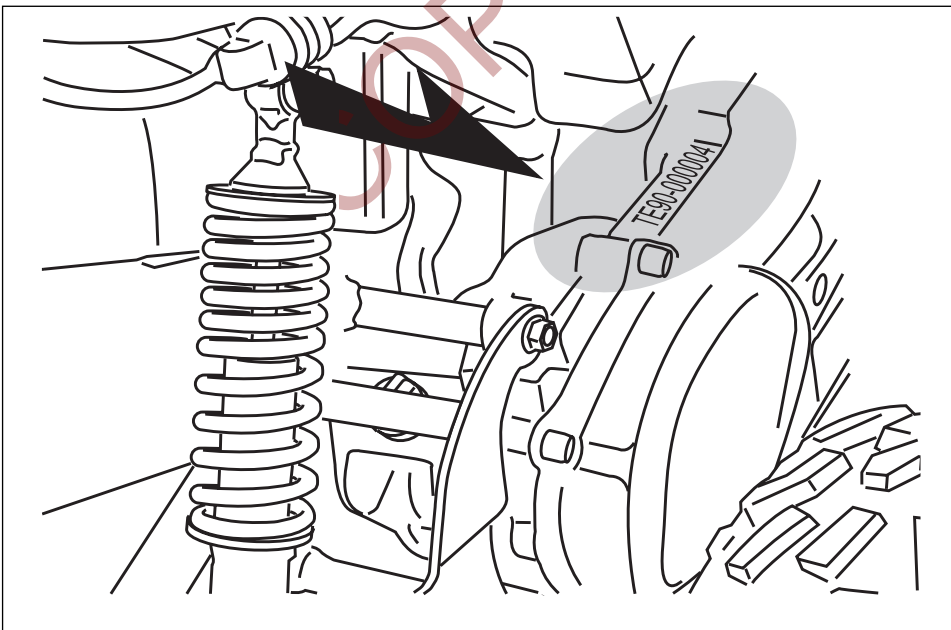

FUEL AND OIL RECOMMENDATIONS

⦿ FUEL

Gasoline used should be graded 85~95 octane or higher. An unleaded type gasoline is recommended. If engine pinging is experienced, substitute another brand as there are differences between brands.

⦿ ENGINE OIL

Use **HYOSUNG HYPOL OIL HS**.

If they are not available, use a good quality TWO-STROKE engine oil.

⦿ TRANSMISSION OIL

Use a good quality SAE 10W/30 or 10W/40 multigrade motor oil.

Classification system	Grade
API	SF or SG
SAE	10W/30 or 10W/40

❖ *If an SAE 10W/40 motor oil is not available, select an alternative according to the following chart.*

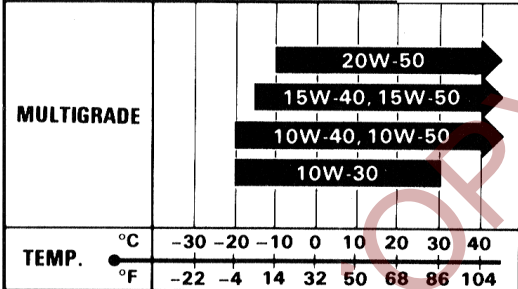

EXTERIOR ILLUSTRATION

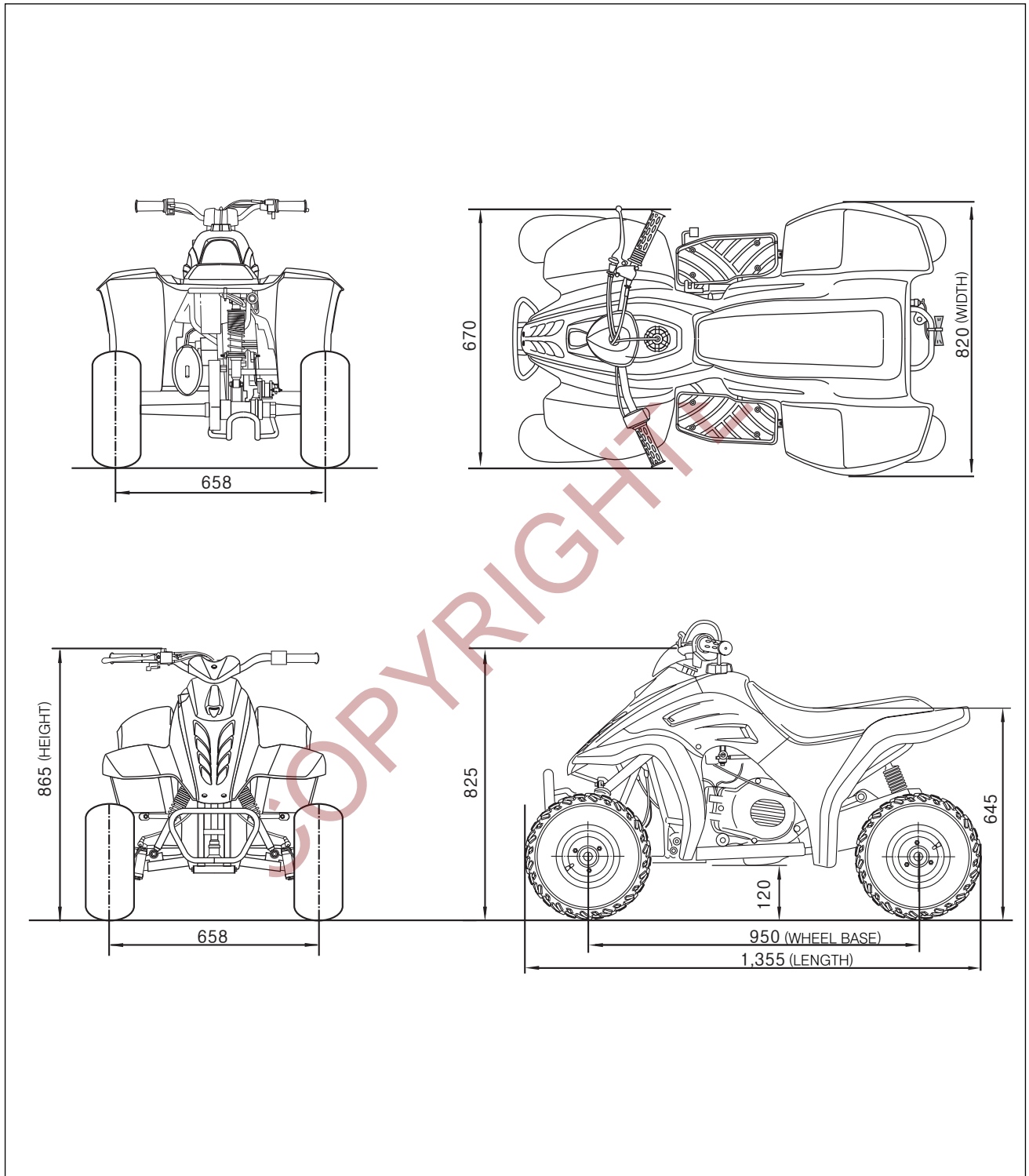

SPECIFICATIONS

DIMENSIONS AND DRY MASS

Overall length	1,355 mm (53.4 in)
Overall width	820 mm (32.3 in)
Overall height	865 mm (34.1 in)
Wheelbase	950 mm (37.4 in)
Ground clearance	120 mm (4.7 in)
Front track	658 mm (25.9 in)
Rear track	658 mm (25.9 in)
Mass	95 kg (209.5 lbs)

ENGINE

Type	Two-stroke, forced air cooled
Intake system	Reed valve
Number of cylinder	1
Bore x Stroke	52.5 mm (2.07 in) × 41.4 mm (1.63 in)
Piston displacement	89 cm ³ (5.43 in ³)
Corrected compression ratio	6.6 : 1
Carburetor	PB11M
Air cleaner	Polyurethane foam element

TRANSMISSION

Clutch	Dry shoe, automatic, centrifugal type
Transmission	2.842 ~ 1.042
Drive system	428H 56 links

CHASSIS

Steering angle	37.5° (right & left)
Trail	15 mm (0.591 in)
Turning radius	2,595 mm (102.17 in)
Toe-in	8 mm (0.315 in)
Camber angle	1°
Caster angle	5°
Front brake	Drum
Rear brake	Disk
Front tire size	18 × 7.00 - 7
Rear tire size	18 × 7.00 - 7

ELECTRICAL

Ignition type	"CDI" Type
Ignition timing	8° B.T.D.C at 1,000 rpm and 20° B.T.D.C at 4,000rpm
Spark plug	BPR7HS

CAPACITIES

Fuel tank	4 l
Engine oil tank	1 l
Transmission oil	80 ml (Replace)
	90 ml (Overhaul)

NOTE :

These specifications are subject to change without notice.

PERIODIC MAINTENANCE

CONTENTS

PERIODIC MAINTENANCE SCHEDULE	2- 1
PERIODIC MAINTENANCE CHART	2- 1
LUBRICATION POINTS	2- 2
MAINTENANCE PROCEDURES	2- 3
AIR CLEANER	2- 3
CYLINDER HEAD NUTS	2- 4
CYLINDER HEAD AND CYLINDER	2- 4
SPARK PLUG	2- 5
CARBURETOR	2- 6
FUEL LINE	2- 6
TRANSMISSION OIL	2- 7
BRAKES	2- 7
DRIVE CHAIN	2-10
TIRE	2-11
STEERING	2-12
CHASSIS BOLTS AND NUTS	2-12

2-1 PERIODIC MAINTENANCE

PERIODIC MAINTENANCE SCHEDULE

The chart below lists the recommended intervals for all the required periodic service work necessary to keep the vehicle operating at peak performance and economy.

⚠ CAUTION

More frequent servicing should be performed on vehicles that are used under severe conditions.

PERIODIC MAINTENANCE CHART

⊙ ENGINE

Item \ Interval	Initial 1 month	Every 3 months	Every 6 months	page
Air cleaner element	Clean at least every month			2 - 3
Cylinder head nuts	Tighten	Tighten	—	2 - 4
Cylinder head and cylinder	—	—	Remove carbon	2 - 4
Carburetor	Inspect	—	Inspect	2 - 6
Spark plug	Clean	Clean	Replace	2 - 5
Fuel line	Inspect	Inspect	—	2 - 6
	Replace every 4 years			
Transmission oil	Inspect	—	Inspect	2 - 7
Drive chain	Inspect and lubricate every month			2 - 10
Sprockets	Inspect	Inspect	—	6 - 17

⊙ CHASSIS

Item \ Interval	Initial 1 month	Every 3 months	Every 6 months	page
Brakes	Inspect	Inspect	—	2 - 7
Steering	Inspect	Inspect	—	2 - 12
Tire	Inspect every month · Check pressure each time ride.			2 - 11
Chassis bolts and nuts	Tighten	Tighten	—	2 - 12
General lubrication	—	Lubricate	—	2 - 2

LUBRICATION POINTS

Proper lubrication is important for smooth operation and long life of each working part of the vehicle. Major lubrication points are indicated below.

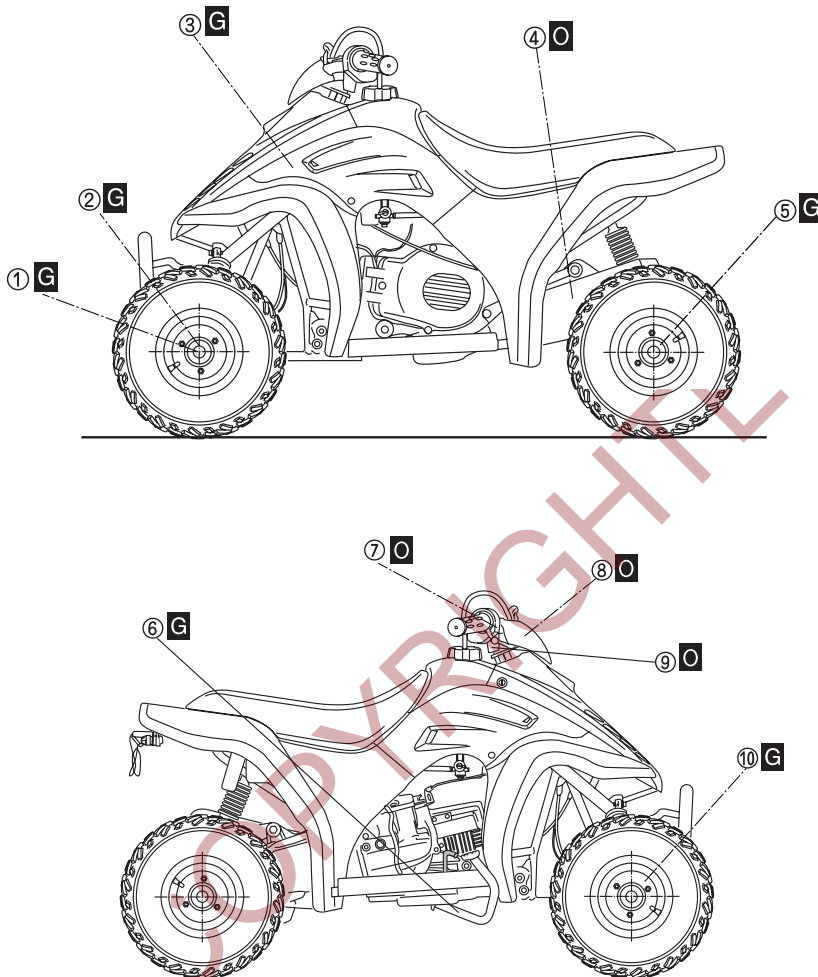

- ① King pin
- ② Front wheel bearing
- ③ Steering shaft holder
- ④ Drive chain
- ⑤ Rear axle housing
- ⑥ Rear brake cable

- ⑦ Front brake cable
- ⑧ Throttle cable
- ⑨ Throttle lever
- ⑩ Front brake cam shaft

O - Motor oil, **G** - Grease

NOTE :

- ❖ Before lubricating each part, clean off any rusty spots and wipe off any grease, oil, dirt or grime.
- ❖ Lubricate exposed parts which are subject to rust, with either motor oil or grease whenever the vehicle has been operated under wet or rainy condition.

MAINTENANCE PROCEDURES

AIR CLEANER

NOTE :

Clean at least Every month.

If the air cleaner is clogged with dust, intake resistance will increased with a resultant decrease in output and an increase in fuel consumption. Check and clean the element in the following manner.

- Stand the vehicle in the standing position.
- Remove the four bolts ①.
- Remove the clamp screw ②.
- Remove the air cleaner case ⑤.
- Remove the element ④ from the cap ③.
- Fill a washing pan of a proper size with nonflammable cleaning solvent. Immerse the element in the cleaning solvent and wash it clean.
- Squeeze the cleaning solvent out of the washed element by pressing it between the palms of both hands : do not twist or wring the element or it will develop tears.
- Immerse the element in HYOSUNG genuine oil and squeeze the oil out of the element leaving it slightly wet with oil.
- Fit the cleaner element to frame properly.

⚠ CAUTION

- ❖ Before and during the cleaning operation, inspect the element for tears. A torn element must be replaced.
- ❖ Be sure to position the element snugly and correctly, so that no incoming air will bypass it. Remember, rapid wear of piston rings and cylinder bore is often caused by a defective or poorly fitted element.

- Ⓐ Non-flammable cleaning solvent
- Ⓑ 2-stroke engine oil.

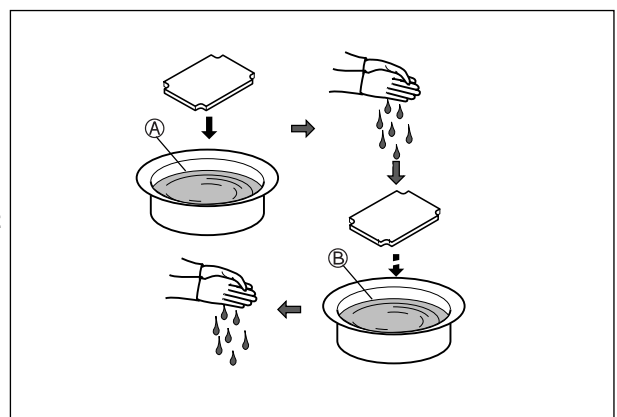
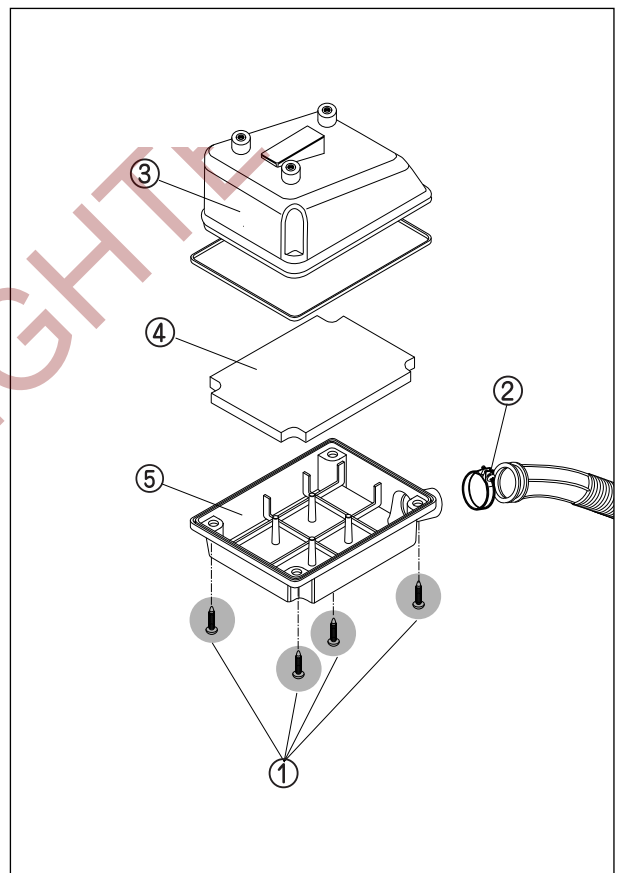
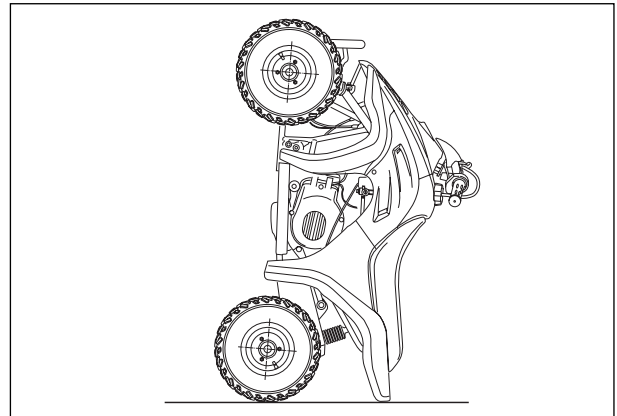

CYLINDER HEAD NUTS

NOTE :

Tighten Initial 1 month and Every 3 months.

Cylinder head nuts, when they are not tightened to the specified torque, may result in leakage of the compressed mixture and reduce output.

First loosen the nuts and tighten the 4 nuts evenly one by one in stages until each one is tightened to the specified torque. Tighten the nuts in the order indicated.

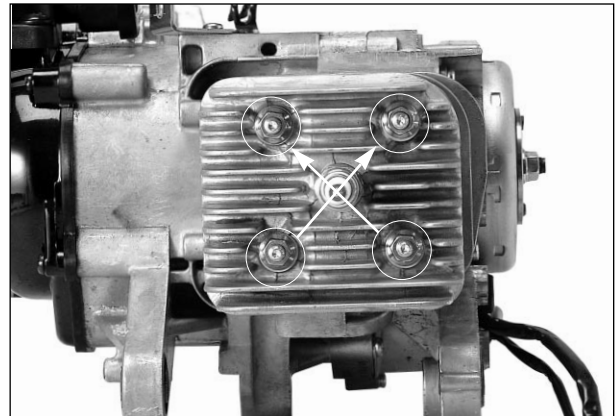

 Cylinder head nut : 18~28 N · m (1.8~2.8 kg · m)

CYLINDER HEAD AND CYLINDER

NOTE :

Remove carbon Every 6 months.

Carbon deposits in the combustion chamber and the cylinder head will raise the compression ratio and may cause pre-ignition or overheating. Carbon deposited at the exhaust port of the cylinder will prevent the flow of exhaust gases, reducing the output. Remove carbon deposits periodically.

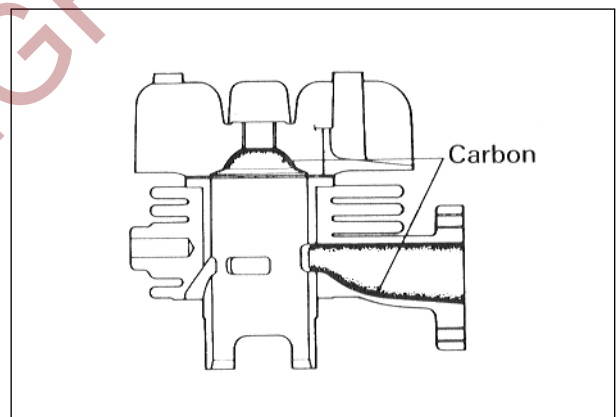

2-5 PERIODIC MAINTENANCE

SPARK PLUG

NOTE :

**Inspect Initial 1 month and Every 3 months,
Replace Every 6 months.**

Neglecting the spark plug maintenance eventually leads to difficult starting and poor performance. If the spark plug is used for a long period, the electrode gradually burns away and carbon builds up along the inside part. In accordance with the Periodic Inspection Chart, the plug should be removed for inspection, cleaning and resetting the gap.

- Carbon deposits on the spark plug will prevent good sparking and cause misfiring. Clean the deposits off periodically.
- If the center electrode is fairly worn down, the plug should be replaced and the plug gap set to the specified gap using a thickness gauge.

Spark plug gap

0.6~0.7 mm
(0.024~0.028 in)



Thickness gauge : 09900-20804

- Check spark plug for burnt condition. If abnormal, replace the plug as indicated below.

TYPE	SPARK PLUG SPECIFICATION
Hot type	BPR6HS
Standard type	BPR7HS
Cold type	BPR8HS



Spark plug : 25~30 N · m (2.5~3.0 kg · m)



CAUTION

- To check the spark plug, first make sure that the fuel used is unleaded gasoline, and if plug is either sooty with carbon or burnt white, replace it.
- Confirm the thread size and reach when replacing the plug.

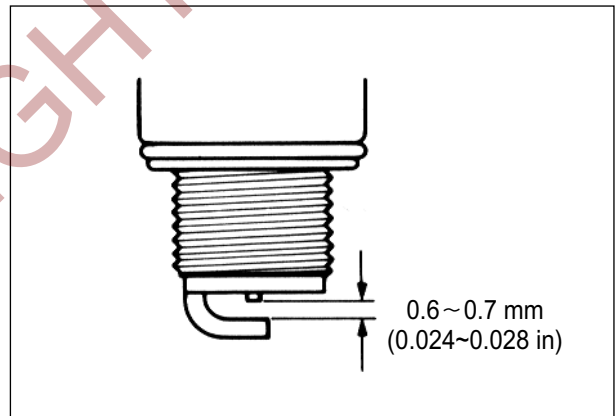
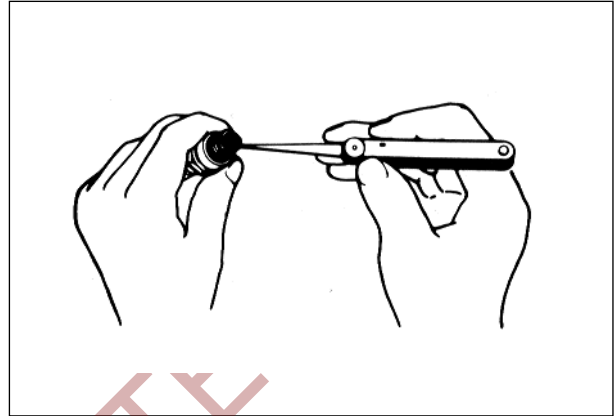

CARBURETOR

NOTE :

Inspect Initial 1 month and Every 6 months.

⊙ **IDLE SPEED**

- Adjust the throttle cable play.
- Warm the engine up.

NOTE :

A warm engine means an engine has been run for 10 minutes.

- Remove the seat and cover.
- Adjust the throttle stop screw ① to obtain the idle speed as follows.

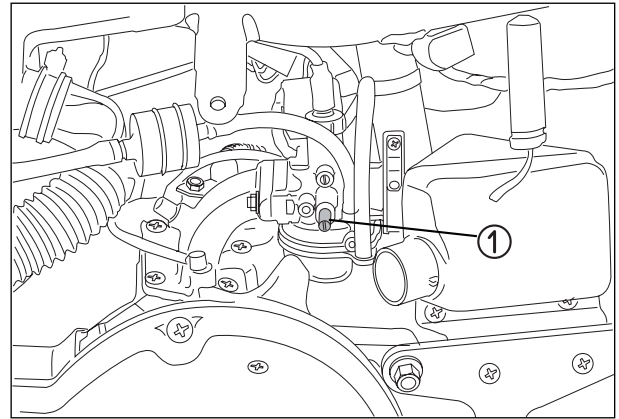

Engine idle speed	1,800 ± 100 rpm
--------------------------	-----------------

 **Engine tachometer : 09900-26006**

- Finally adjust the throttle cable play.

⊙ **THROTTLE CABLE PLAY**

- Loosen the lock nut ② and adjust the cable slack by turning adjuster ③ in or out to obtain the following cable play.
After adjusting play, tighten the lock nut.

Throttle cable slack	0.5 ~ 1.0 mm (0.020 ~ 0.039 in)
-----------------------------	------------------------------------

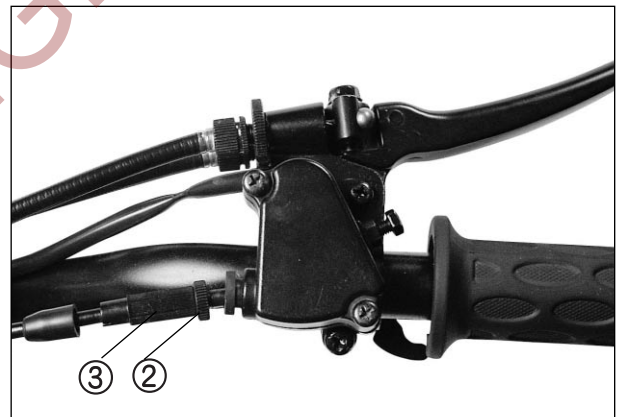

FUEL LINE

NOTE :

*Inspect Initial 1 month and Every 3 months,
Replace every 4 years.*

Inspect leakage of the fuel line and connection part.
If abnormal, replace it.

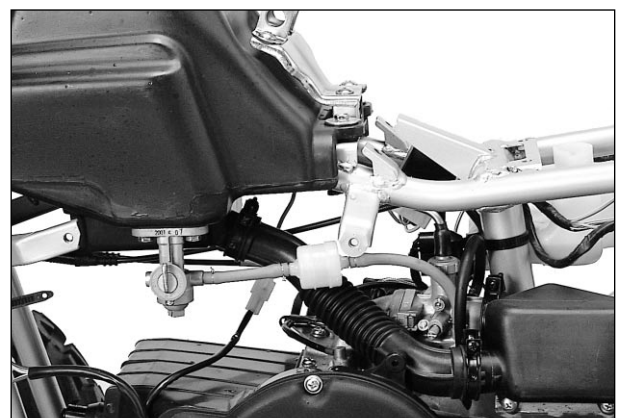

TRANSMISSION OIL

NOTE :

Inspect Initial 1 month and Every 6 months.

After a long period of use, the transmission oil qualities will deteriorate and quicken the wear of sliding and interlocking surfaces. Replace the transmission oil periodically following the procedure below.

- Start the engine to warm up the oil, this will facilitate draining of oil.
- Unscrew the oil filler cap ① and drain plug ②, and drain the oil completely.
- Tighten the drain plug.
- Supply a good quality SAE 10W/30 or 10W/40 multi-grade motor oil.

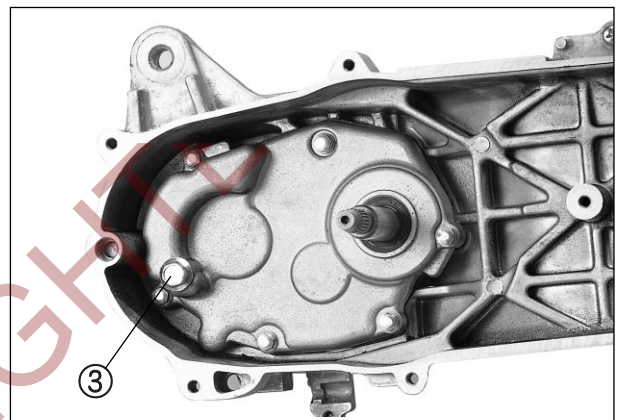
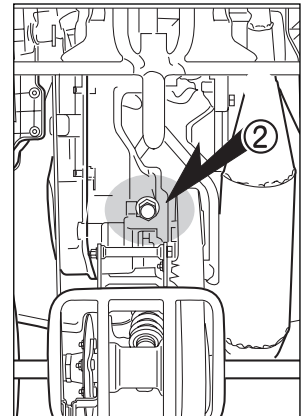
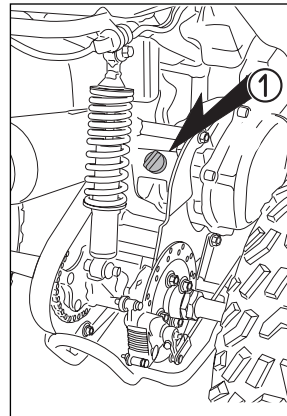

TRANSMISSION OIL CAPACITY	
Change	80 ml
Overhaul	90 ml

- Check the oil level with the oil level screw ③ .

BRAKES

NOTE :

Inspect Initial 1 month and Every 3 months.

○ **FRONT BRAKE**

■ **BRAKE ADJUSTMENT**

Adjust the free play ④ to 5 ~ 15mm (0.197 ~ 0.591 in) by screwing in or out the front brake adjust nut ⑤.

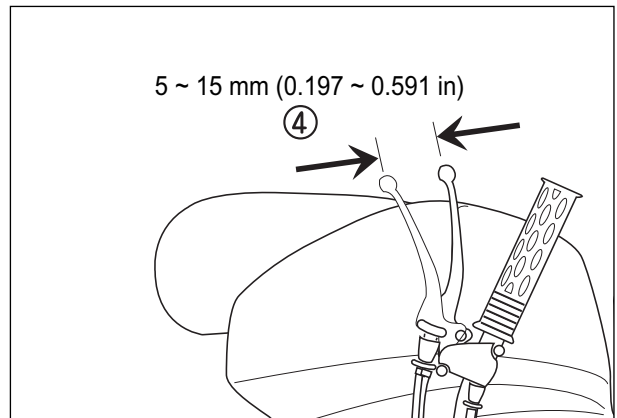

Front brake lever play	5 ~ 15 mm (0.197 ~ 0.591 in)
------------------------	---------------------------------

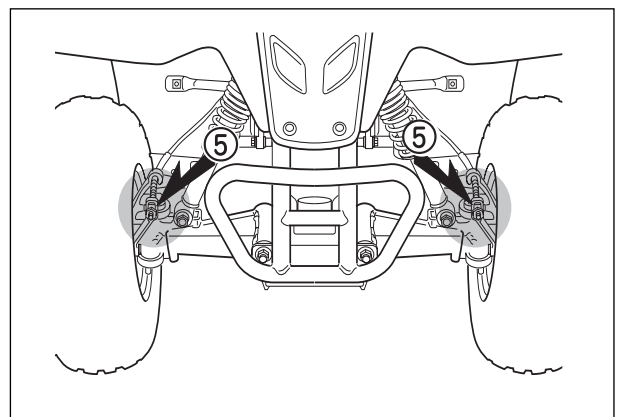

■ BRAKE LINING WEAR LIMIT

This vehicle is equipped with the brake lining wear limit indicator on the front brake. As shown in the illustration at right, at the condition of normal lining wear, an extended line from the index mark on the brake camshaft should be within the range embossed on the brake panel. To check wear of the brake lining, follow the steps below.

- First check if the brake system is properly adjusted.
- While operating the brake, check to see that the extension line from the index mark is within the range on the brake panel.
- If the index mark is outside the range as shown in the illustration at right, the brake shoe assembly should be replaced to ensure safe operation.

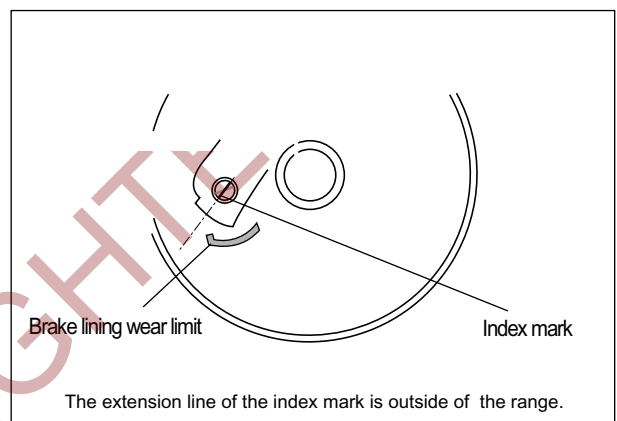
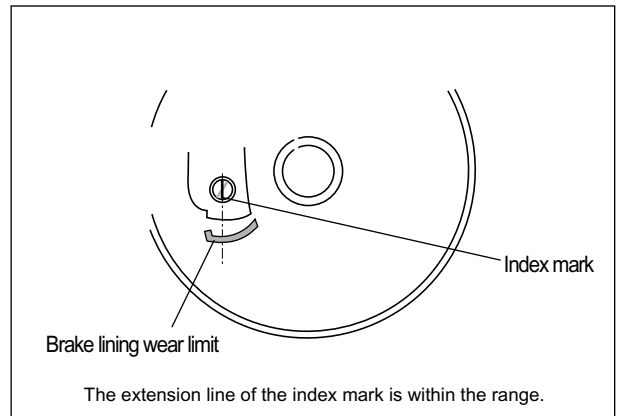

○ **REAR BRAKE**

■ BRAKE ADJUSTMENT

Set the parking brake by pulling the lock lever ①. Rock the vehicle by pushing to see if the brake is sufficiently holding the wheels locked. Adjust the brake, if necessary, by turning the adjuster ② in or out.

Rear brake pedal play ③	15 ~ 25 mm (0.591 ~ 0.984 in)
--------------------------------	----------------------------------

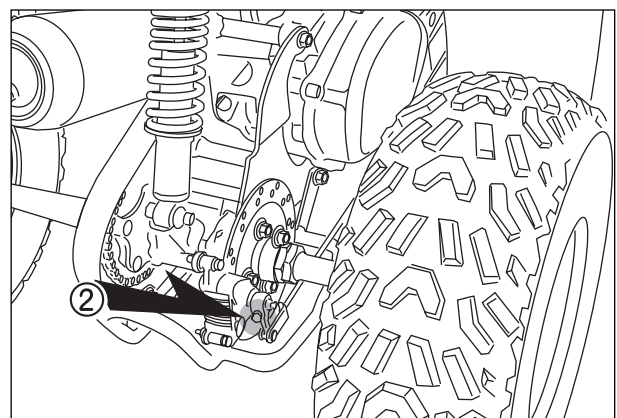
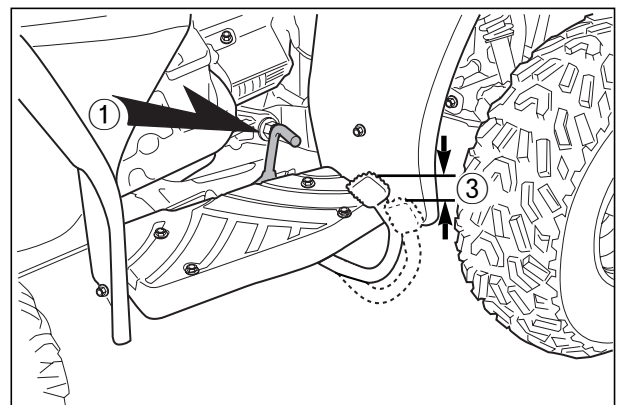

2-9 PERIODIC MAINTENANCE

■ BRAKE PAD WEAR

The extent of brake pad wear can be checked by observing the grooved limit $\text{\textcircled{A}}$ on the pad. When the wear exceeds the grooved limit, replace the pads with new ones.

⚠ CAUTION

Replace the brake pad as a set, otherwise braking performance will be adversely affected.

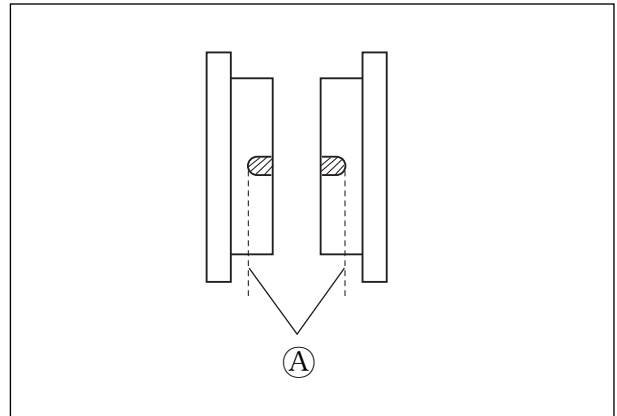

■ REAR BRAKE PAD REPLACEMENT

- Remove the brake caliper.
- Remove the brake pads.
- To reassemble, reverse the above sequence.

🔧 Rear brake caliper mounting bolt
: 5.0~7.0 N · m (0.5~0.7 kg · m)

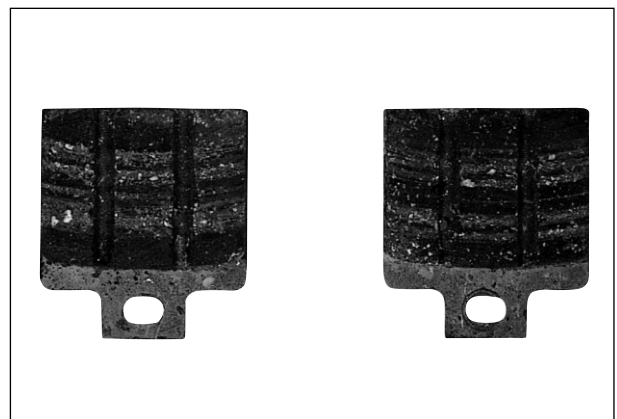
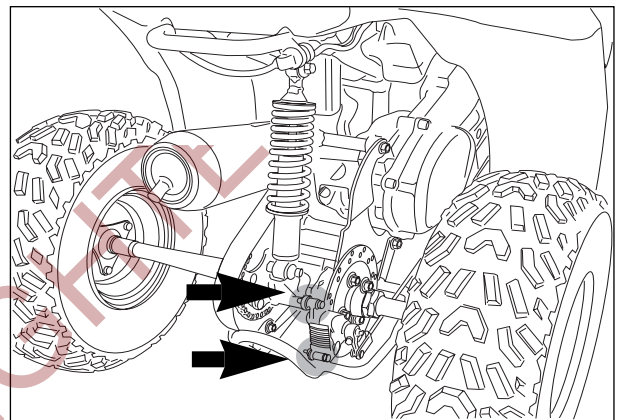

DRIVE CHAIN

NOTE :

Inspect and lubricate Every month.

Visually check the drive chain for the possible defects listed below.

1. Loosen pins
2. Damaged rollers
3. Dry or rusted links
4. Kinked or binding links
5. Excessive wear

If any defects are found, the drive chain must be replaced.

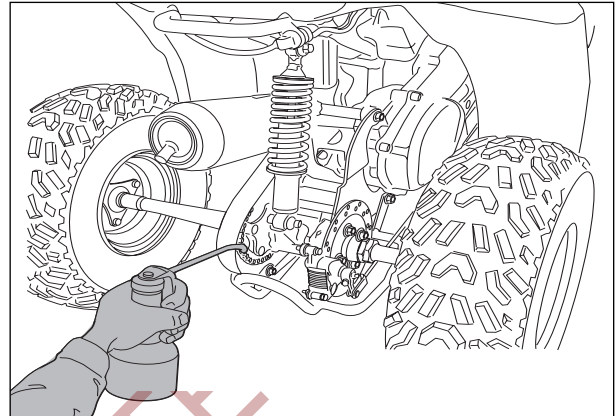

⊙ LUBRICATING THE DRIVE CHAIN

Dirt hastens wear of drive chain and sprockets. Lubricate the drive chain with chain lube or motor oil frequently. Every 1 month or more frequently, wash the chain clean in a pool of solvent and lubricate it with chain lube or motor oil. In a dusty area, this service should be given at shorter intervals.

⚠ CAUTION

When refitting the drive chain, be sure to install the chain joint clip as shown : the slit end faces counter to turning direction.

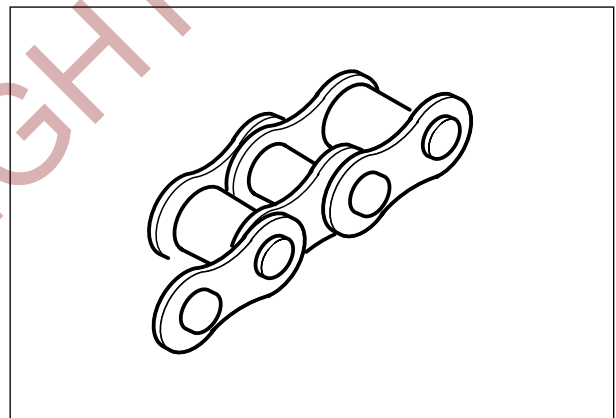

⊙ DRIVE CHAIN REPLACEMENT

The drive chain is checked when its slack (between two sprockets) is within 5~15 mm (0.197~0.591 in) range.

Drive chain slack

5 ~ 15 mm
(0.197 ~ 0.591 in)

If the drive chain slack exceeds the specification, the chain must be replaced.

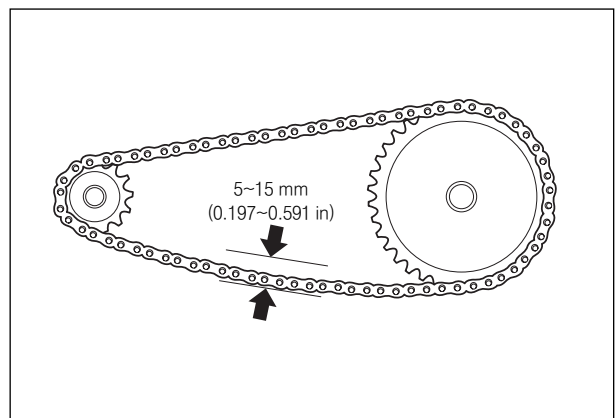

2-11 PERIODIC MAINTENANCE

TIRE

NOTE :

Inspect Every month. Check pressure each time ride.

⊙TIRE PRESSURE

If the tire pressure is too high, the vehicle will tend to ride stiffly, have poor traction. Conversely, if the tire pressure is too low, stability will be adversely affected. Therefore, maintain the correct tire pressure for good traction and prolonging tire life.

⚠ CAUTION

The standard tire fitted on this 「ATV」 is 18×7.00 - 7 for front and rear. The use of a tire other than the standard may cause handling instability. It is highly recommended to use a HYOSUNG Genuine Tire.

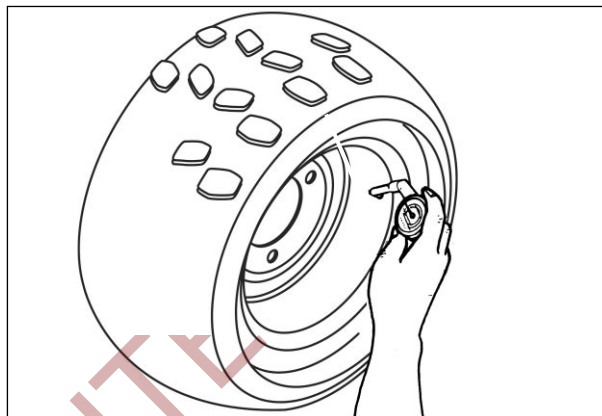

COLD INFLATION TIRE PRESSURE

	kPa	kgf/cm ²	psi
Front	25	0.25	3.6
Rear	25	0.25	3.6

⊙TIRE TREAD CONDITION

Operating the vehicle with excessively worn tires will decrease riding stability and consequently invite a dangerous situation. It is highly recommended to replace the tire when the remaining depth of tire tread reaches the following specifications.

Front and rear tire tread depth	Service limit
	10 mm (0.394 in)

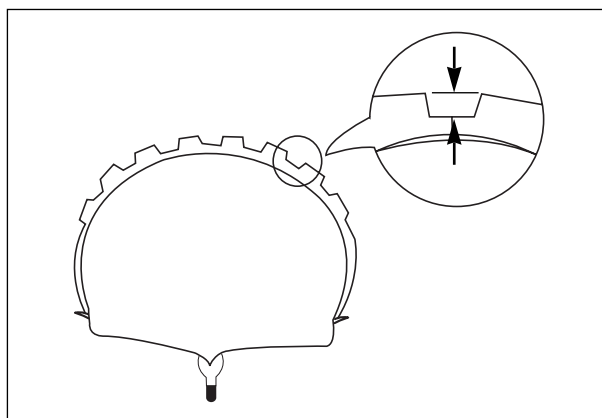

STEERING

NOTE :

Inspect Initial 1 month and Every 3 months.

Steering system should be adjusted properly for smooth manipulation of handlebars and safe running.

⦿ **TOE-IN**

- Place the vehicle on the level ground.
- Make sure that the tire pressure is within specification. (Refer to page 2-11)



- The front wheels are set in straight-ahead position.
- Measure the distance (A and B in illustration) of front wheels with a gauge as shown in illustration and calculate the difference between A and B.

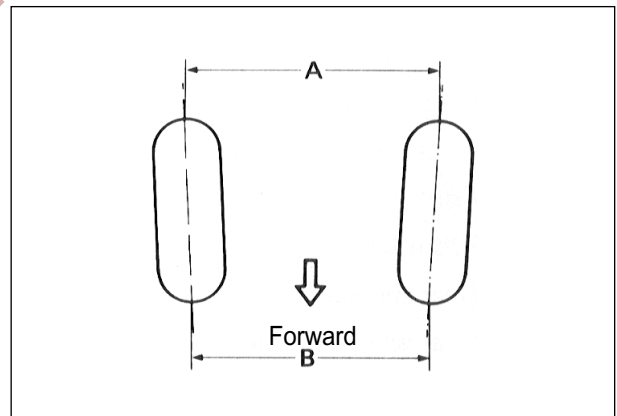

Toe - in	8.0 mm (0.315 in)
-----------------	----------------------

- If the toe-in is off the specification, bring it into the specified range. (Refer to page 6-11)

CHASSIS BOLTS AND NUTS

NOTE :

Tighten Initial 1 month and Every 3 months.

Check that all chassis bolts and nuts are tightened to their specified torque. (Refer to page 7-9)

COPYRIGHT

ENGINE

CONTENTS

ENGINE REMOVAL AND REINSTALLATION	3- 1
ENGINE REMOVAL	3- 1
ENGINE REINSTALLATION	3- 5
ENGINE DISASSEMBLY	3- 6
ENGINE COMPONENTS INSPECTION AND SERVICING	3-16
BEARINGS	3-16
OIL SEALS	3-16
CRANKSHAFT	3-16
AUTOMATIC CLUTCH INSPECTION	3-17
CYLINDER HEAD	3-20
CYLINDER	3-21
PISTON	3-21
REED VALVE	3-24
ENGINE REASSEMBLY	3-24
OIL SEALS	3-24
BEARINGS	3-25
BUSHINGS	3-25
CRANKSHAFT	3-26
CRANKCASE	3-27
TRANSMISSION	3-28
STARTER PINION, STARTER DRIVEN GEAR AND	
STARTER MOTOR	3-30
MOVABLE DRIVEN AND CLUTCH	3-32
MOVABLE DRIVE	3-36
MAGNETO	3-38
PISTON	3-39
OIL PUMP AND INTAKE PIPE	3-41
COOLING FAN	3-42
MUFFLER	3-43

ENGINE REMOVAL AND REINSTALLATION

ENGINE REMOVAL

Before taking the engine out of the frame, thoroughly clean the engine with a suitable cleaner and drain transmission oil, etc. The procedure of engine removal is sequentially explained in the following steps, and engine reinstallation is effected by reversing the removal procedure.

- Place an oil pan under the engine and remove the oil filler cap and the oil drain plug to drain out transmission oil.
- Remove the seat and frame cover.
- Turn the fuel cock to "OFF" position.

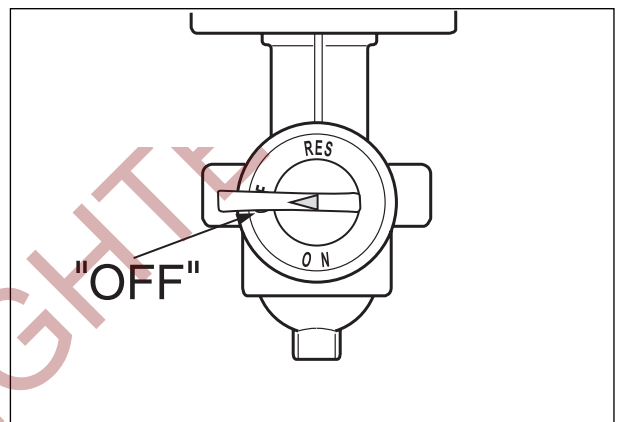
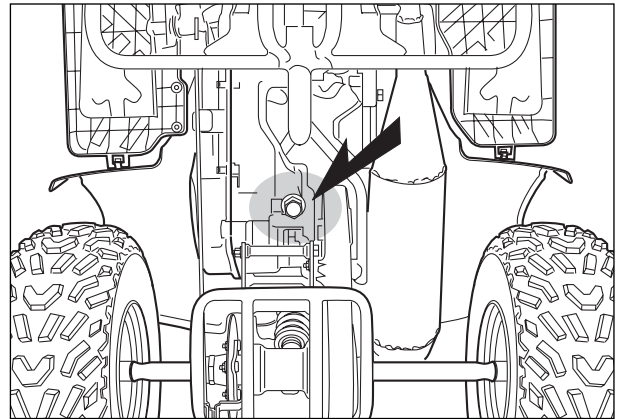

- Remove the fuel hoses from the fuel cock and remove the fuel tank by removing mounting bolts.



- Remove the muffler and exhaust pipe.

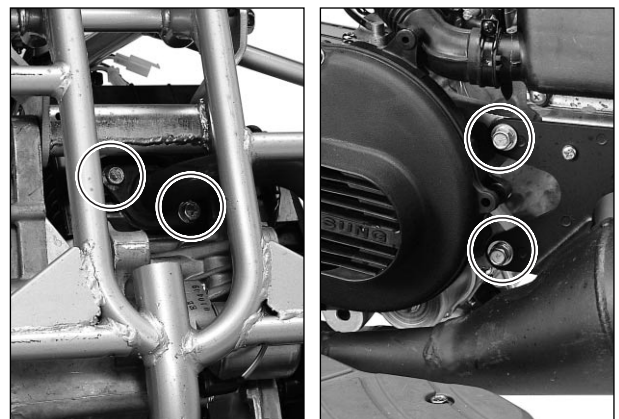

- Remove the engine ground lead wire ①.

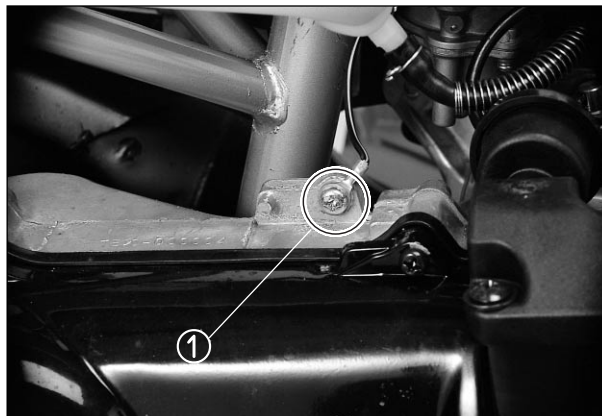

- Remove the spark plug cap ②.



- Remove the starter motor lead wire ③.



- Disconnect the magneto coil lead wire ④.



3-3 ENGINE

- Disconnect the thermoelement coupler ①.

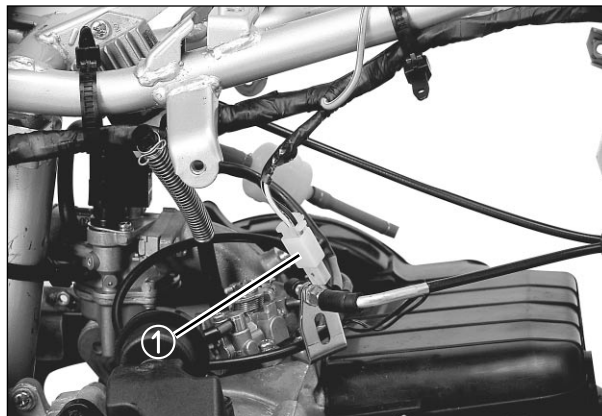

- Remove the air cleaner ② and air cleaner chamber ③.

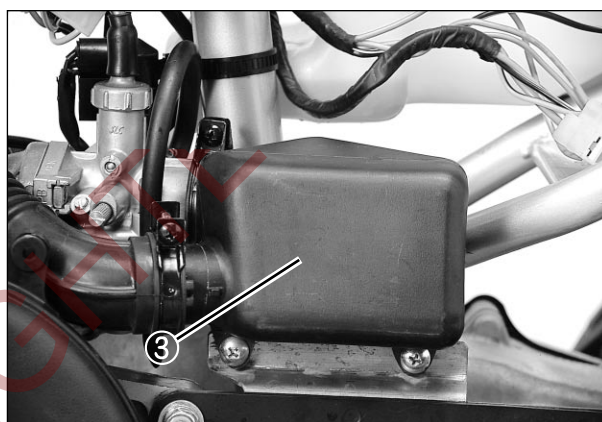
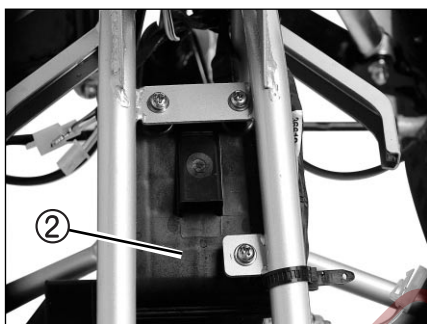

- Remove the carburetor assembly from the intakepipe.



- Disconnect the oil hose and oil pump cable from the oil pump.



- Remove the chain case cover.
- Remove the engine sprocket from the drive shaft by using the snap ring pliers.
- Remove the drive chain.

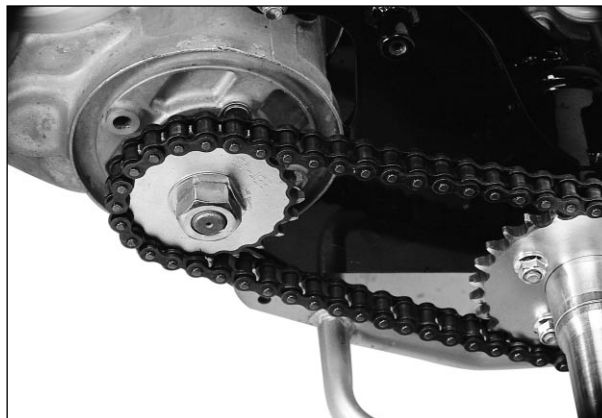

- Remove the seven engine mounting link bolts.
- Remove the engine assembly from the frame with rear axle housing assembly.

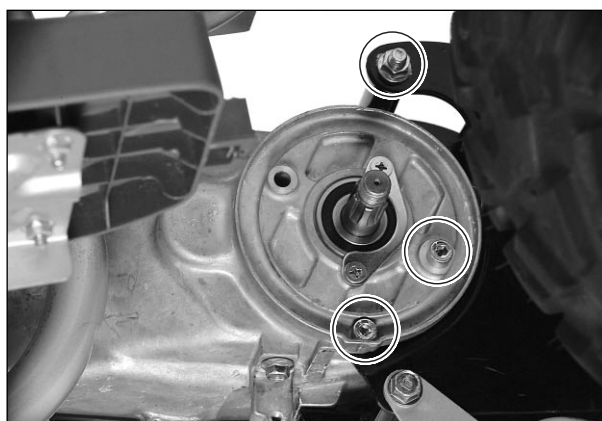
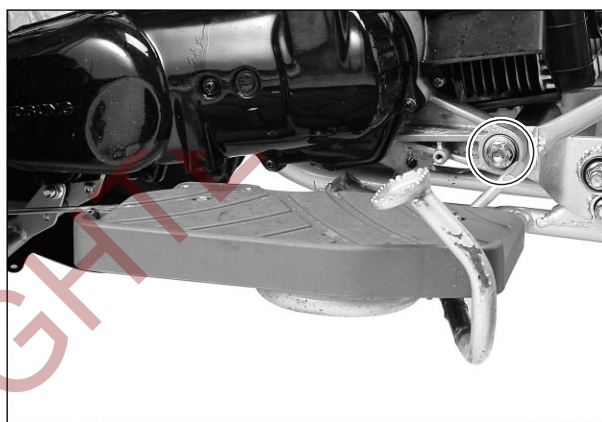

ENGINE REINSTALLATION

For remounting engine, reverse the order of engine removal and take the following additional steps.

- Install the engine mounting link bolts.
(Refer to page 3-4)

🔧 Engine mounting link bolt
: 70 ~ 100 N · m (7.0 ~ 10.0 kg · m)

- Install 90ml of transmission oil SAE 10W/30 or 10W/40 multi-grade motor oil when engine is overhauled, check the oil level.

Transmission oil capacity (when overhauling engine)	90 ml
--	--------------

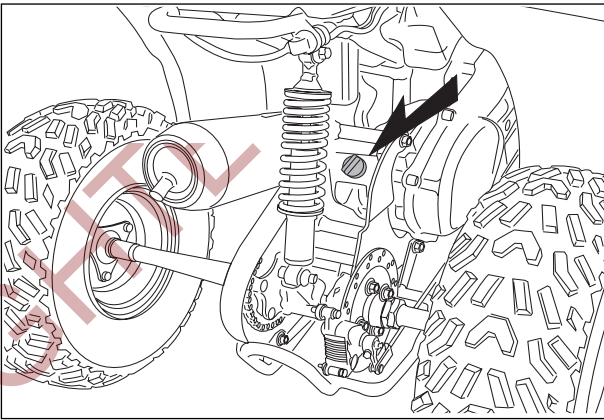

- Set the fuel cock to “ON” position and start the engine.

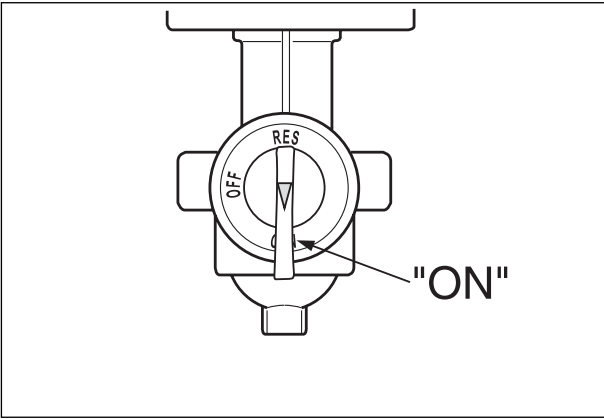

- After remounting the engine, route wiring harness and cables properly by referring to the sections, wire routing and cable routing, and adjust the following items to the specification.

- ❖ Throttle cable Refer to page 2- 6
- ❖ Idling adjustment Refer to page 2- 6
- ❖ Front brake cable Refer to page 2- 7
- ❖ Rear brake cable Refer to page 2- 8
- ❖ Drive chain Refer to page 2-10

ENGINE DISASSEMBLY

● MUFFLER

- Remove the muffler removing the bolts.

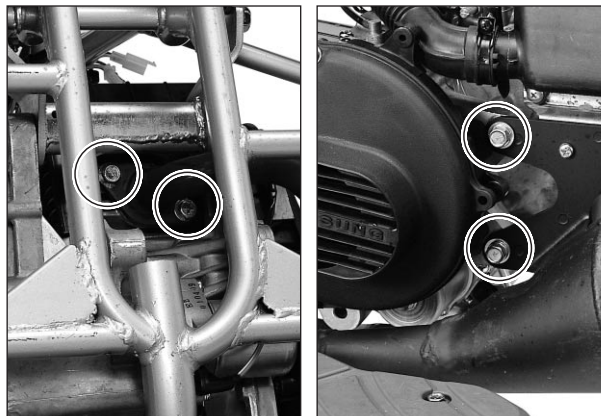

● CYLINDER

- Remove the cylinder cowling.
- Remove the cylinder head ① and cylinder ②.

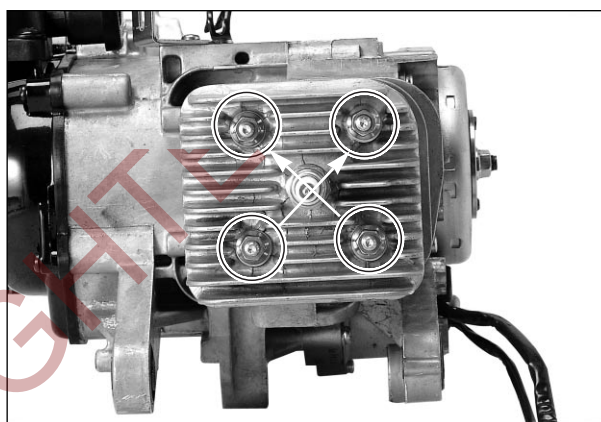
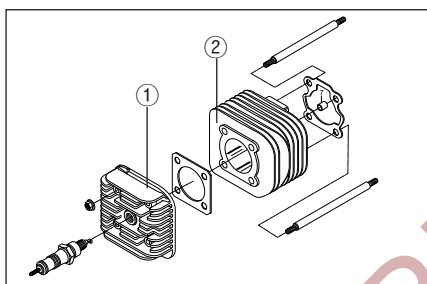

● PISTON

- Place a cloth beneath the piston and remove the piston pin circlip ③ with a long-nose pliers.
- Remove the piston pin ④ and piston ⑤.
- Remove the piston pin bearing ⑥.

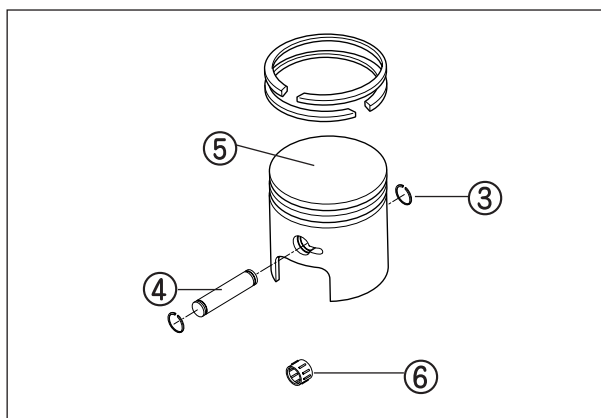
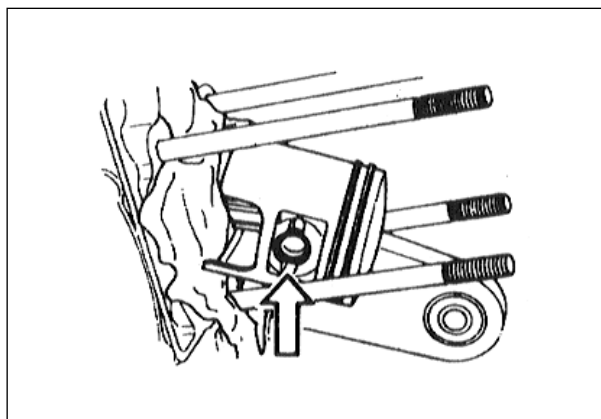

3-7 ENGINE

● INTAKE PIPE AND OIL PUMP

- Remove the intake pipe ① and oil pump ②.

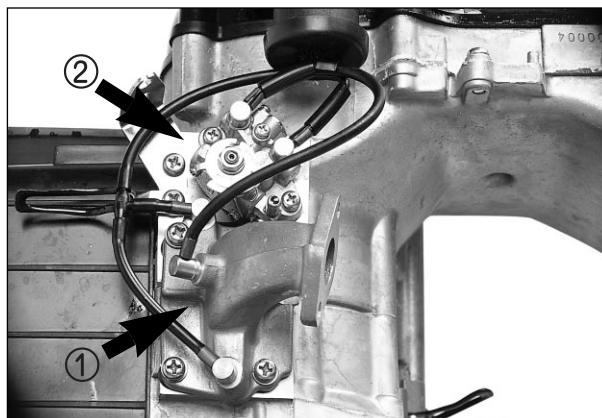
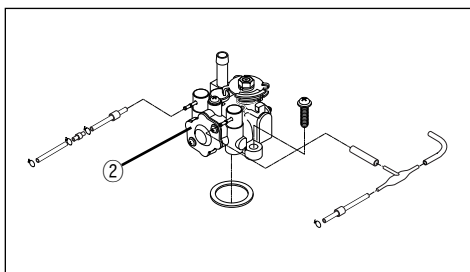

- Remove the reed valve ③.

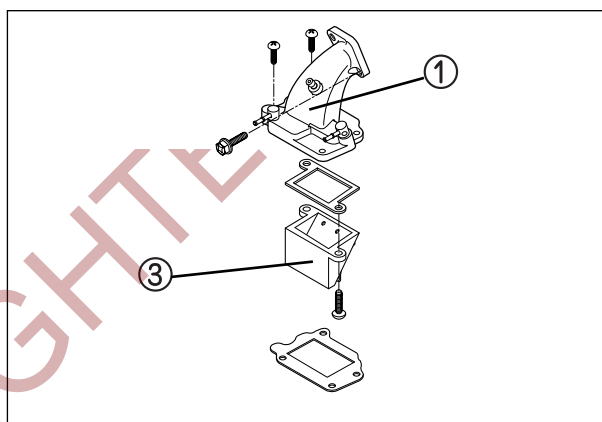

- Remove the oil pump driven gear ④.

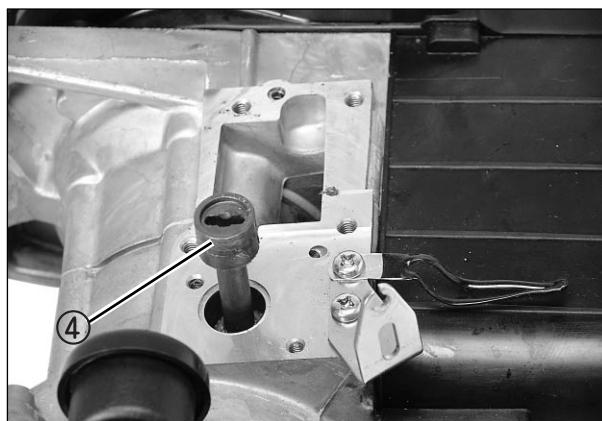
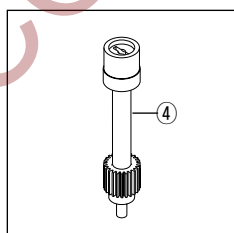

● MAGNETO

- Remove the cooling fan.
- Remove the magneto rotor nut with the special tool.

 Conrod holder : 09910-20115

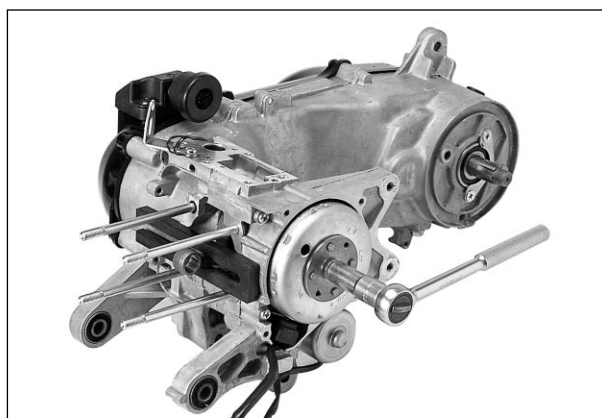

- Remove the magneto rotor with the special tool.

 **Rotor remover sliding shaft : 09930-30102**
Rotor remover : 09930-30163

- Remove the magneto stator and key.

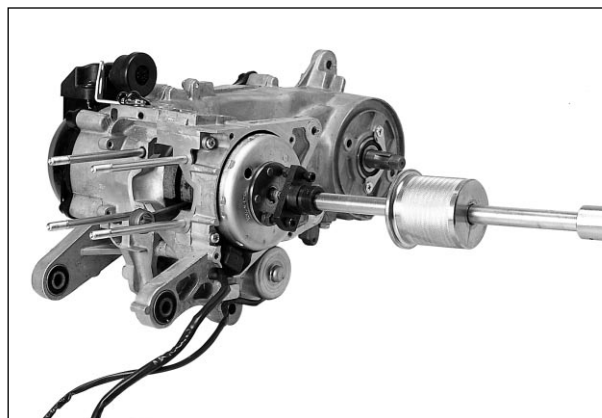

○ **MOVABLE DRIVE FACE**

- Remove the clutch cover.

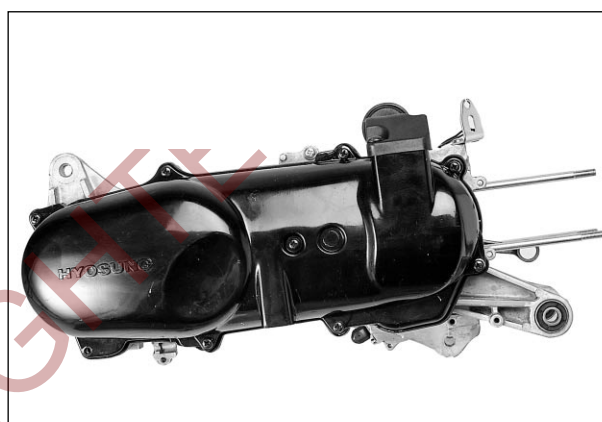

- Remove the fixed drive face nut ① with the special tool.

 **CAUTION**

This nut has left-hand thread.

 **Conrod holder : 09910-20115**

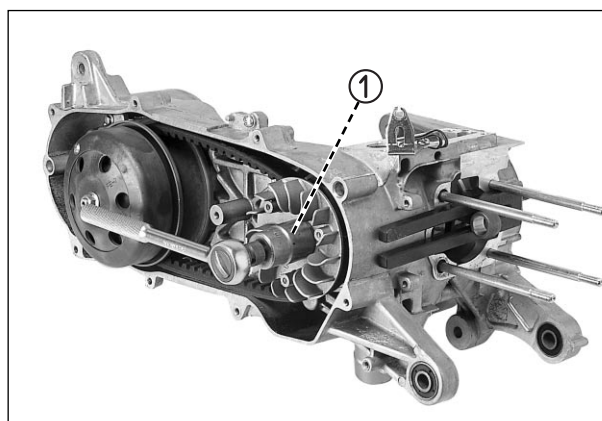

- Remove the fixed drive face ② and V-belt ③.
- Disassemble the movable drive face ④.

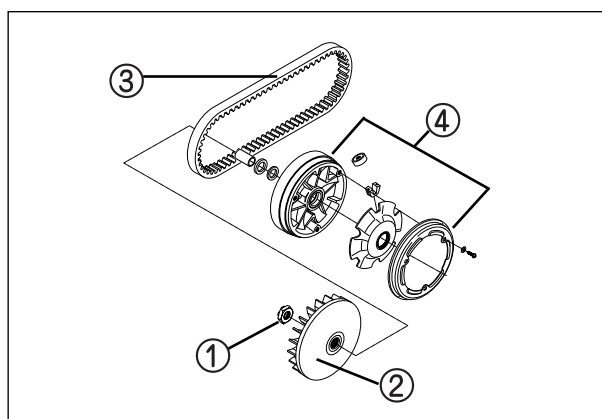

3-9 ENGINE

⊙ MOVABLE DRIVEN FACE

- Remove the clutch housing ①.

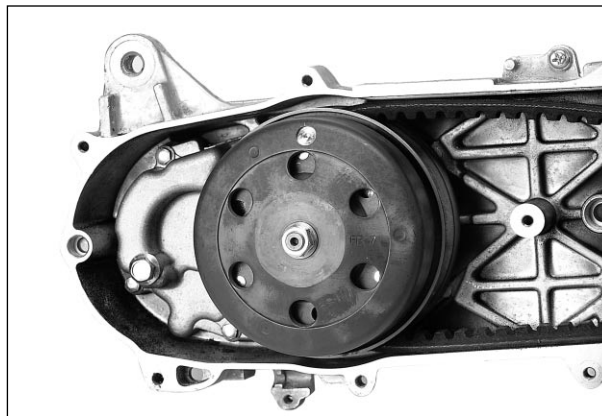
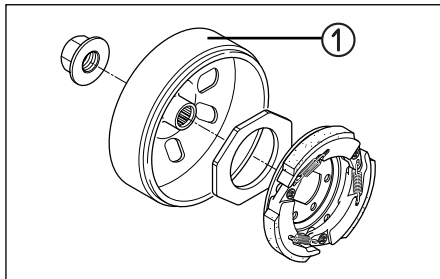

⊙ STARTER DRIVEN GEAR

- Remove the starter driven gear ②.

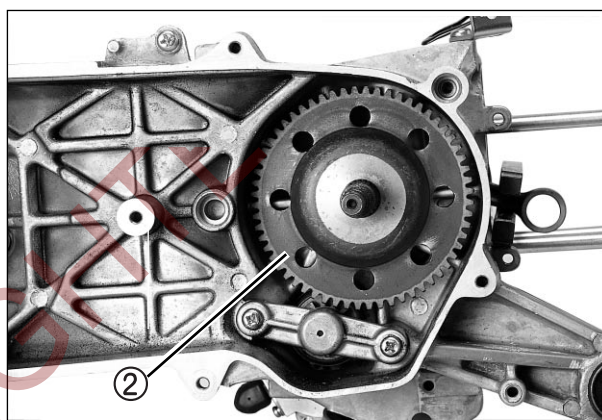

- Remove the starter idle gear cap and starter motor pinion.

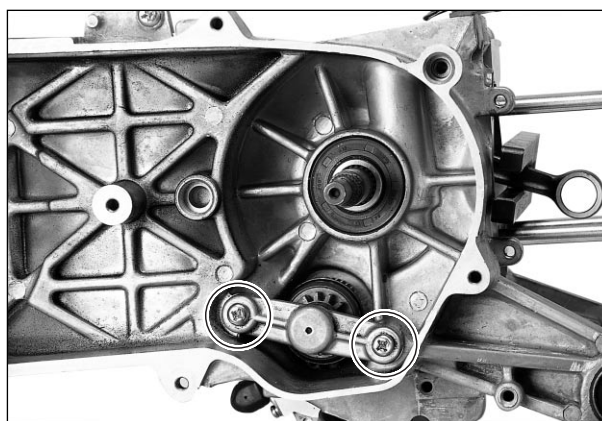

- Remove the starter motor.

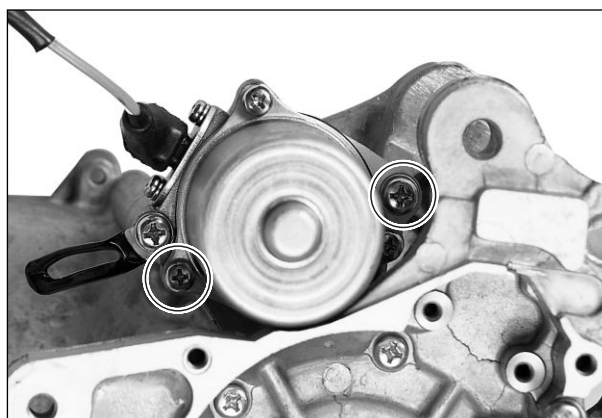

- Loosen the clutch shoe nut with the special tool.

 **Rotor holder : 09930-40113**

- Remove the nut while holding down the clutch shoe assembly by both hands as shown in the illustration.

⚠ WARNING

Gradually back off the clutch shoe assembly pressed down by hand to counter the clutch spring load. Releasing the hand suddenly may cause the parts to fly apart.

- ① Nut
- ② Clutch shoe assembly
- ③ Spring

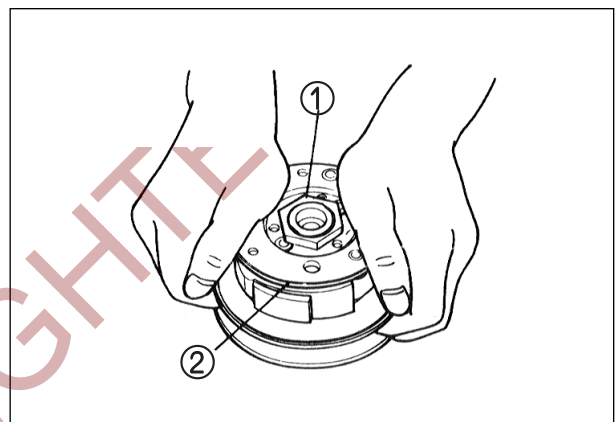
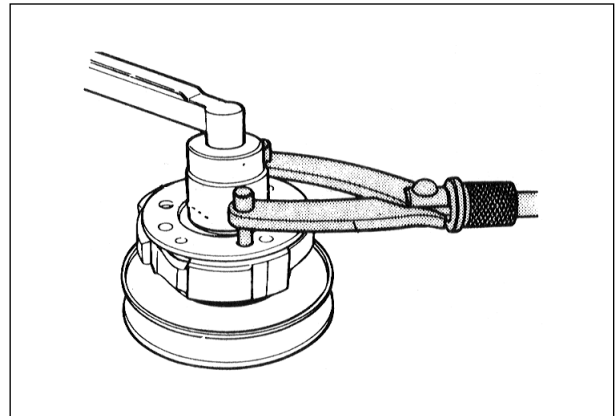
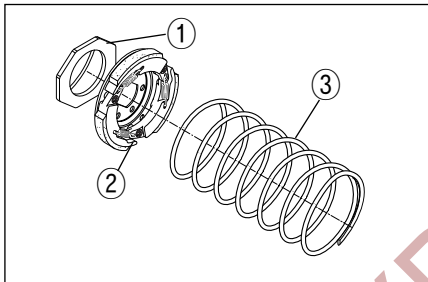

⚠ CAUTION

Do not attempt to disassemble the clutch shoe assembly. It is not serviceable.

- Using a thin blade screwdriver or the like, pry up the movable driven face spring guide (4).

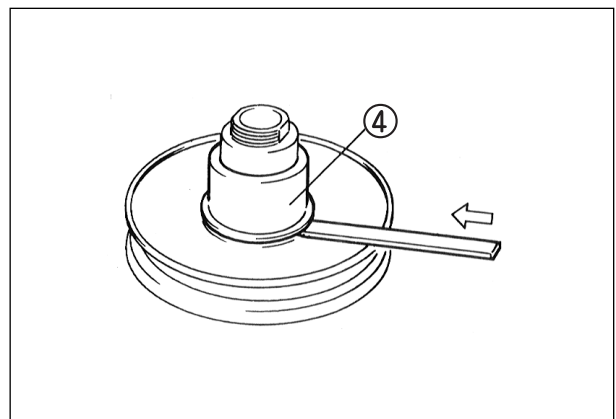

- Remove the pins (5), movable driven face (6) and fixed driven face (7).

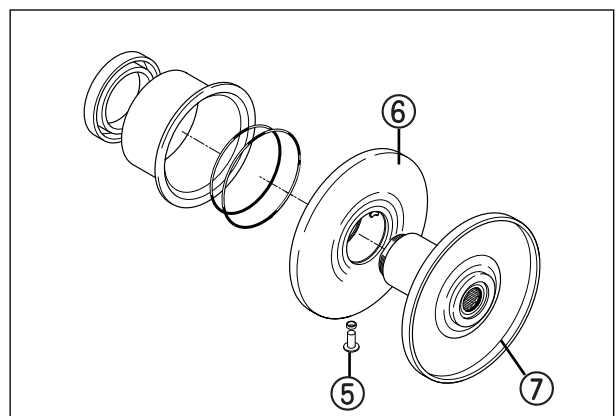

3-11 ENGINE

- Remove the needle bearing ① with the special tools.

 Bearing remover(17mm) : 09923-73210

Rotor remover sliding shaft : 09930-30102

 **CAUTION**

The removed bearing should be replaced with a new one.

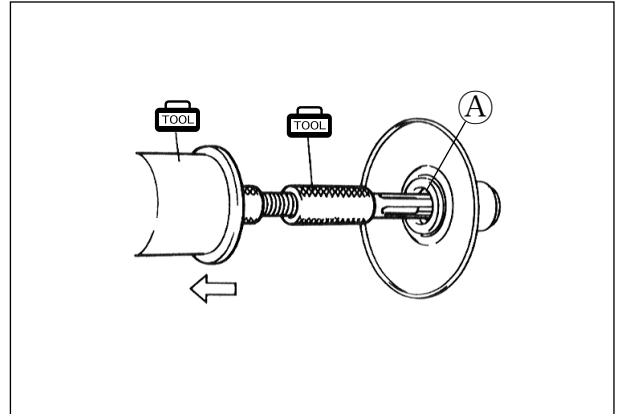

- Remove the circlip ②.

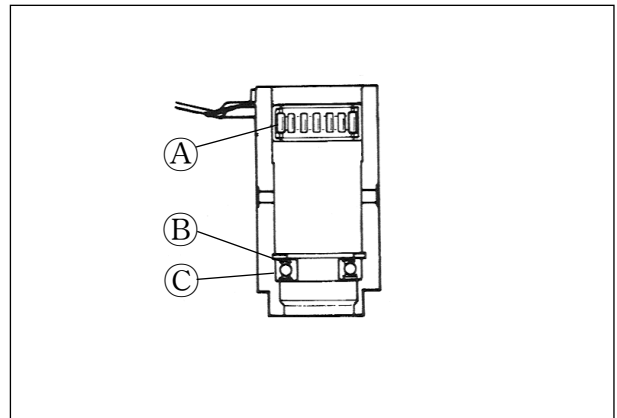
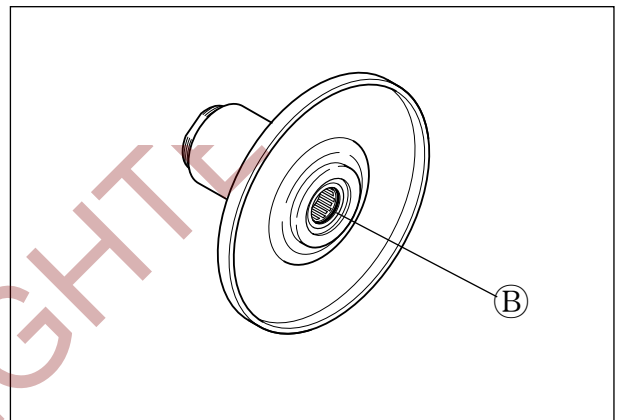

- Remove the bearing ③ with the special tool.

 Wheel bearing remover : 09941-50111

 **CAUTION**

The removed bearing should be replaced with a new one.

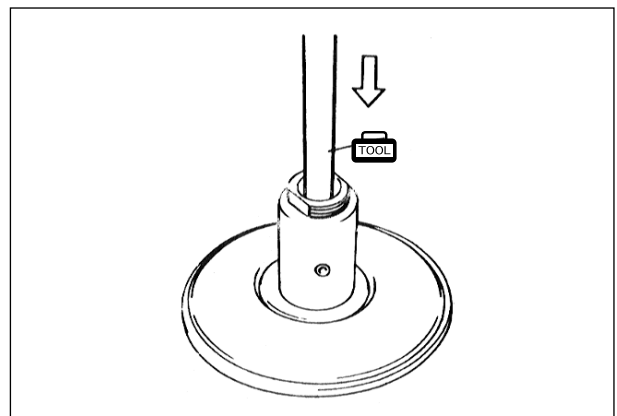

⦿ TRANSMISSION

- Drain transmission oil.
- Remove the gear box cover ①.
- Remove the drive shaft ②.

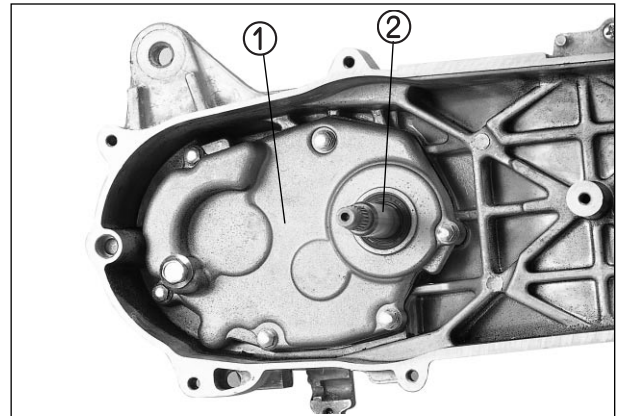

- Remove the oil seal ③ from the gear box cover with the special tool.

 **Oil seal remover : 09913-50121**

CAUTION

The removed oil seal should be replaced with a new one.

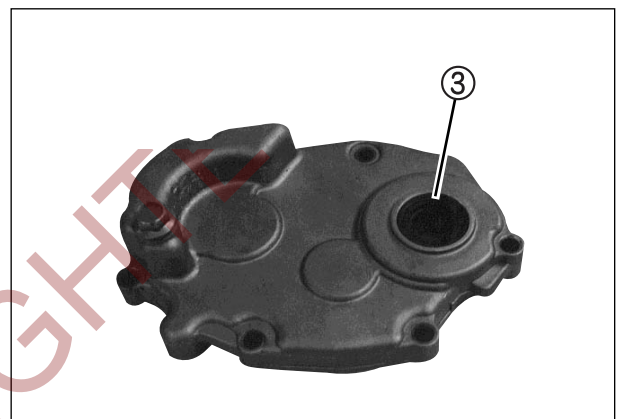

- Remove the bearing ④ with the special tool.

 **Bearing installer : 09943-88211**

CAUTION

The removed bearing should be replaced with a new one.

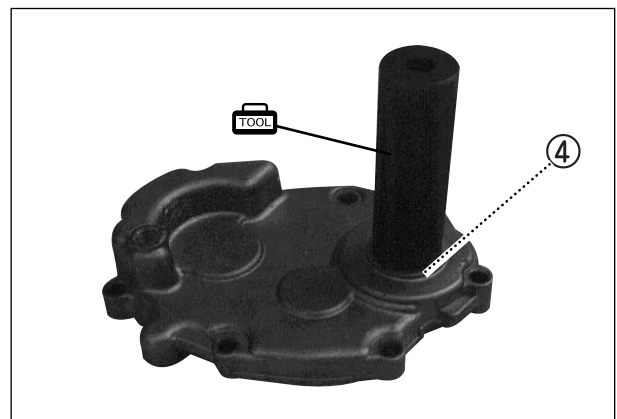

- Remove the circlip ⑤ and final driven gear ⑥.
- Remove the idle shaft ⑦.
- Remove the drive shaft bearing ⑧ and idle shaft bearing.

 **Rotor remover sliding shaft : 09930-30102**
Bearing remover (12mm) : 09921-20210

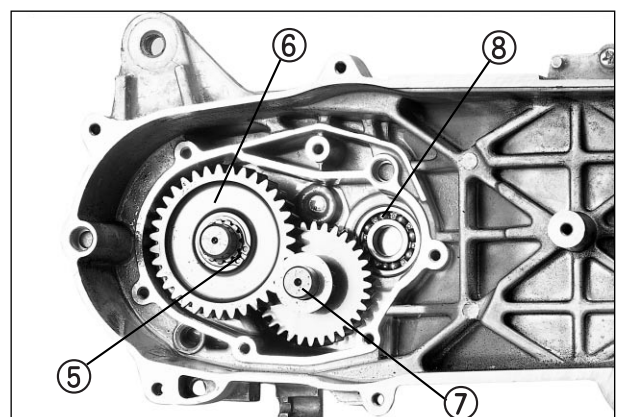

3-13 ENGINE

● CRANKCASE

● Remove the crankcase securing screws.

 Crankcase separator : 09920-13120

NOTE :

Loosen the crankcase screws diagonally.

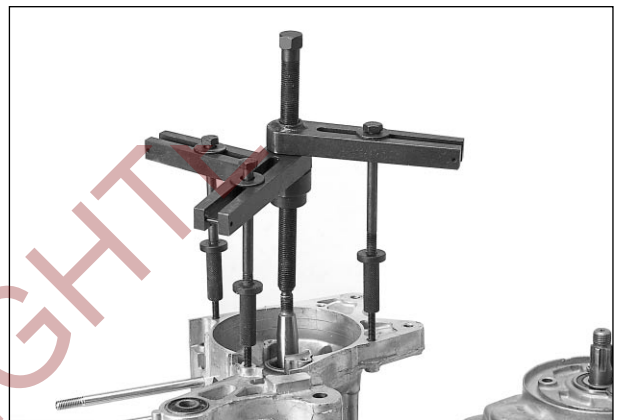
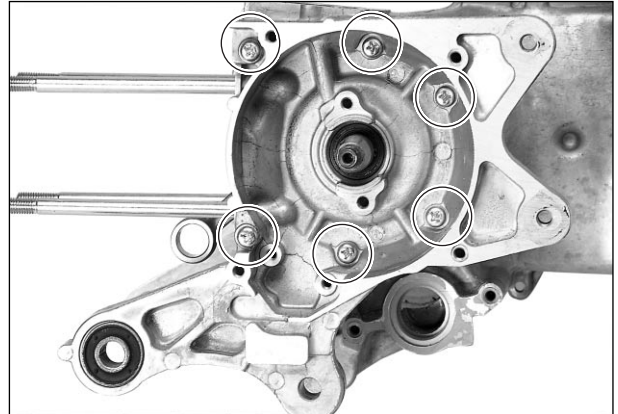

● Remove the crankshaft with the special tool.

 Crankcase separator : 09920-13120



- Remove the bushing.

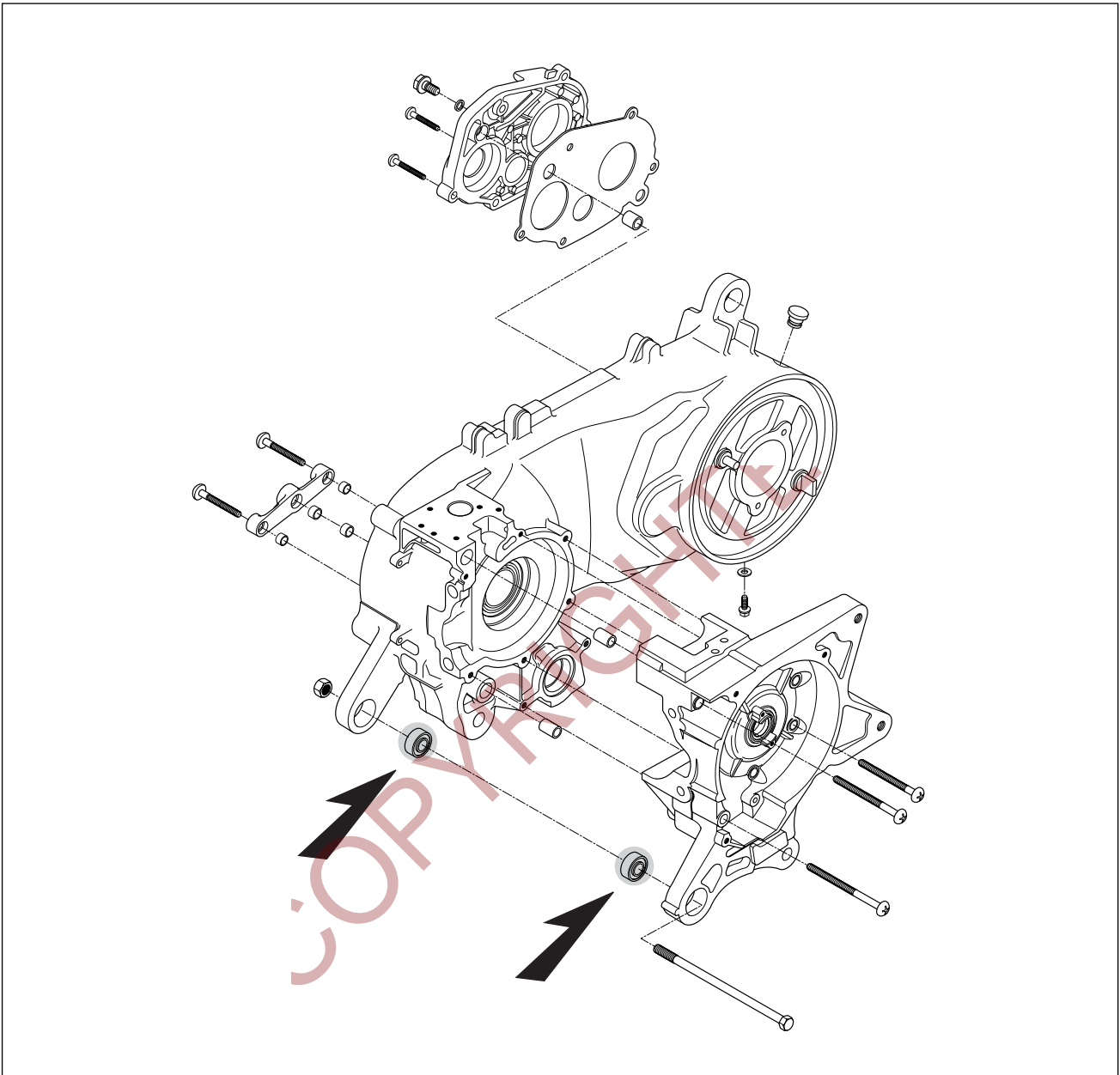

- Using two steel tubes of appropriate size, press out the engine mounting bushings on a vise as shown in the illustration.

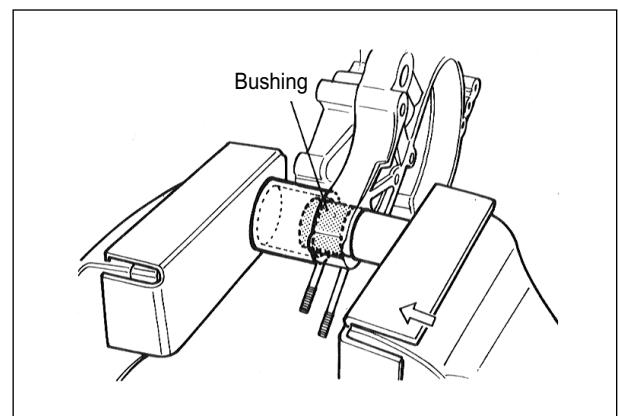

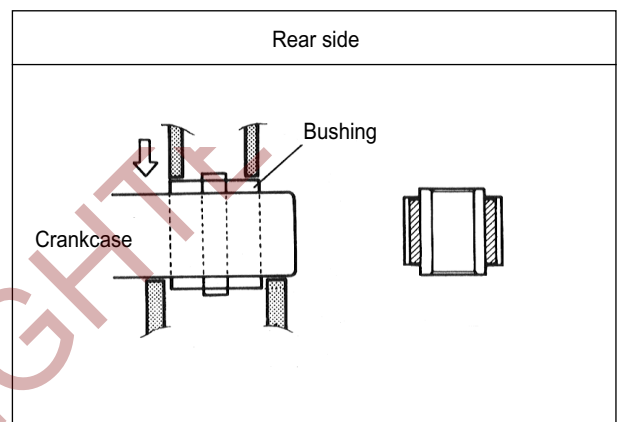
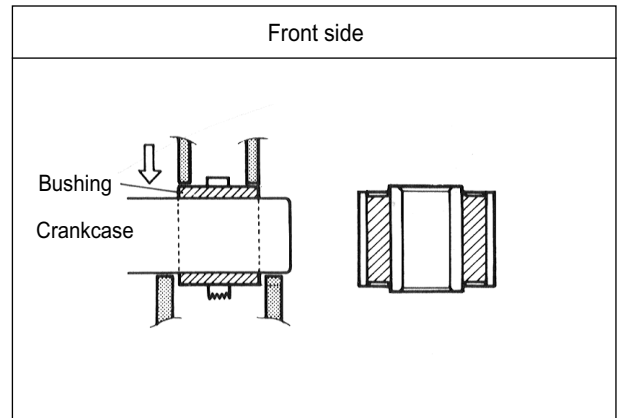

COPYRIGHT

ENGINE COMPONENTS INSPECTION AND SERVICING

BEARINGS

Wash the bearing with cleaning solvent and lubricate with motor oil before inspecting.

Turn the inner ring and check to see that the inner ring turns smoothly. If it does not turn lightly, quietly and smoothly, or if noise is heard, the bearing is defective and must be replaced with a new one.

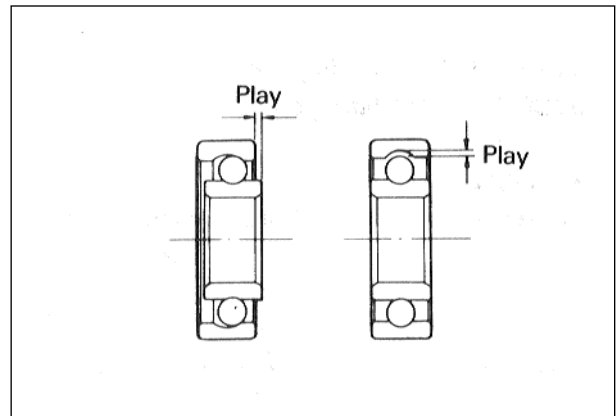

OIL SEALS

Damage to the lip of the oil seal may result in leakage of the fuel-air mixture or oil. Inspect for damage and be sure to replace the damaged seal if found.

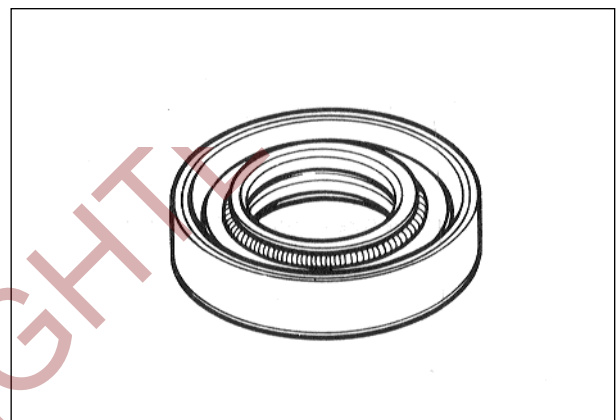

CRANKSHAFT

⊙ CRANKSHAFT RUNOUT

Support the crankshaft by the V-blocks, with the dial gauge rigged to read the runout as shown.

Crankshaft runout	Service limit
	0.05 mm (0.002 in)

TOOL V-block : 09943-21304
Magnetic stand : 09900-20701
Dial gauge : 09900-20606

Excessive the crankshaft runout is often responsible for abnormal engine vibration. Such vibration shortens engine life.

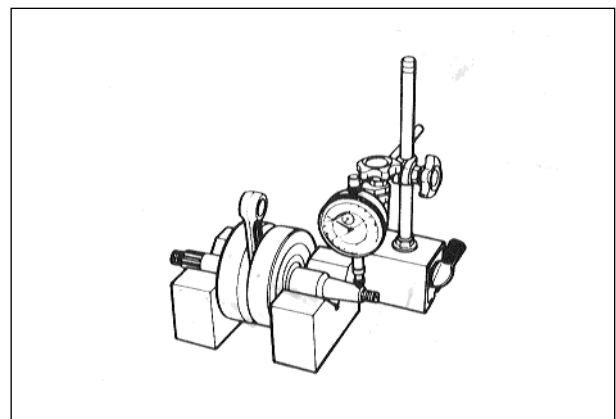

⊙ WEAR AND CLEARANCE OF CONROD BIG END

Turn the crankshaft with the conrod to feel the smoothness of rotary motion in the big end. Move the rod up and down while holding the crankshaft rigidly to be sure that there is no rattle in the big end.

Wear on the big end of the conrod can be estimated by checking the movement of the small end of the rod. This method can also check the extent of wear on the parts of the conrod s big end.

If wear exceeds the limit, conrod, crank pin and crank pin bearing should all be replaced.

Conrod big end runout	Service limit
	3.0 mm (0.12 in)

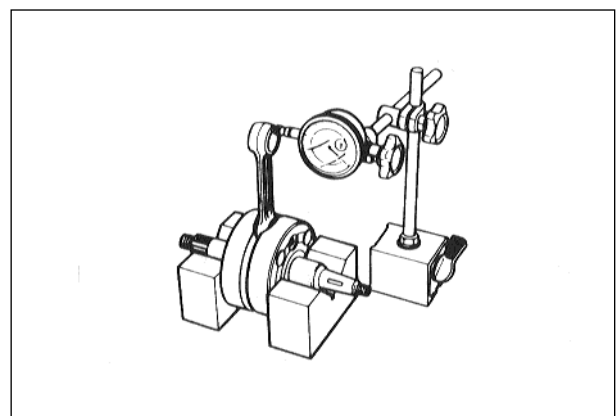

3-17 ENGINE

⦿ CONROD SMALL END BORE I.D.

Measure the conrod small end diameter with a caliper gauge.

Conrod small end bore I.D.	Service limit
	16.040mm (0.632 in)

 **Dial calipers : 09900-20605**

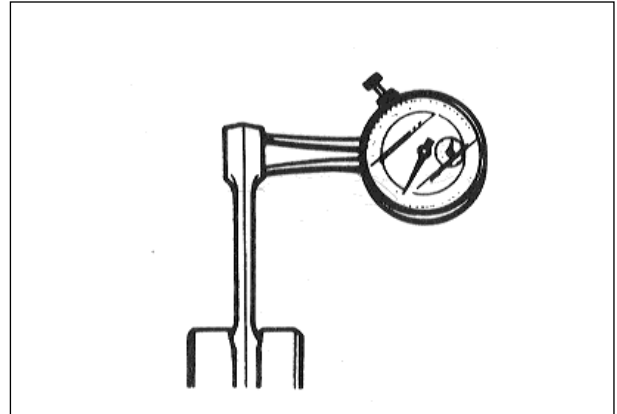

AUTOMATIC CLUTCH INSPECTION

This vehicle is equipped with an automatic clutch and variable ratio belt drive transmission. The engagement of the clutch is governed by engine RPMs and centrifugal mechanism located in the clutch.

To insure proper performance and longevity of the clutch assembly it is essential that the clutch engages smoothly and gradually. Two inspection checks must be performed to thoroughly check the operation of the drivetrain. Follow the procedures listed.



⦿ CLUTCH-IN INSPECTION

Warm the engine to normal operating temperature. Connect an engine tachometer to the engine.

Seated on the vehicle with the vehicle on level ground, increase the engine RPMs slowly and note the RPM at which the vehicle begins to move forward.

Clutch-in RPM	Standard	3,900 rpm
	Tolerance	± 200 rpm

 **Engine tachometer : 09900-26006**



⦿ CLUTCH TIGHT INSPECTION

Grip the front brake lever and depress rear brake pedal fully, and measure the engine RPM when open the throttle.

Warm the engine to normal operating temperatures.

Connect an engine tachometer to the engine.

Apply the rear brake as firm as possible.

Briefly open the throttle fully and note the maximum engine RPMs sustained during the test cycle.

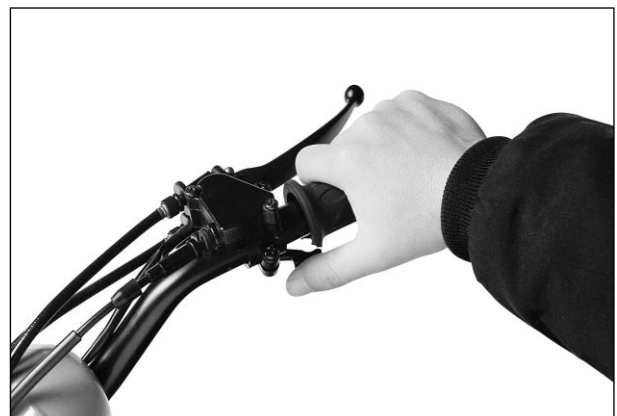

⚠ CAUTION

Do not apply full power for more than 3 seconds or damage to the clutch or engine may occur.

Clutch tight RPM	Standard	5,900 rpm
	Tolerance	±200 rpm

 **Engine tachometer : 09900-26006**

If the engine RPM does not coincide with the specified RPM range, then disassemble the clutch.

Clutch shoe - inspect the shoes visually for chips, cracking, uneven wear and burning, and check the thickness of the shoes with vernier calipers. If the thickness is less than the following service limit, replace them as a set.

Clutch springs - visually inspect the clutch springs for stretched coils or broken coils.

Clutch shoe thickness	Service limit
	2.0 mm (0.079 in)

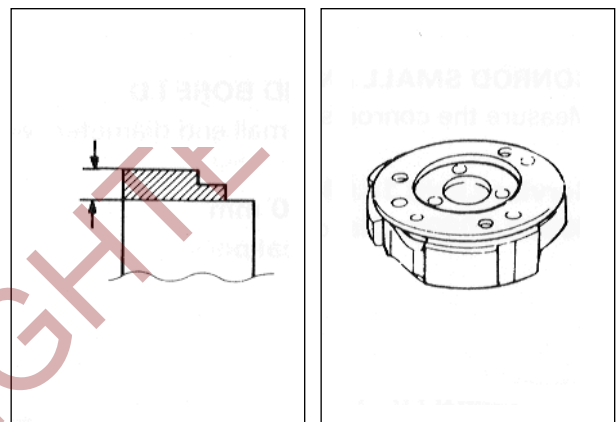
**⚠ CAUTION**

Clutch shoes or springs must be changed as a set and never individually.

Clutch housing - inspect visually the condition of the inner clutch housing surface for scrolling, cracks, or uneven wear. Measure inside diameter at several points to check for an out-of-round condition as well as wear.

Clutch housing I.D.	Service limit
	112.50 mm (4.429 in)

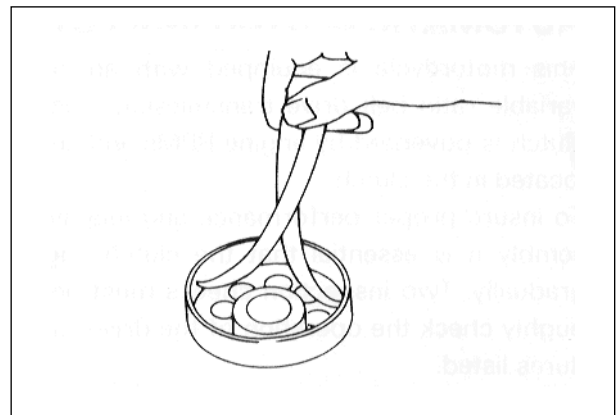

3-19 ENGINE

⦿ DRIVE V-BELT

Remove the drive V-belt and check for cracks, wear and separation. Measure the belt width with a vernier calipers. Replace it if the belt width is less than the service limit or any defect has been found.

Drive V-belt width	Service limit
	16.0 mm (0.630 in)

⚠ CAUTION

Always keep the belt away from any greasy material.

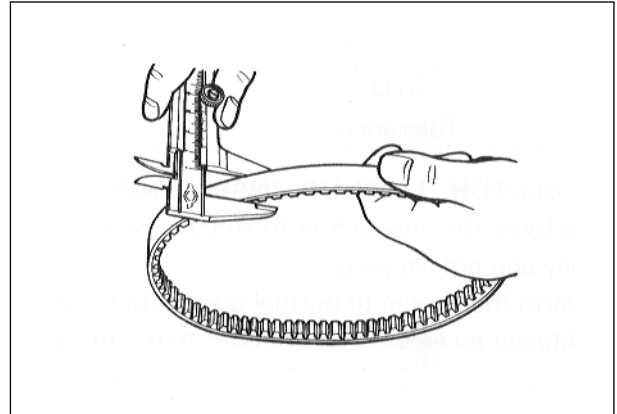

⦿ DRIVE FACE

Inspect the belt contact surface of the drive faces for wear, scratches or any abnormality. If there is something unusual, replace the drive face with a new one.

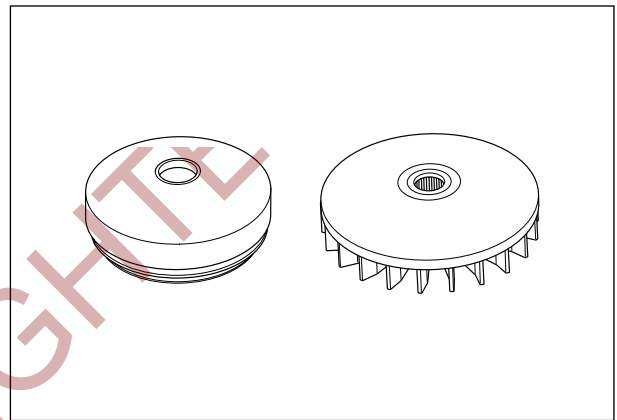

⦿ ROLLER AND MOVABLE DRIVE FACE

Inspect each roller and movable drive face for wear or damage.

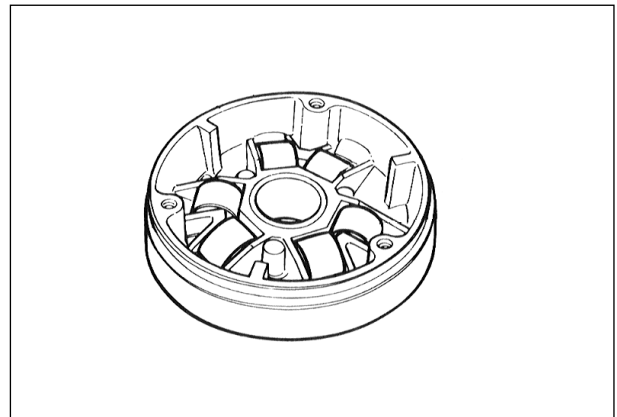

⦿ MOVABLE DRIVEN SPRING

Measure the free length of the movable driven spring. If the length is shorter than the service limit, replace the spring with a new one.

Movable driven spring free length	Service limit
	130.0 mm (5.118 in)

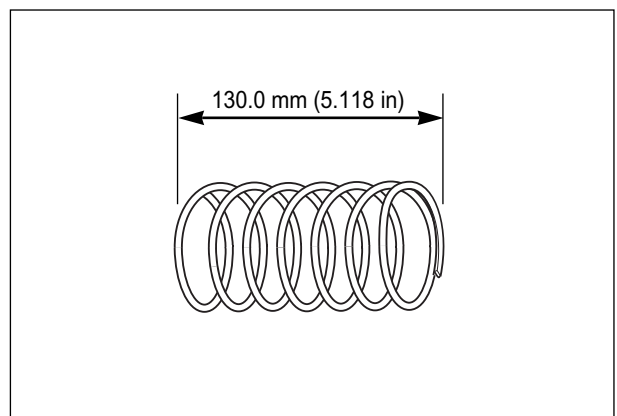

⊙ DRIVEN FACE PIN AND OIL SEAL

Turn the driven faces and check to see that the driven faces turn smoothly.

If any stickness or hitches are found, visually inspect the lip of seal, driven face sliding surface and sliding pins for wear or damage.

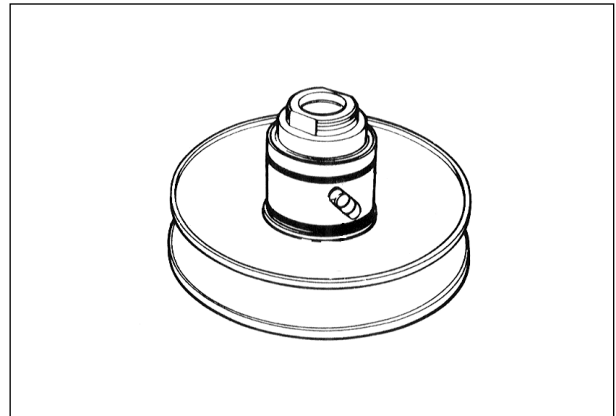

⊙ DRIVEN FACE

Inspect the belt contacting surface of both driven faces for any scratches, wear and damage.

Replace driven face with new one if there are any abnormality.

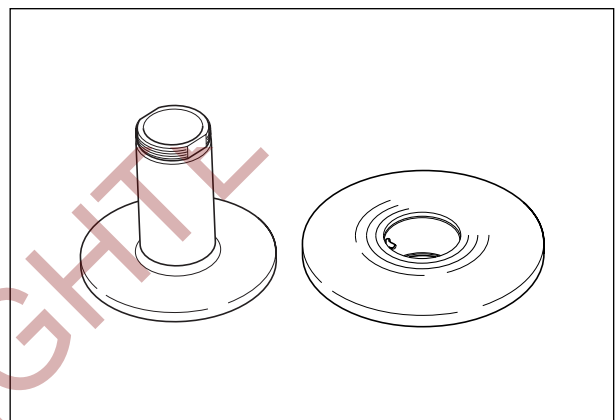

CYLINDER HEAD

Decarbon the combustion chamber.

Check the gasketed surface of the cylinder head for distortion with a straightedge and thickness gauge, taking a clearance reading at several places.

Cylinder head distortion	Service limit
	0.05 mm (0.002 in)

 Thickness gauge : 09900-20806

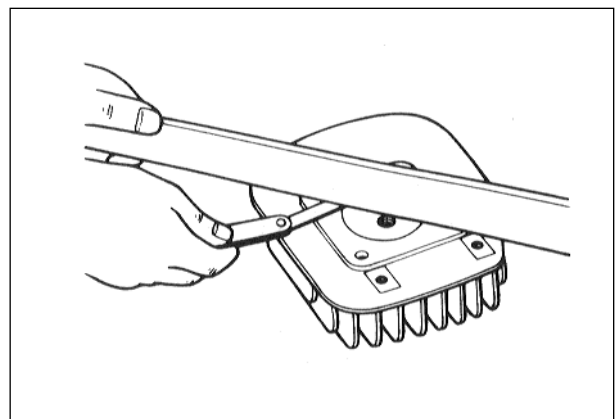

If the largest reading at any portion of the straight-edge exceeds the limit, rework the surface by rubbing it against emery paper (of about #400) laid flat on the surface plate in a lapping manner. The gasketed surface must be smooth and perfectly flat in order to secure a tight joint : a leaky joint can be the cause of reduced power output and increased fuel consumption.

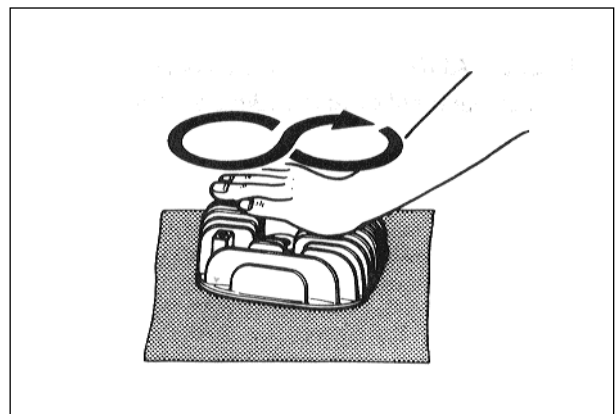

3-21 ENGINE

CYLINDER

Decarbon exhaust port and upper part of the cylinder, taking care not to damage the cylinder wall surface.

The wear of the cylinder wall is determined from diameter reading taken at 20mm from the top of the cylinder with a cylinder gauge. If the wear thus determined exceeds the limit indicated below, rework the bore to the next oversize by using a boring machine or replace the cylinder with a new one.

Cylinder bore	Service limit
	52.590 mm (2.071 in)

 **Cylinder gauge set : 09900-20508**

After reworking the bore to an oversize, be sure to chamfer the edges of ports and smooth the chamfered edges with emery paper. To chamfer, use a scraper, taking care not to nick the wall surface.

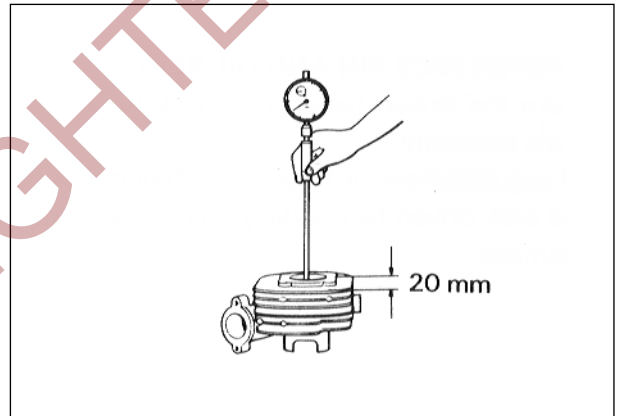
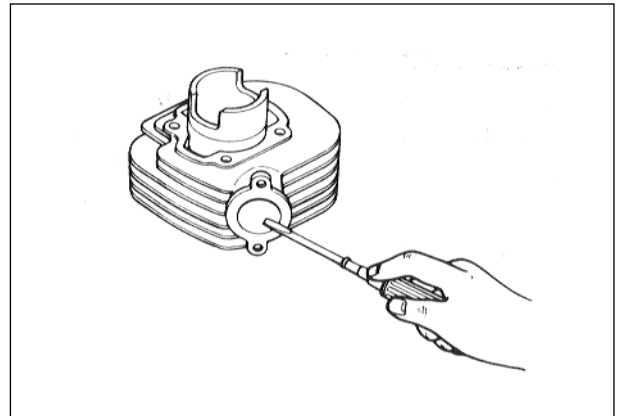

PISTON

⊙ CYLINDER TO PISTON CLEARANCE

Cylinder-to-piston clearance is the difference between piston diameter and cylinder bore diameter. Be sure to take the maked diameter at right angles to the piston pin. The value of elevation $\text{\textcircled{A}}$ is prescribed to be 20mm from the skirt end.

 **Micrometer(50 ~ 75mm) : 09900-20203**

Piston diameter	Service limit
	52.332 mm (2.060 in)

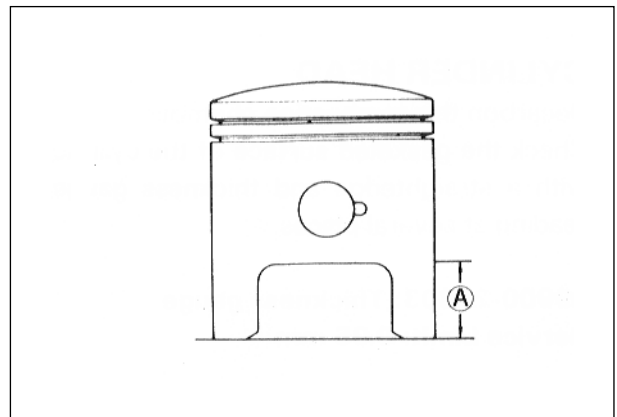

As a result of the above measurement, if the piston-to-cylinder clearance exceeds the following limit, overhaul the cylinder and use an oversize piston, or replace both cylinder and piston. The measurement for the bore diameter should be taken in the intake-to-exhaust port direction and at 20mm from cylinder top surface.

	Standard	Service limit
Cylinder bore	52.500~52.515mm (2.0669~2.0675 in)	52.590mm (2.0705 in)
Piston diameter	52.432~52.447mm (2.0643~2.0648 in)	52.332mm (2.0603 in)
Cylinder to piston clearance	0.073 ~ 0.083mm (0.0029~0.0033 in)	0.120mm (0.0047 in)

⦿ **DE-CARBONING**

De-carbon the piston and piston ring grooves, as illustrated. After cleaning the grooves, fit the rings and rotate them in their respective grooves to be sure that they move smoothly.

Carbon in groove is liable to cause the piston ring to get stuck in the groove, and this condition will lead to reduce engine power output.

A piston whose sliding surface is badly grooved or scuffed due to overheating must be replaced. Shallow grooves or minor scuff can be removed by grinding with emery paper of about #400.

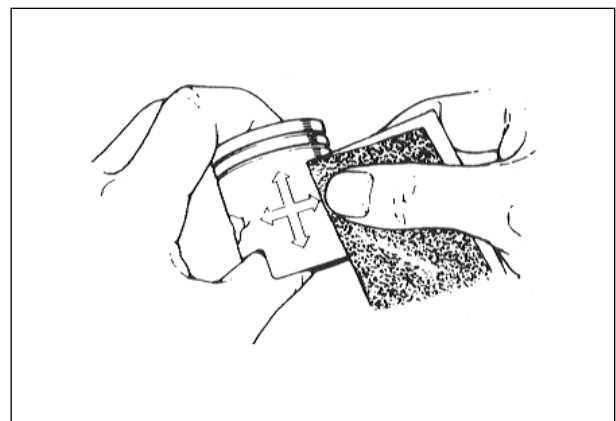
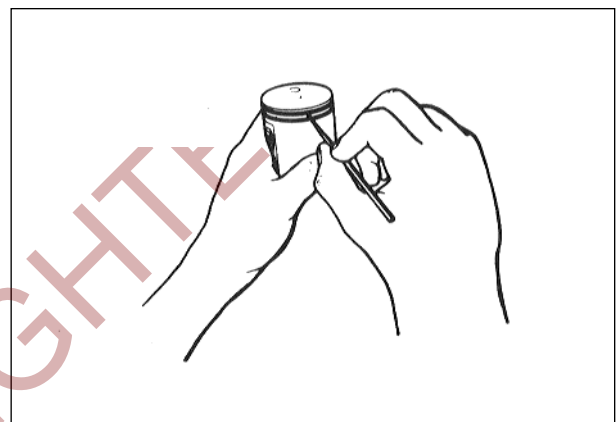
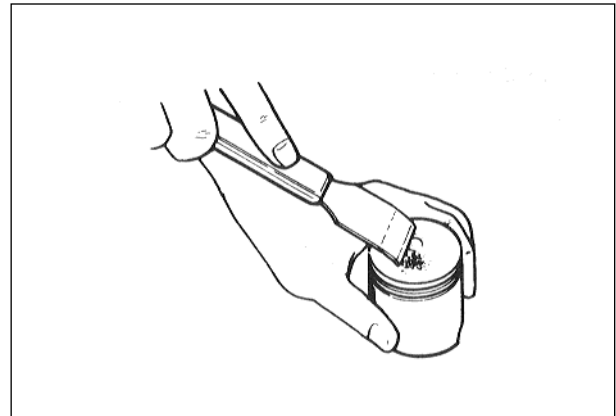

⦿ **PISTON PIN BORE I.D.**

Using a caliper gauge, measure the piston pin bore inside diameter. If reading exceeds the following service limit, replace it with a new one.

	Service limit
Piston pin bore I.D.	12.030 mm (0.474 in)

 **Dial calipers : 09900-20605**

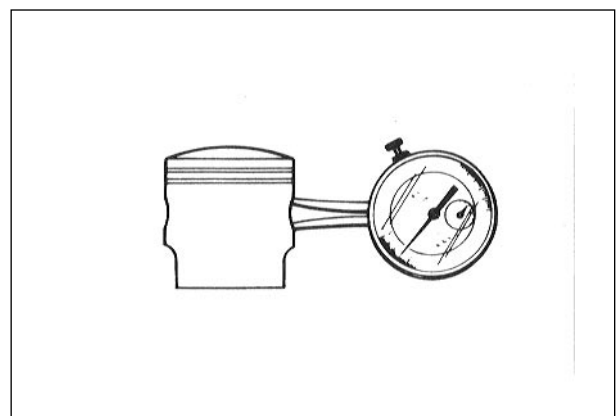

3-23 ENGINE

⊙ PISTON PIN O.D.

Using a micrometer, measure the piston pin outside diameter at three positions.

Piston pin O.D.	Service limit
	11.980 mm (0.472 in)

 **Micrometer(0~25mm) : 09900 - 20201**

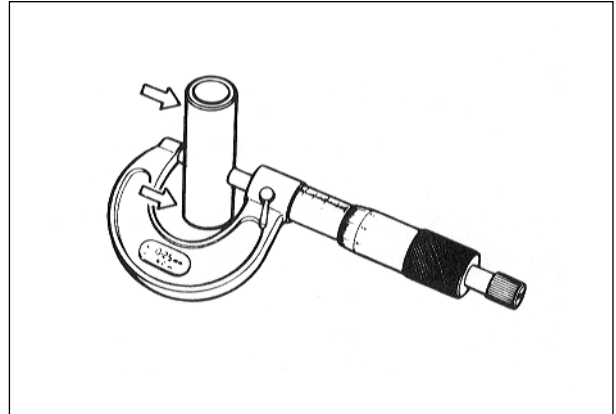

⊙ PISTON RINGS

Check each ring for the clearance, reading the clearance with a thickness gauge shown in the illustration. If the clearance is found to exceed the limit, indicated below, replace it with a new one.

The clearance of each ring is to be measured with the ring fitted squarely into the cylinder bore and held at the least worn part near the cylinder bottom, as shown in the illustration.

Piston ring clearance (Assembly condition)	Service limit
	0.75 mm (0.030 in)

 **Thickness gauge : 09900 - 20806**

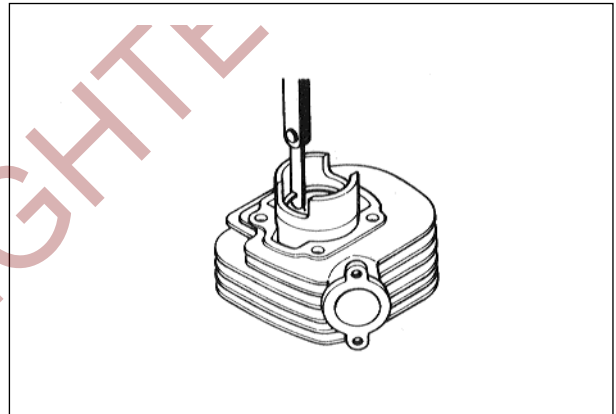

As the piston ring wears, its clearance increases reducing engine power output because of the resultant blow by through the enlarged clearance. Here lies the importance of using piston rings with the clearance within the limit.

Measure the piston ring free clearance to check the spring tension.

Piston ring clearance (Free condition)	Service limit
	3.6 mm (0.142 in)

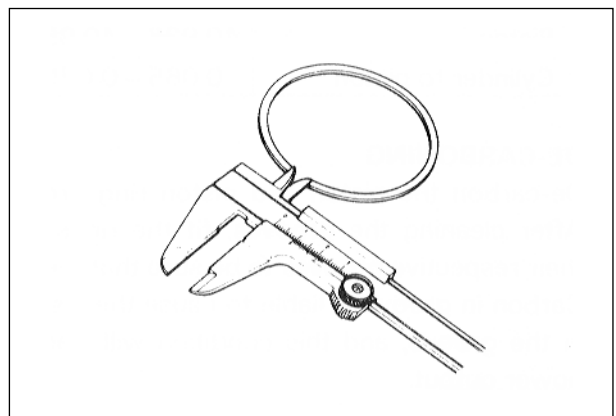

Fix the piston ring in the piston ring groove, measure the ring side clearance with the thickness gauge while matching the sliding surfaces of piston and ring.

Piston ring - groove clearance	Standard
1st	0.02~0.06 mm (0.0008 ~ 0.0024 in)
2nd	0.02~0.06 mm (0.0008 ~ 0.0024 in)

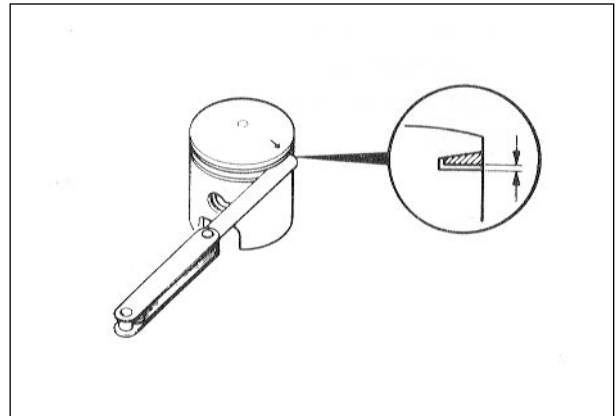

REED VALVE

When reinstalling the reed valve and stopper plate to the body, align the both cut on the reed valve and stopper plate.

Apply **THREAD LOCK "1324"** to the stopper plate securing screws.

 **THREAD LOCK : "1324"**



ENGINE REASSEMBLY

Reassembly is generally performed in the reverse order of disassembly, but there are a number of reassembling steps that demand or deserve detailed explanation or emphasis.

These steps will be taken up for respective parts and components.

OIL SEALS

Fit the oil seals to the crankcase following the procedure below.

Replace removed oil seals with new ones.

- Coat **SUPER GREASE "A"** to the lip of the oil seals.

 **SUPER GREASE "A"**

- Be sure to apply **THREAD LOCK "1324"** to outer surfaces of right and left crankshaft oil seals to prevent them from moving.

 **THREAD LOCK "1324"**

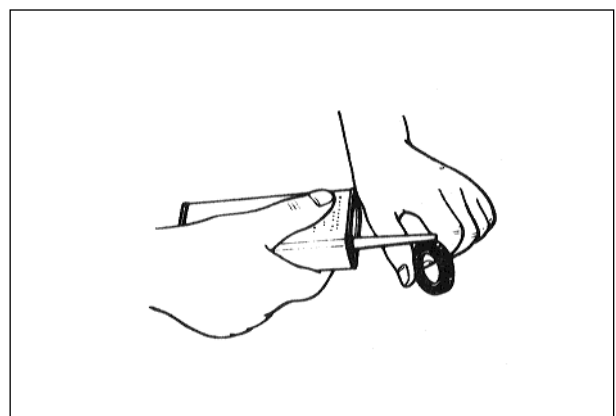

3-25 ENGINE

- When fitting the oil seal in the crankcase, insert it slowly with the special tools.

 **Oil seal installer : 09913-75830**
Bearing installer attachment : 09924-74510
Bearing installer pilot : 09924-74540

NOTE :

*Align the oil seal with edge **A** of the crankcase as shown in the illustration.*

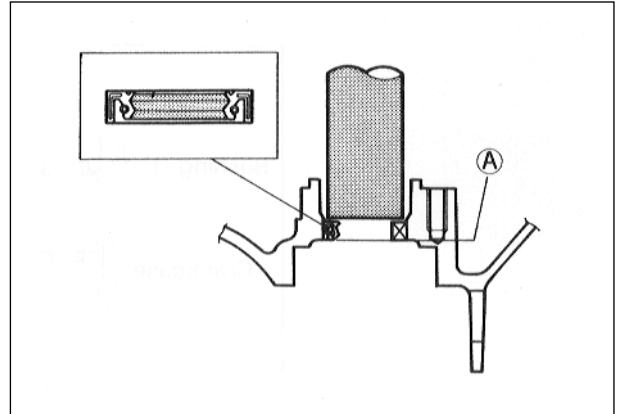

BEARINGS

Install new bearings ①, ②, ③ with the special tool.

 **Bearing installer : 09913-75810**
Bearing installer : 09913-76010

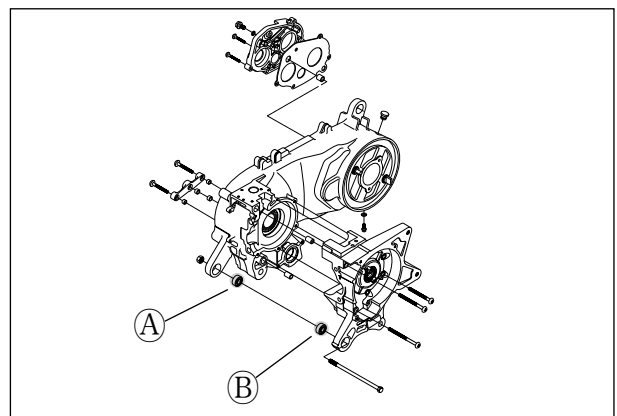
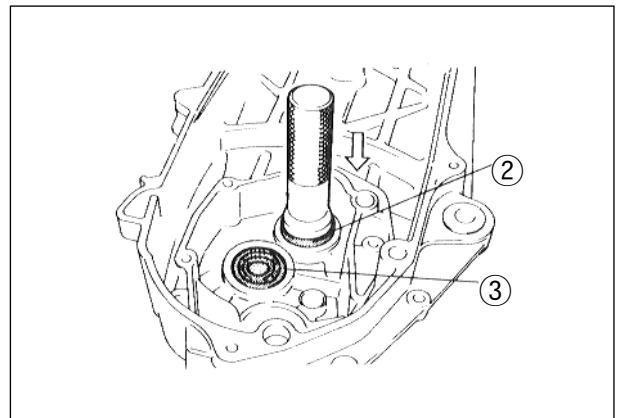
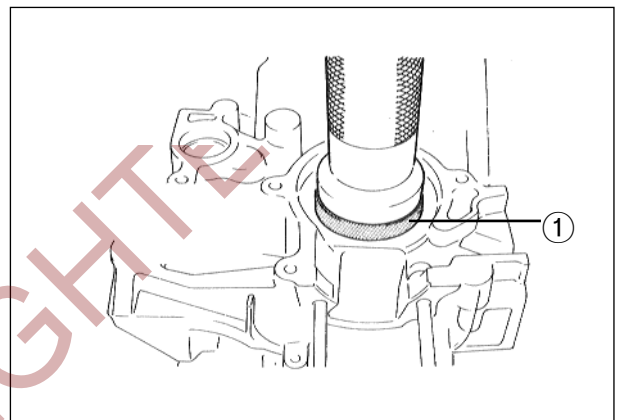

BUSHINGS

Using two steel tubes of appropriate size and a vise, press the mounting bushings **A** and **B** into the crankcase holes as shown in the illustration.

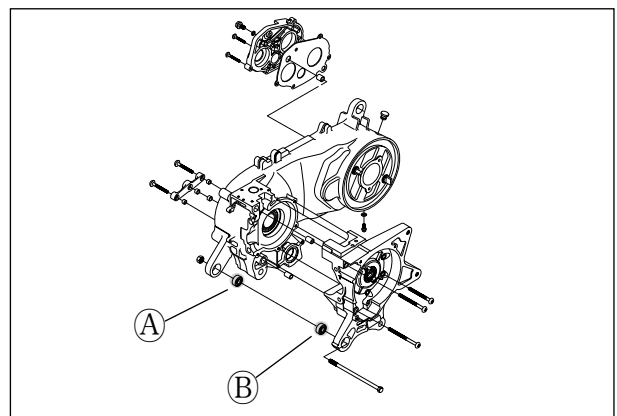

NOTE :

Knurled end ⑤ should face inside. Protrusive ③ and ④ should be in the same dimension.

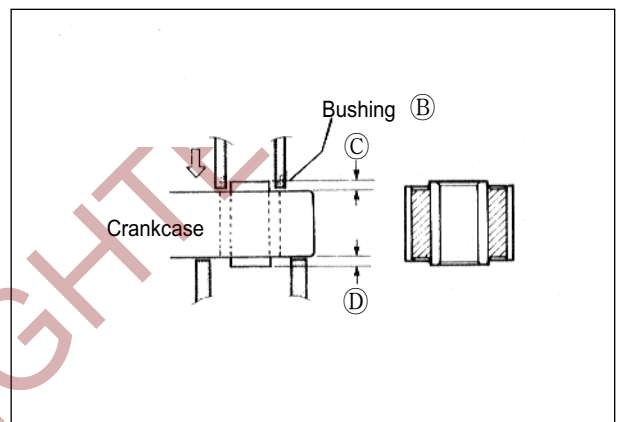
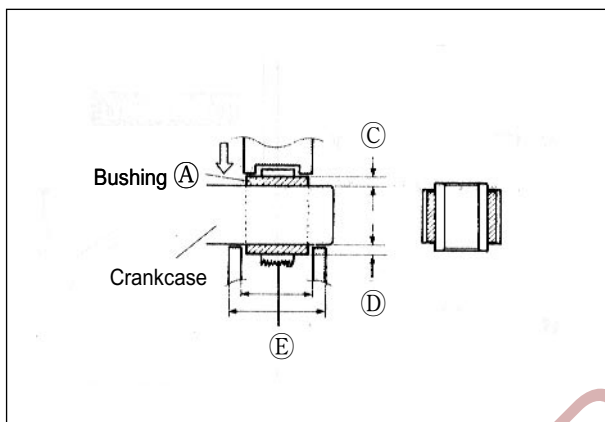
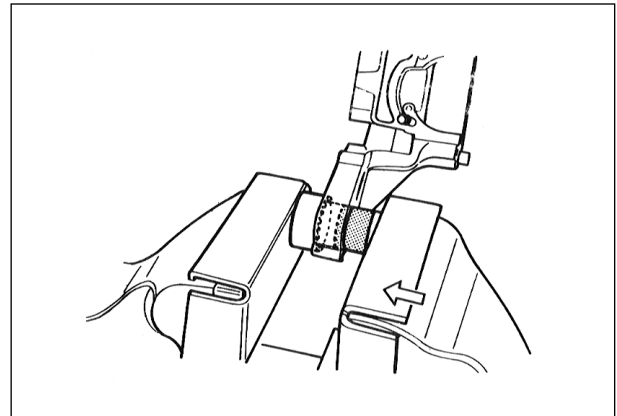

CRANKSHAFT

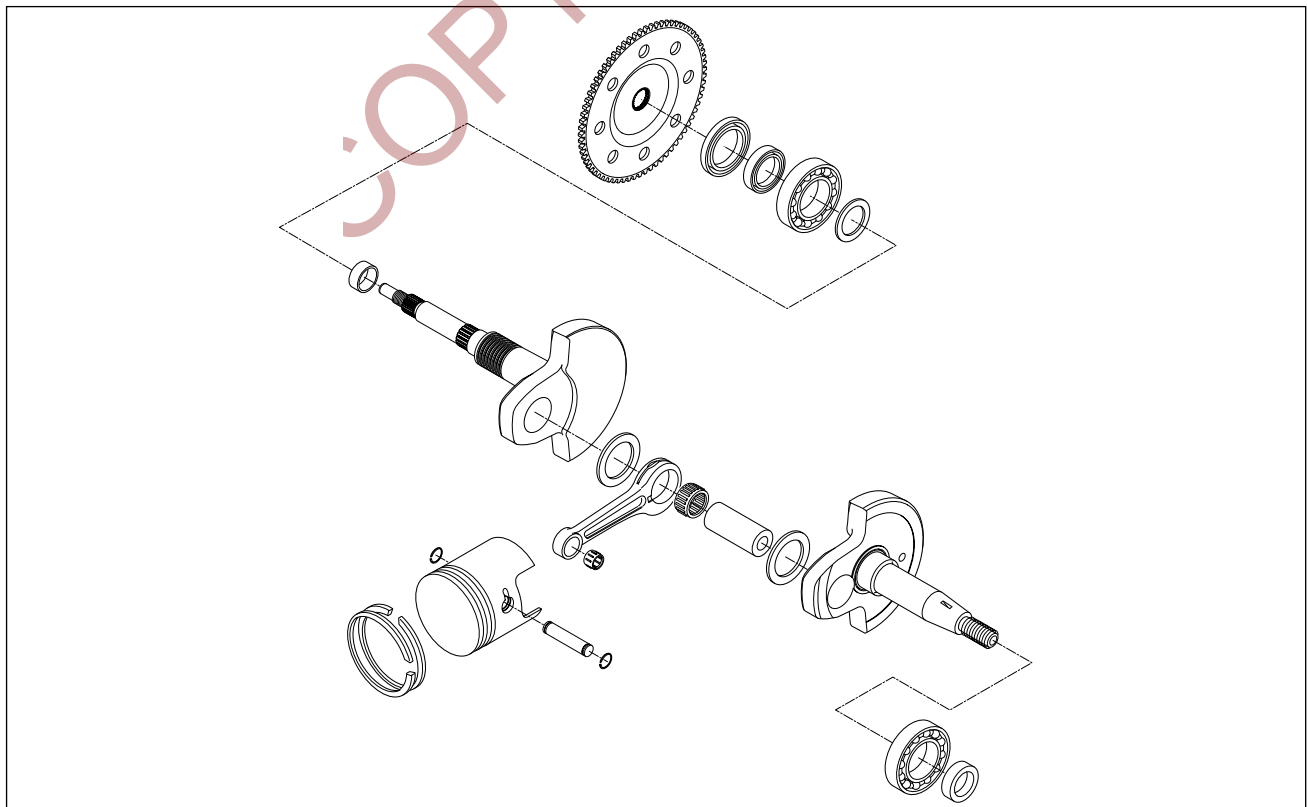

3-27 ENGINE

- Measure the length between the webs referring to the figure at right when rebuilding the crankshaft.

	Standard
Crank web to web width	40.0 ± 0.1 mm (1.575 ± 0.004 in)

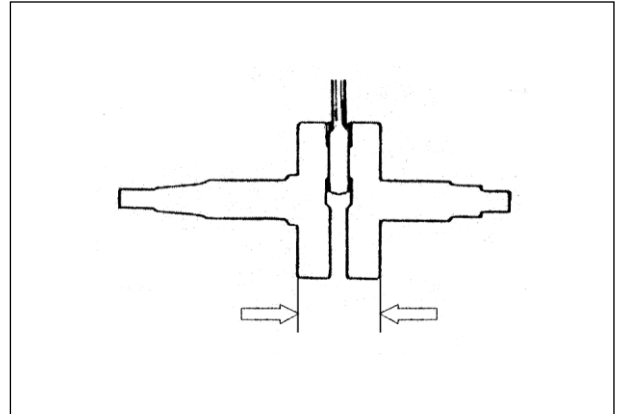

- When mounting the crankshaft into the crankcase, it is necessary to pull its left end into the crankcase with the special tool.

 **Crankshaft installer : 09900-32812**
Conrod holder : 09910-20116

CAUTION

Never fit the crankshaft into the crankcase by driving it with a plastic hammer. Always use the special tool, otherwise crankshaft alignment accuracy will be affected.

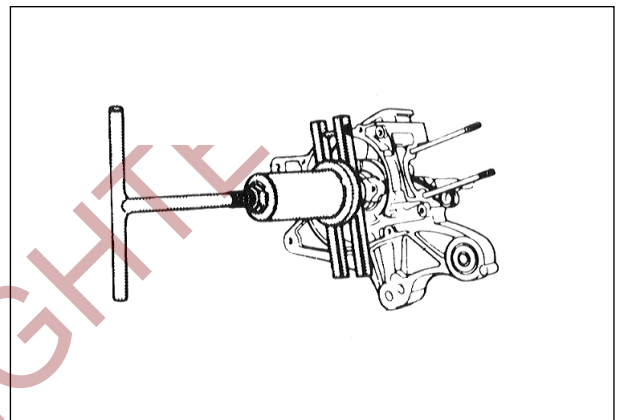

CRANKCASE

- Wipe the crankcase mating surfaces (both surfaces) with cleaning solvent.
- Apply **BOND "1215"** uniformly to the mating surface of the left half of the crankcase, and install the dowel pins.

 **BOND "1215"**

- Install the two dowel pins.

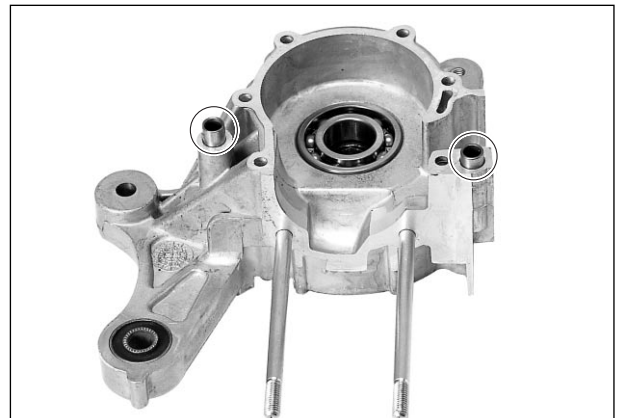

- Tighten the crankcase screws securely.
- Check if crankshaft rotates smoothly.

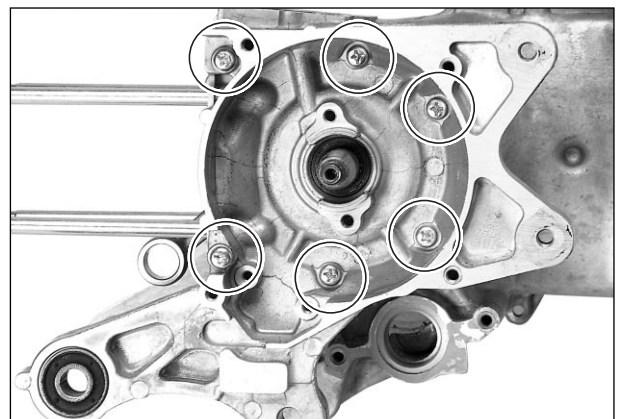

- Install the new oil seal ① to the crankcase with the special tool.

 **Bearing installer : 09913-85210**

NOTE :

Align the oil seal with edge ① of the crankcase as shown in the illustration.

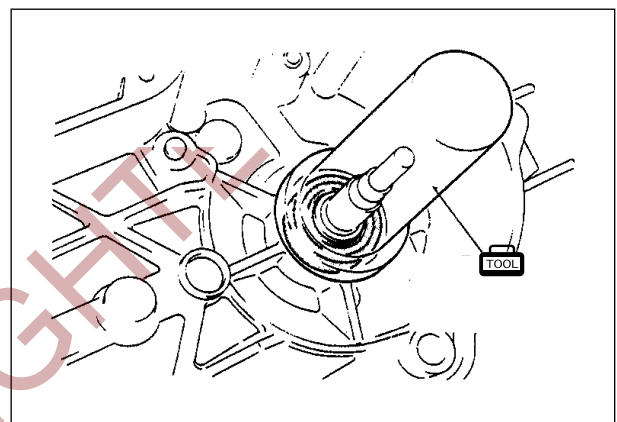
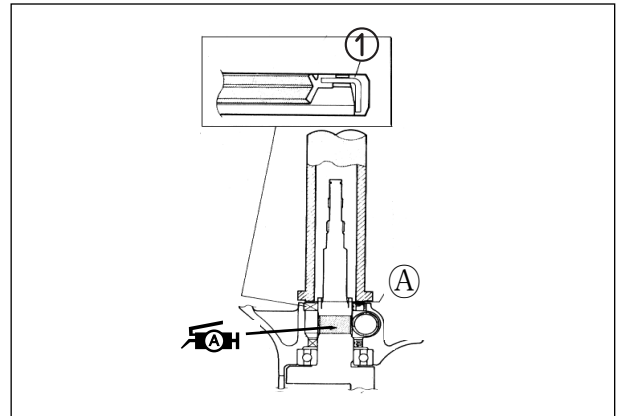

TRANSMISSION

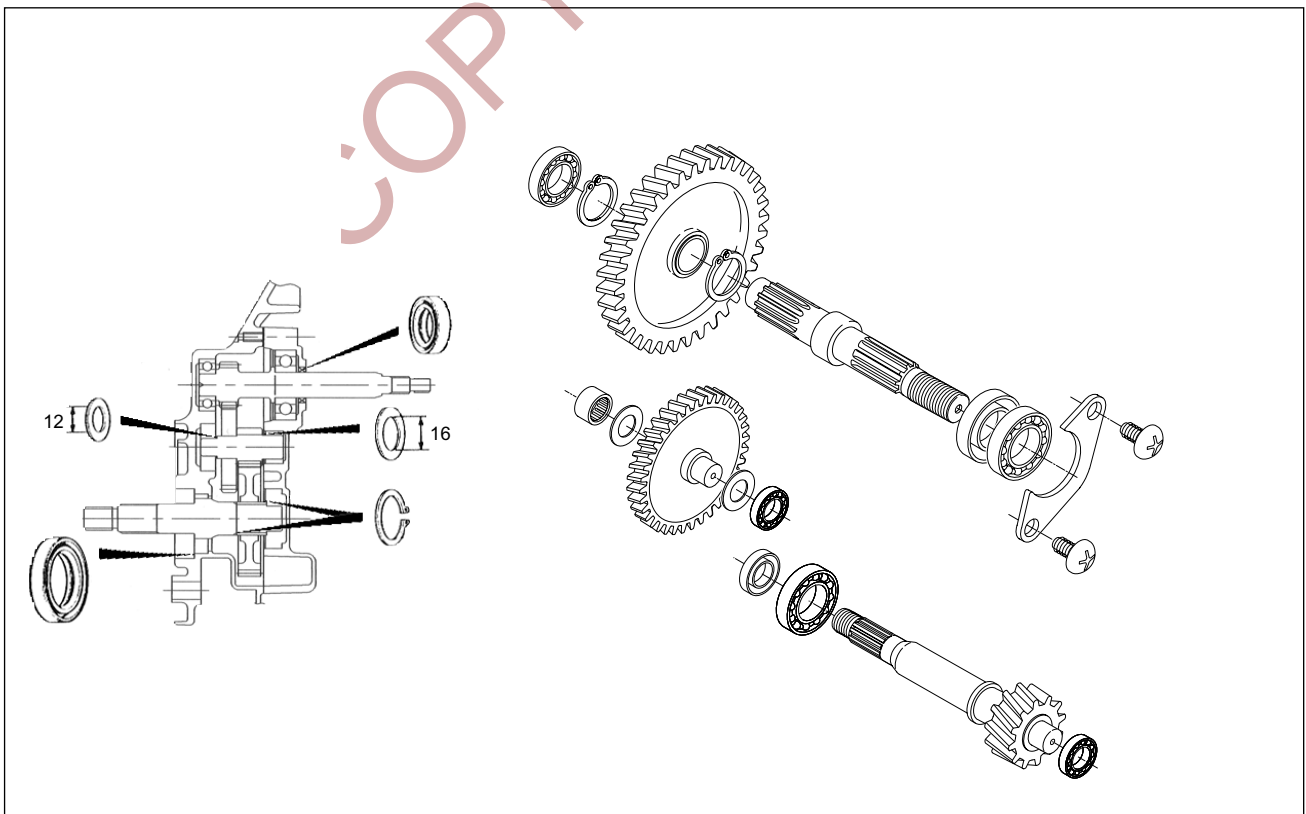

3-29 ENGINE

- Install the circlip ① on to the rear axle shaft ② .
- Assemble the idle shaft subassembly using the idle shaft ③ and thrust washer ④, then install the sub-assembly on the gear box.

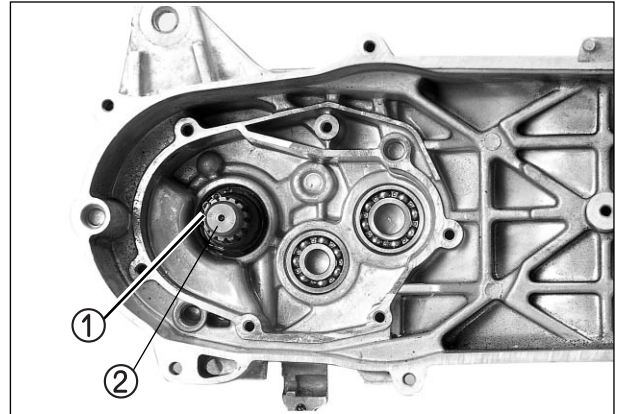
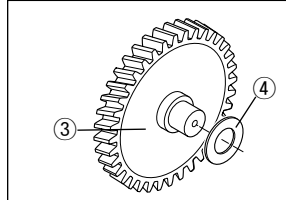

- Install the final driven gear ⑤ on the rear axle shaft using the circlip ⑥ .

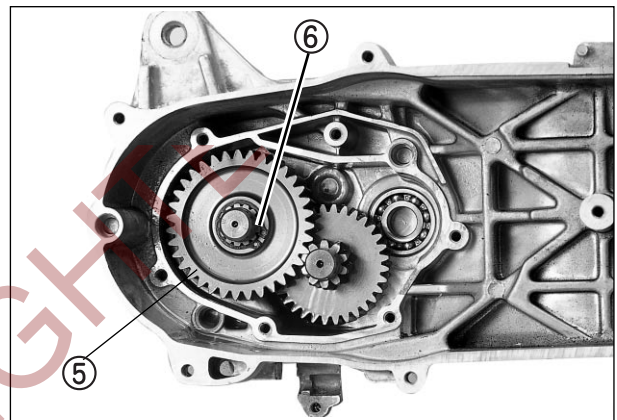
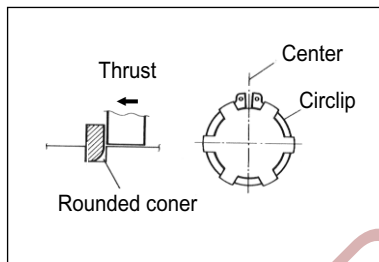

- Install the idle thrust washer ⑦, new gasket and dowel pin ⑧ .
- Install the driveshaft ⑨ to the gear box cover.

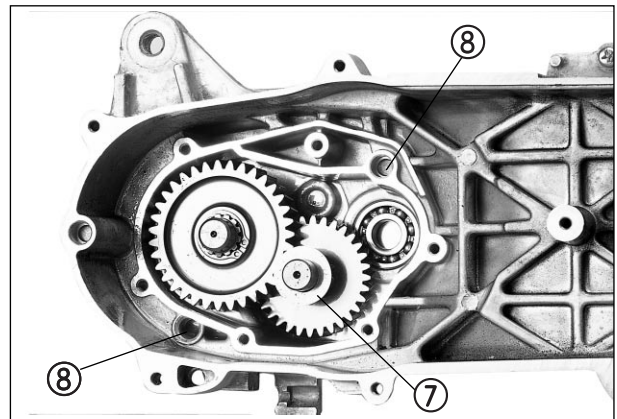
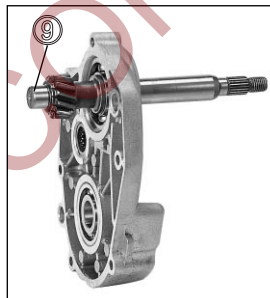

- Install the gear box cover ⑩ on the crankcase.
- Tighten all the screws evenly one by one in a diagonal fashion.

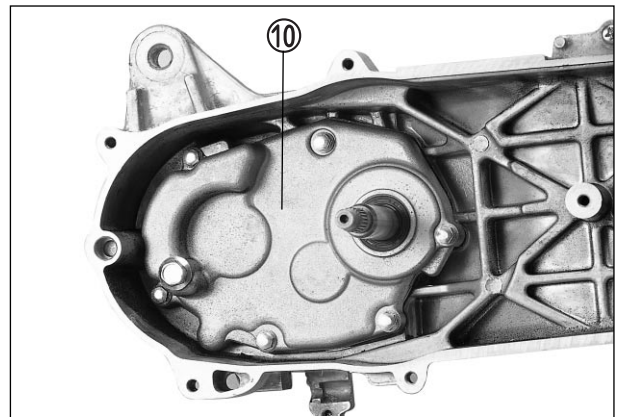

STARTER PINION, STARTER DRIVEN GEAR AND STARTER MOTOR

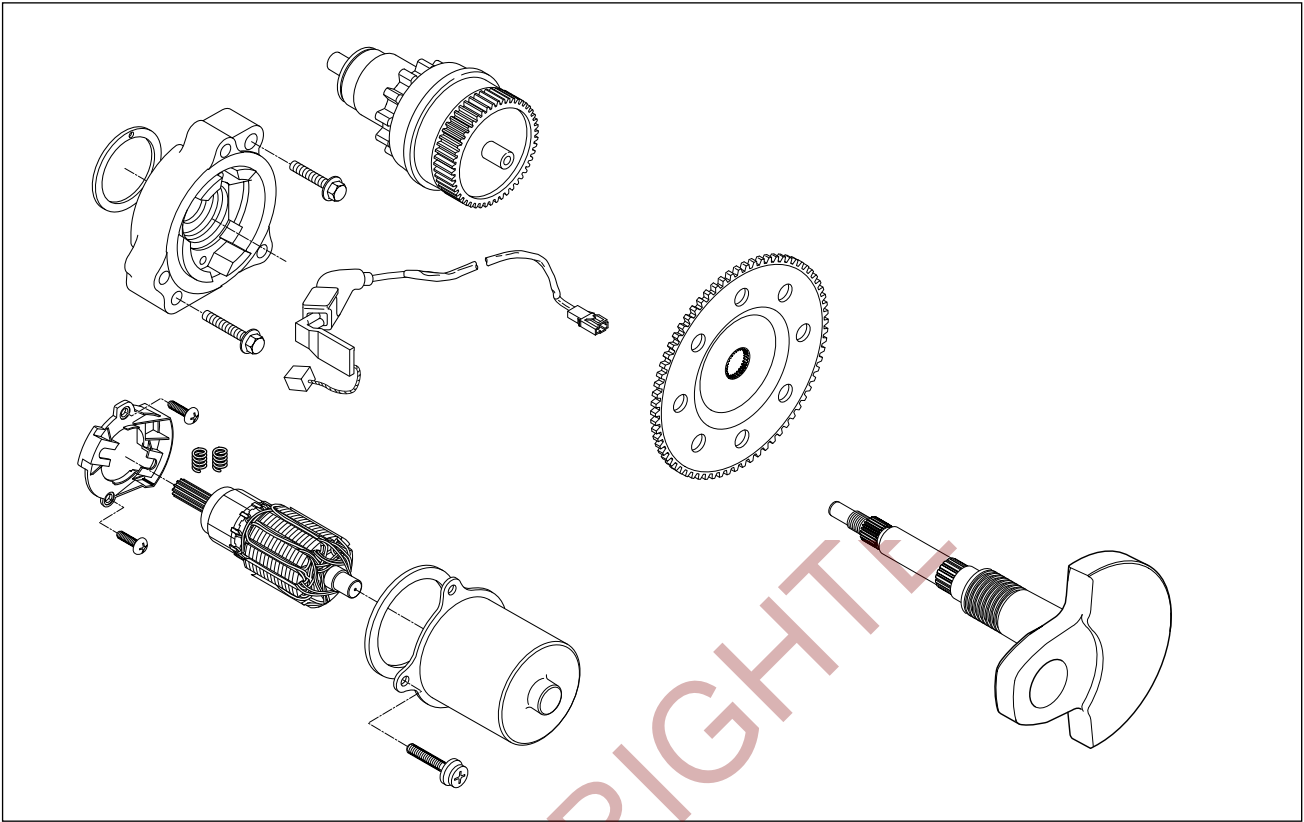

- Apply **SUPER GREASE "A"** on the pinion shaft and install the starter pinion subassembly.

 **SUPER GREASE "A"**

- Assemble the starter pinion subassembly ①.
- Insert the two dowel pins ② on the crankcase.

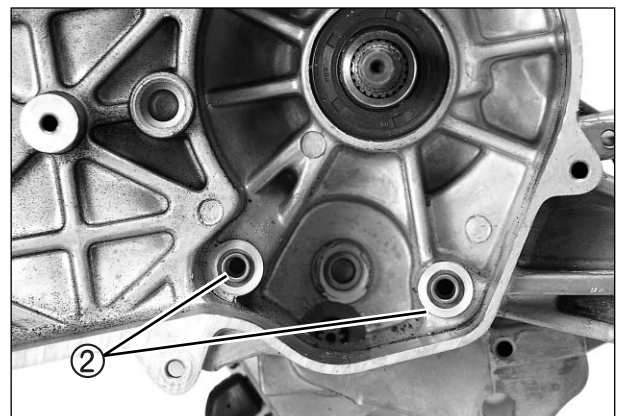
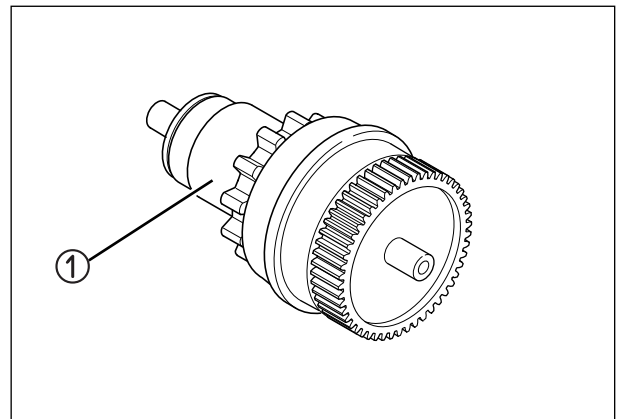

3-31 ENGINE

- Install the starter idle gear cap ①.

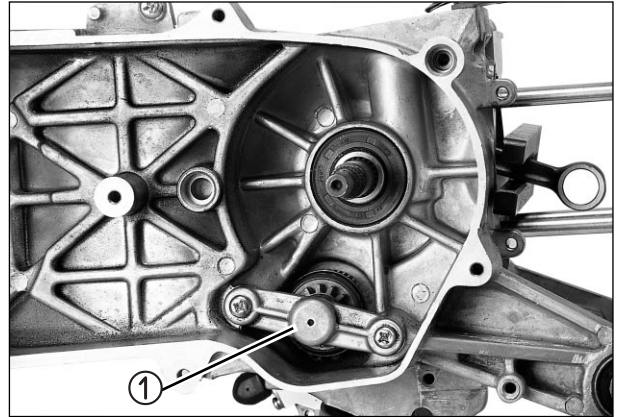

- Install the starter driven gear ② over the left crankshaft end.

NOTE :

The convex side of hub should face outside when installed in proper position.

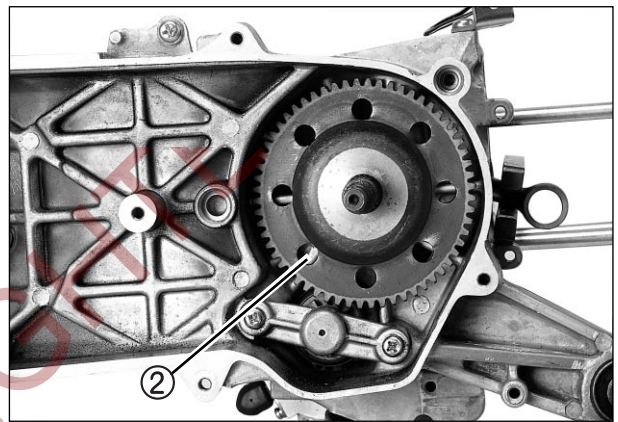

- Install the new O-ring ③.

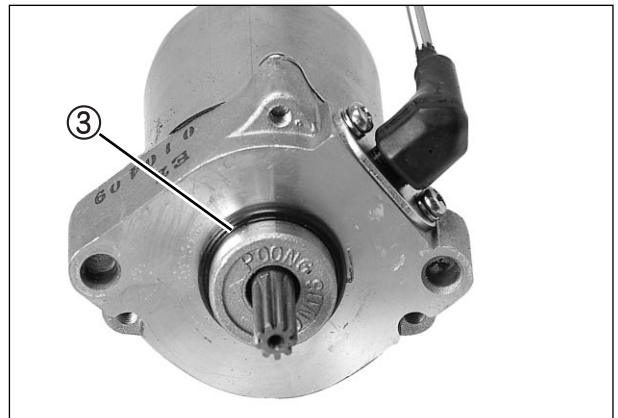

- Install the starter motor ④.

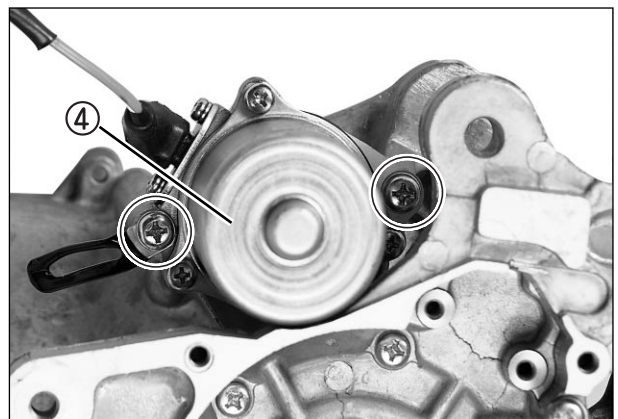

MOVABLE DRIVEN AND CLUTCH

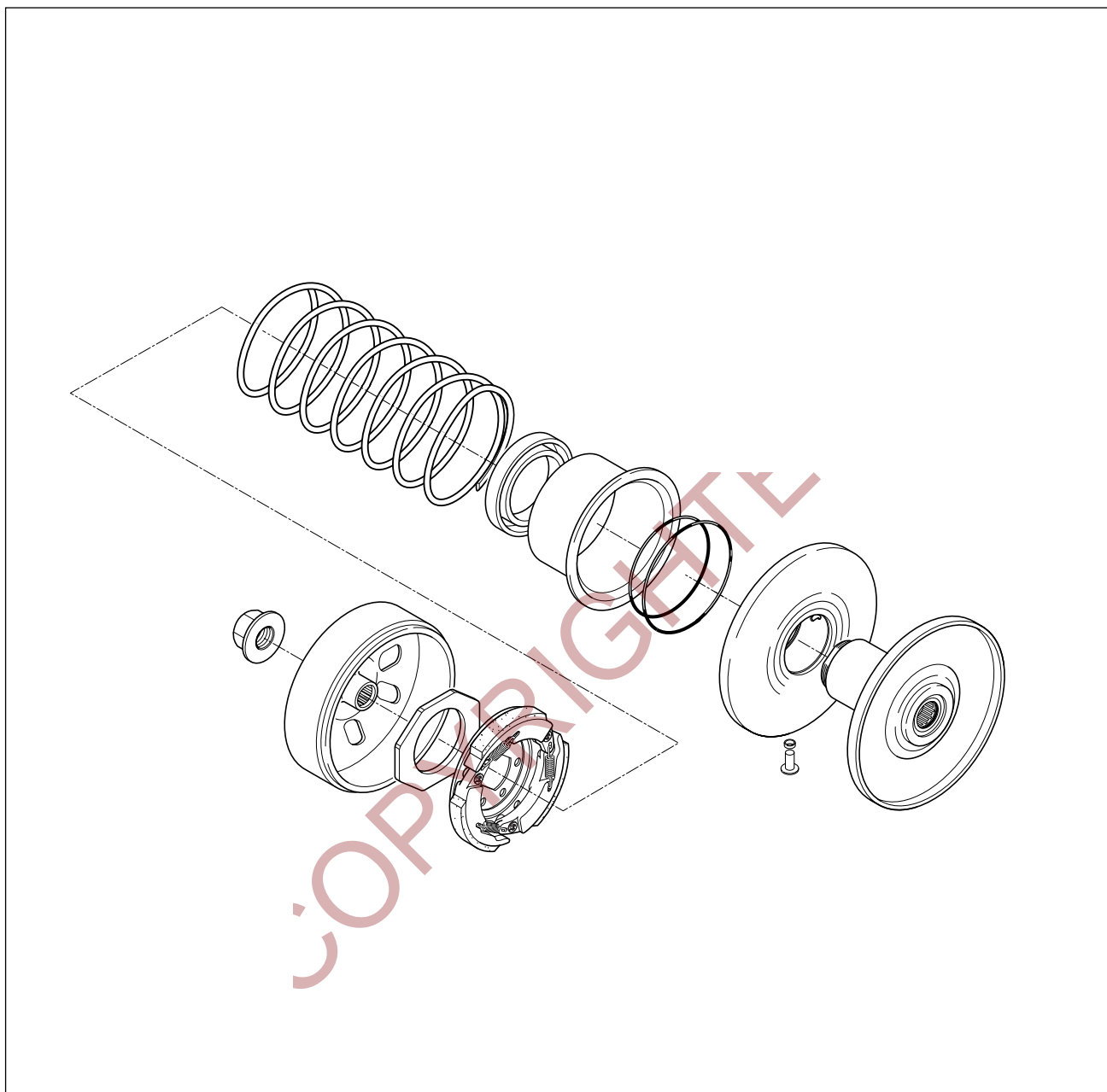

- Install the bearing ② in the fixed driven face ① with the special tool.

 **Bearing installer : 09943-88211**

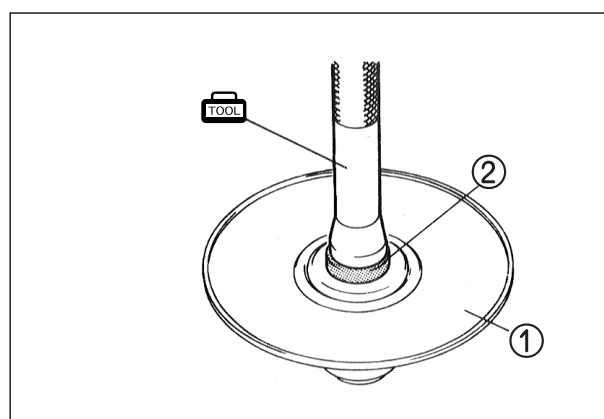

3-33 ENGINE

- Install the circlip ①.

CAUTION

Insert surely in the circlip groove.

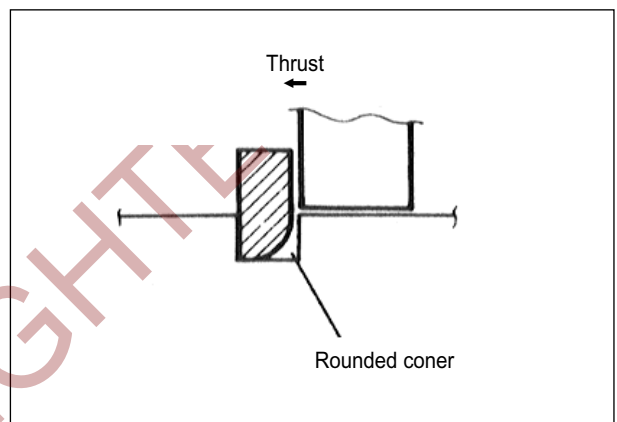
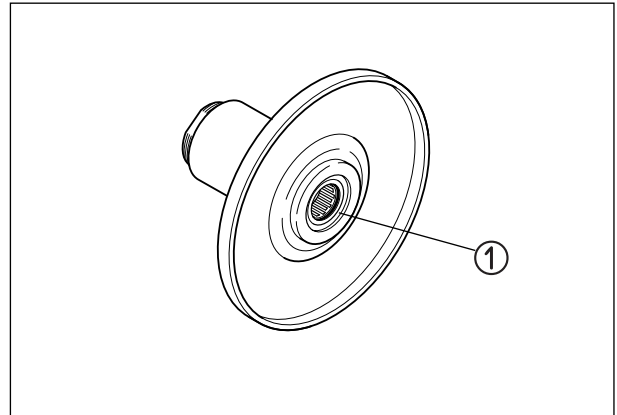

- Install the bearing ② with the special tool.

TOOL Bearing installer : 09943-88211

CAUTION

A mark part of the bearing is pointed to the outside.

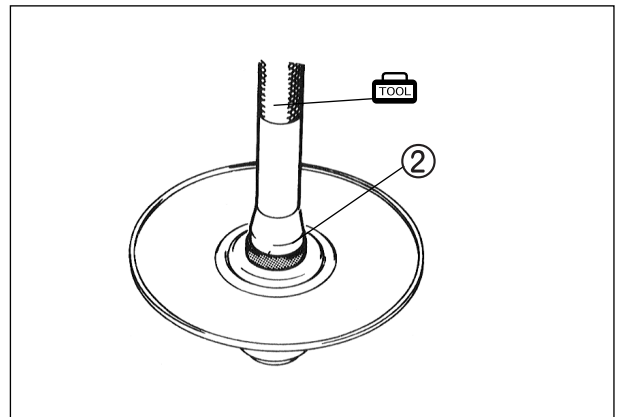

- Install the new O-rings (④, ⑤) to the movable driven face ③ with the special tool.

TOOL Bearing installer : 09913-76010

- Apply **SUPER GREASE "A"** to the groove of movable driven face's inside.

TOOL **SUPER GREASE "A"**

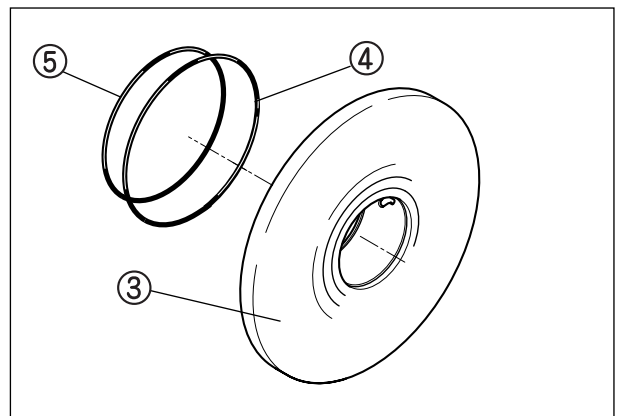

- Install the movable driven face ① to the fixed driven face ②.

CAUTION

When reinstalling the movable driven face to the fixed driven face, make sure that the O-ring is positioned properly.

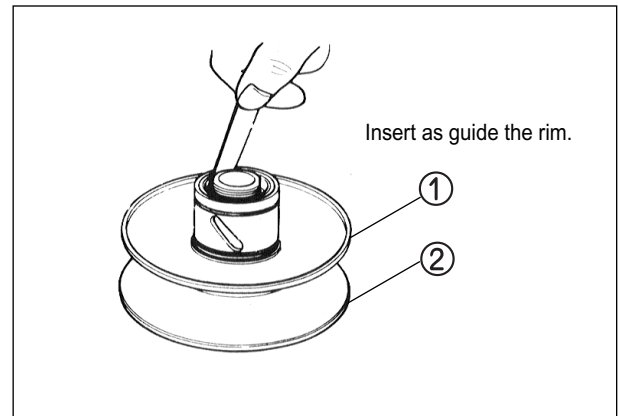

- Install the spacer and pin ③ at three places on the driven face hub.
- Apply **SUPER GREASE "A"** lightly to the cam part where the pins are placed.

SUPER GREASE "A"

- Position the two O-rings ④.

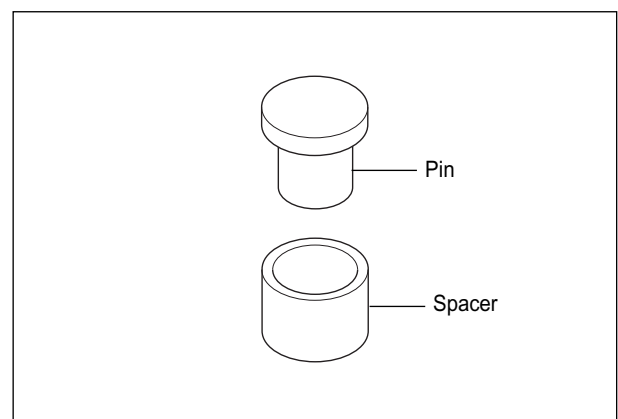
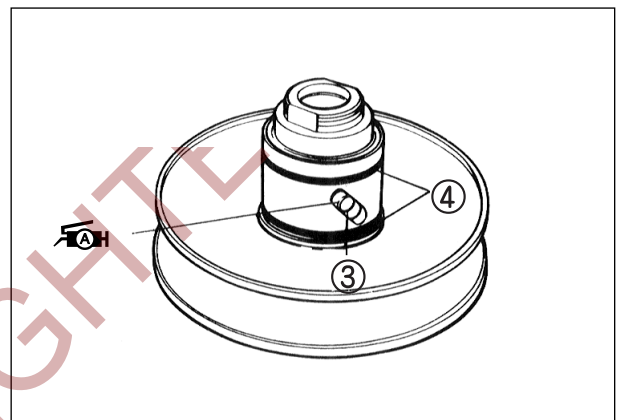

- Install the movable driven face seat ⑤.

CAUTION

The seat is installed rotatable naturally.
The O-ring get damaged, in case of installed by force.

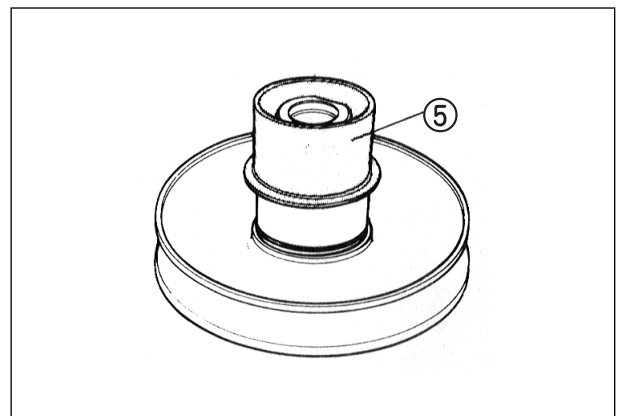

3-35 ENGINE

- Install the spring ①.
- Install the clutch shoe assembly ② and nut ③.

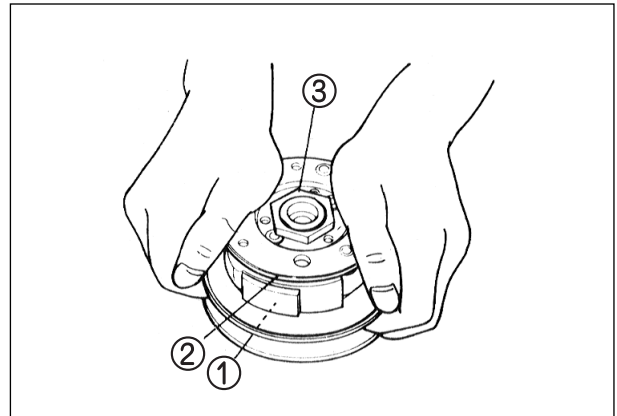

- Tighten the nut to the specified torque with the special tool.

 **Rotor holder : 09930-40113**

 **Clutch shoe nut : 40~60 N·m (4.0~6.0 kg·m)**

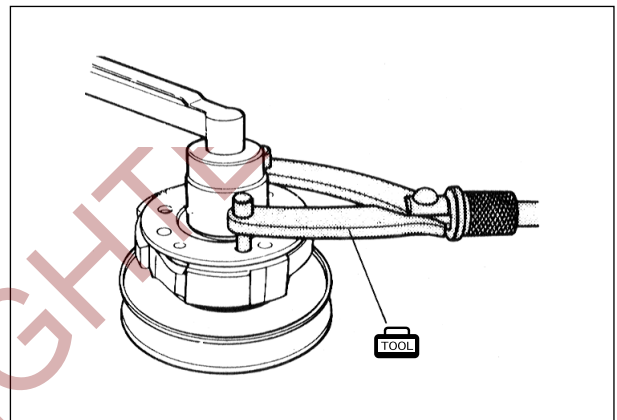

- Insert the V-belt between the driven faces as deep inside as possible while pulling the movable driven face all the way outside to provide the maximum belt clearance.

CAUTION

The V-belt should be positioned so that the arrows on the belt periphery point the normal turning direction. The V-belt contact face on the driven faces should be thoroughly cleaned to be free from oil.

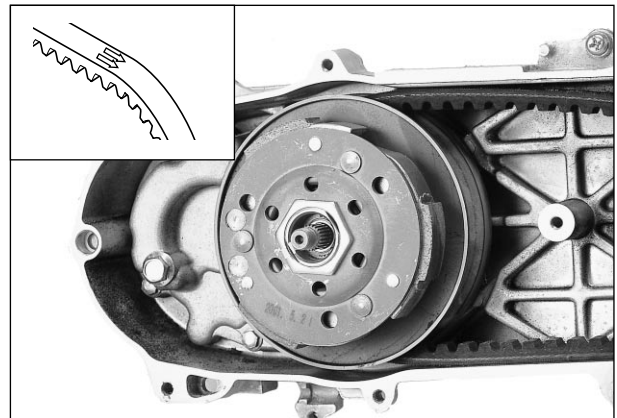

- Thoroughly clean the clutch housing ④ to be free from oil and position it over the clutch shoe assembly.
- Tighten the clutch housing nut ⑤ to the specified torque.

 **Clutch housing nut : 40~60 N·m (4.0~6.0 kg·m)**

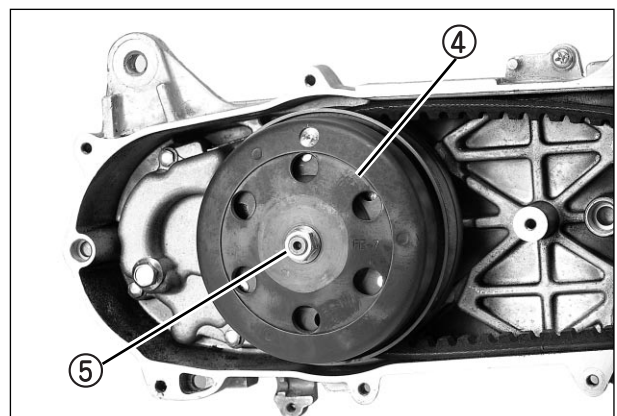

MOVABLE DRIVE

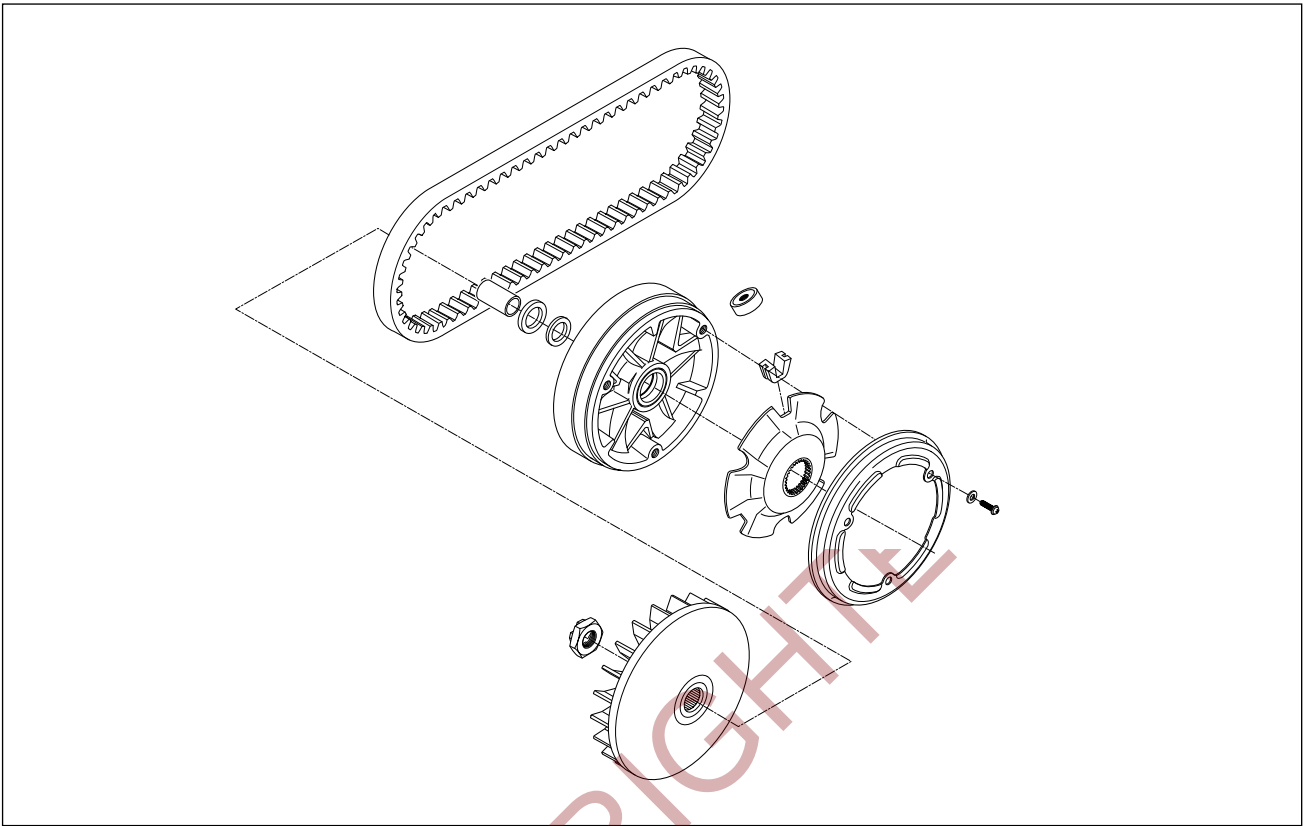

- Install the roller ② at six places to the movable drive face ①.

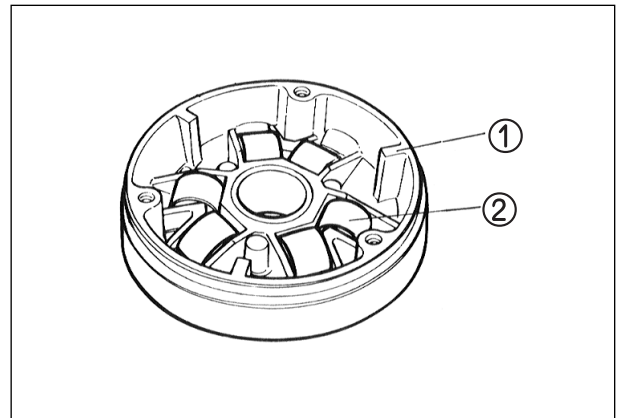

- Mount the three dampers ④ on the movable drive plate ③ and install it on the movable drive face ⑤ .
- Position the O-ring ⑥ on the movable drive face.

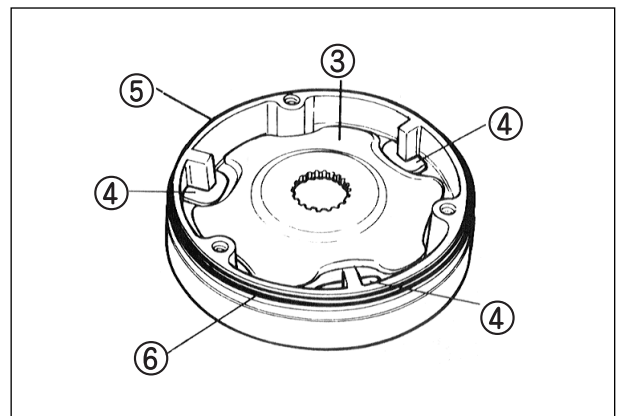

3-37 ENGINE

- Install the movable drive face cover ①.

⚠ CAUTION

Make sure that the movable drive plate is fully positioned inside, or the weight roller may come off.

- Insert the spacer ②.

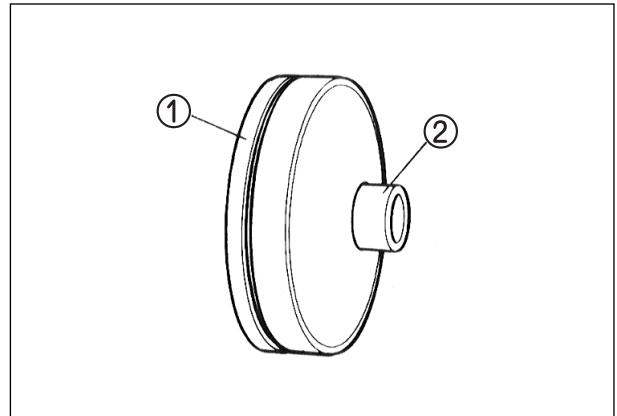

- Position the movable drive face subassembly on the crankshaft as shown in the photo.

⚠ CAUTION

Thoroughly clean the V-belt contact face to be from oil.

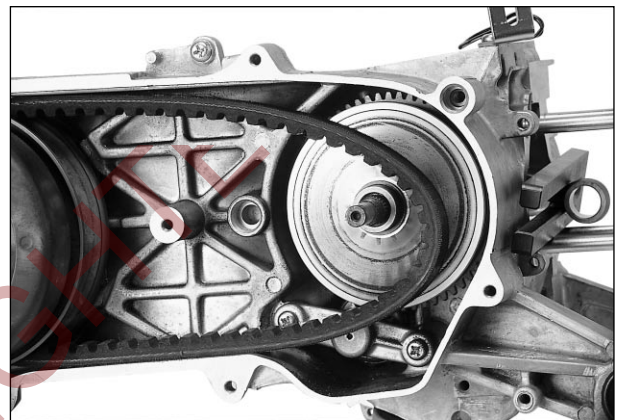

- Install the fixed drive face ③ .
- Tighten the fixed drive face nut ④ to the specified torque with the special tool.

TOOL Conrod holder : 09910-20115

U Fixed drive face nut : 40~60 N·m (4.0~6.0 kg·m)

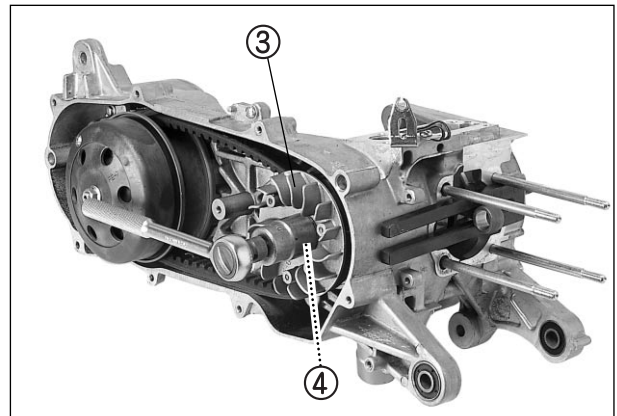

- Continue turning the fixed drive face ⑤ by hand until the V-belt is seated in and both the drive and driven faces ⑥ will move together smoothly without slip.
- Fill the final gear box with transmission oil up to the level hole.

Transmission oil capacity	Replace	80 ml
	Overhaul	90 ml

- Tighten the oil level bolt ⑦ to the specified torque.

U Transmission oil level bolt : 4~7 N·m (0.4~0.7 kg·m)

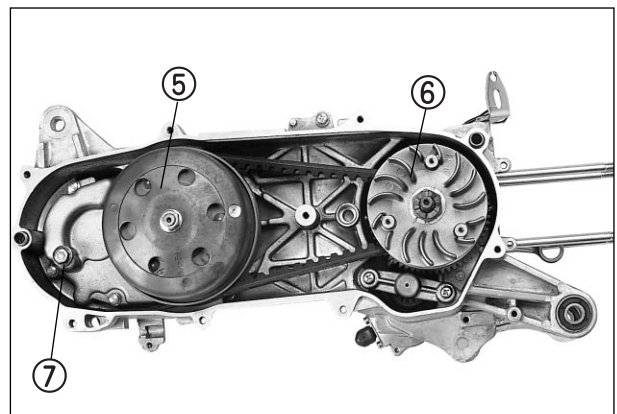

MAGNETO

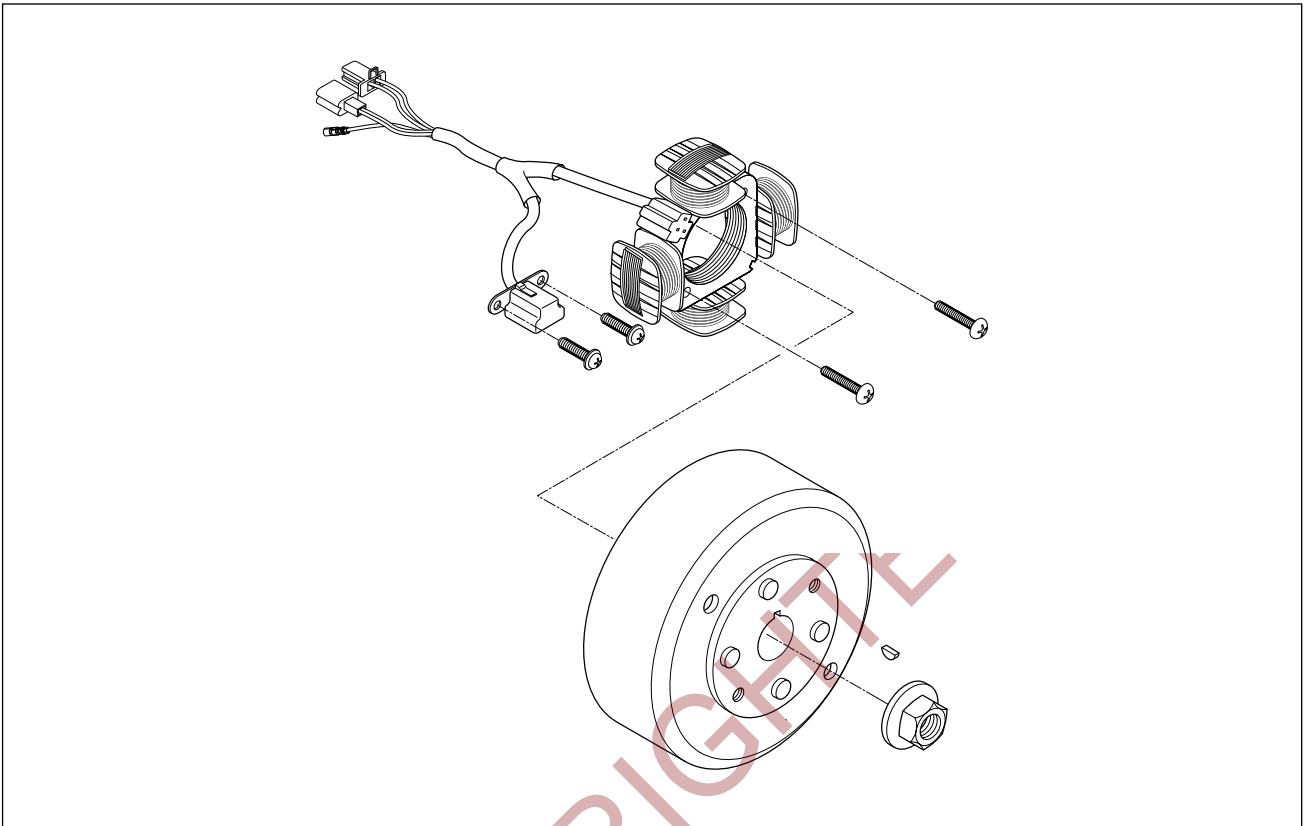

- Degrease the tapered portion of the crankshaft and also the magneto rotor.
- Install the stator ①.
- Install the key ②.

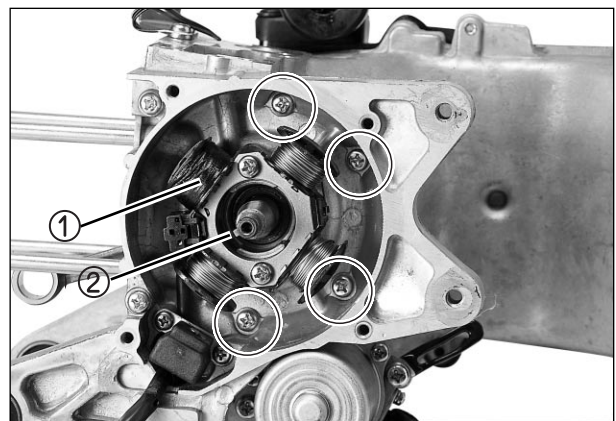

- Install the rotor ③ .
- Apply **THREAD LOCK "1324"** to the rotor nut ④ and tighten it to the specified torque with the special tool.

 **THREAD LOCK "1324"**

 **Conrod holder : 09910-20115**

 **Magneto rotor nut**
: 35~45 N · m (3.5~4.5 kg · m)

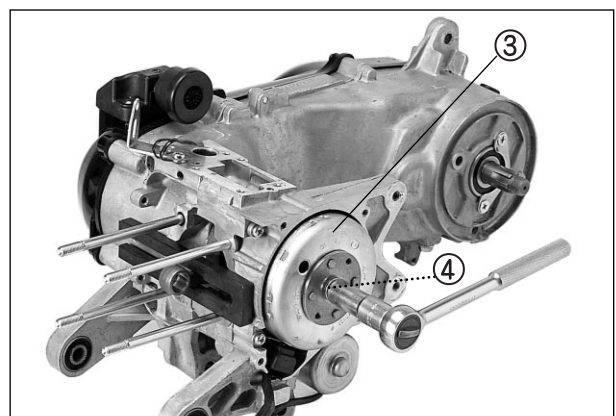

- Apply engine oil on the piston pin and install the piston to the conrod.

⚠ CAUTION

The arrow mark **Ⓐ** on the piston head should point the exhaust side.

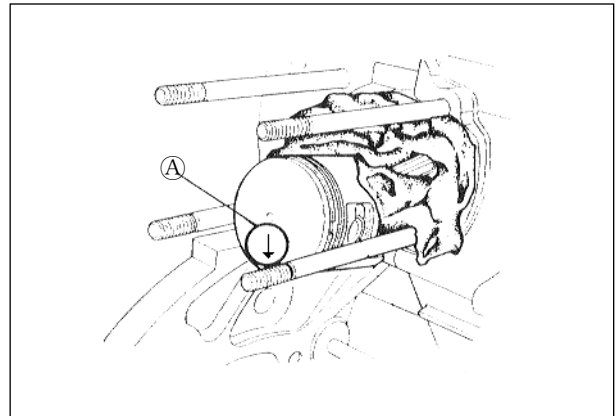

- The circlip should be mounted in such a position that the mating ends of the circlip do not coincide with the groove portion of the piston.
- Position the cylinder base gasket.
- Apply engine oil on the piston and cylinder wall surfaces and install the cylinder over the piston carefully.
- Install the cylinder head gasket and cylinder head.

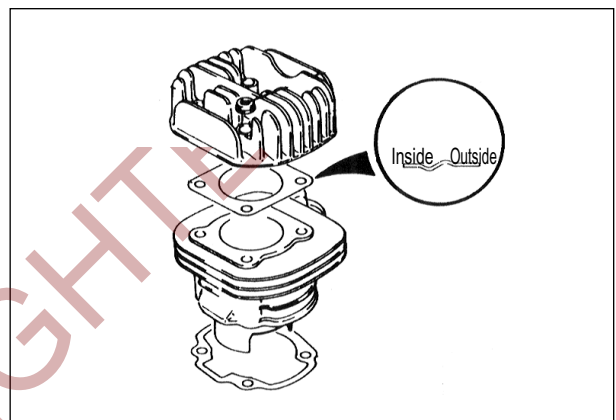

- Tighten the cylinder head nut to the specification, and tighten it diagonally several times as shown in the illustration.

🔧 Cylinder head nut
: 18~28 N·m (1.8~2.8 kg·m)

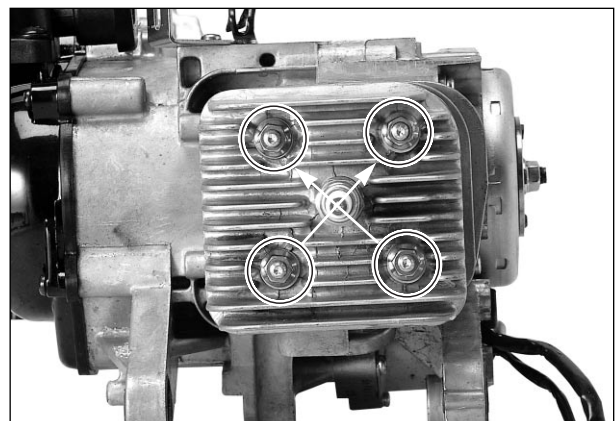

OIL PUMP AND INTAKE PIPE

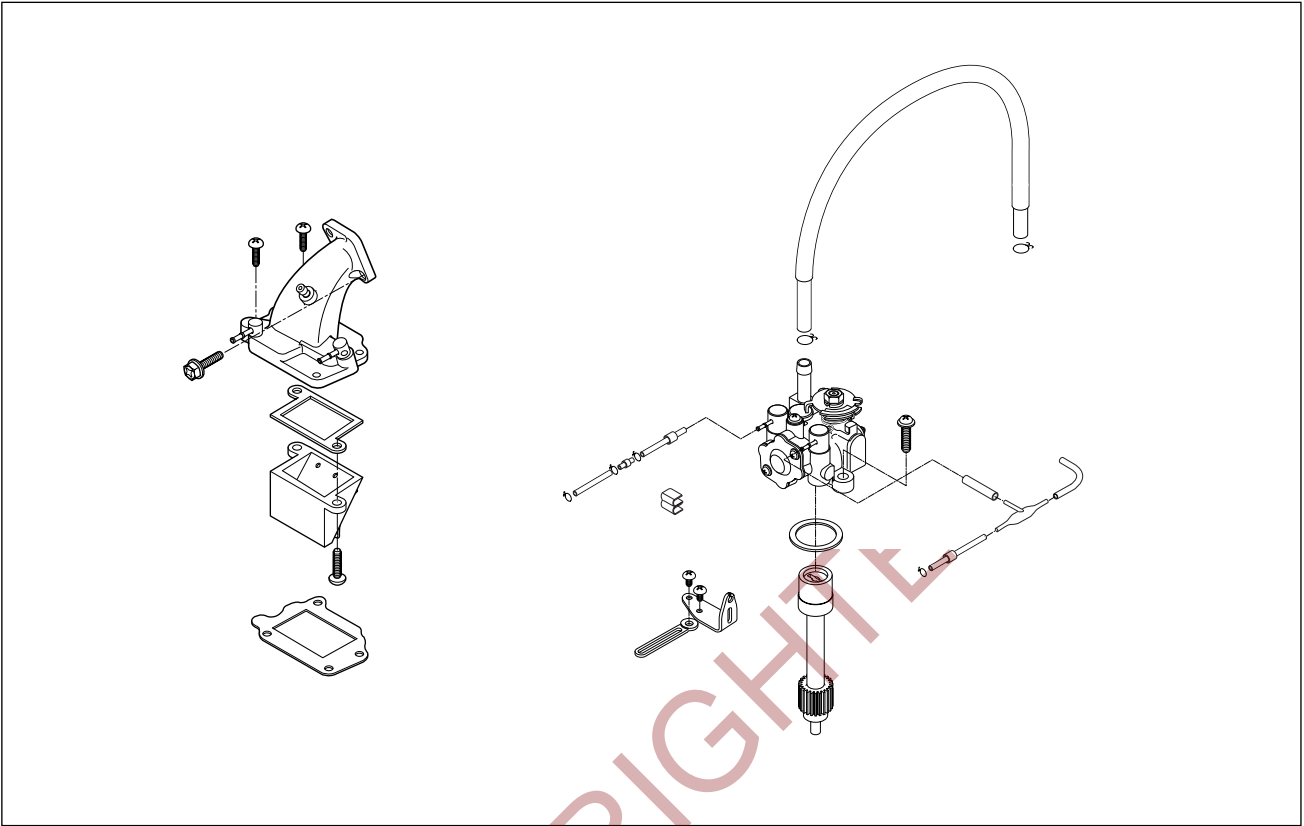

- Apply **SUPER GREASE "A"** to the oil pump driven gear ① and install it to the crankcase.

 **SUPER GREASE "A"**

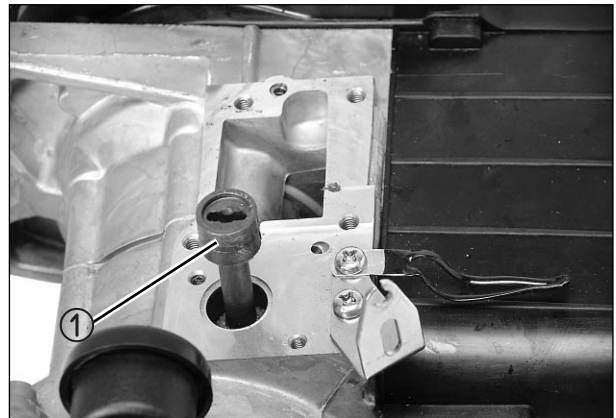

- Install the oil pump ② and tighten it to the specified torque.

 Oil pump bolt : 3~5 N · m (0.3~0.5 kg · m)

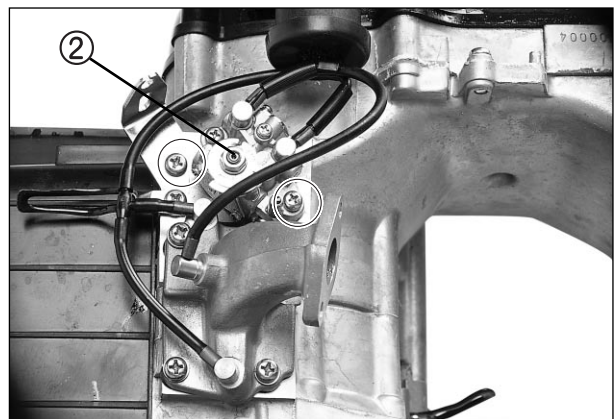

- Install the reed valve gasket ①, intake pipe gasket ② and intake pipe ④ with reed valve ③ to the crankcase.

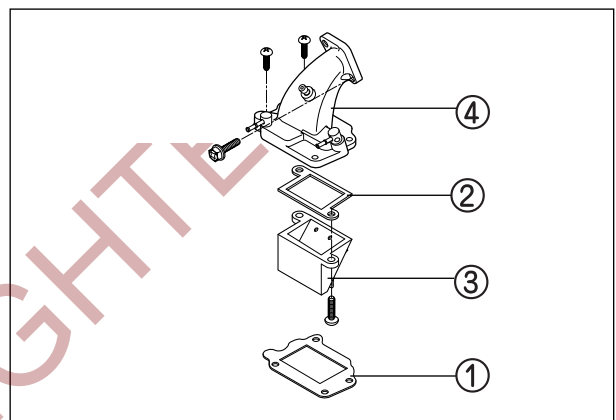
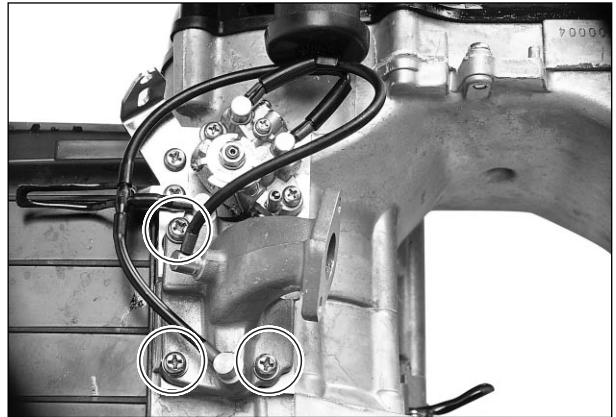

COOLING FAN

- Install the cylinder cowling ⑤.

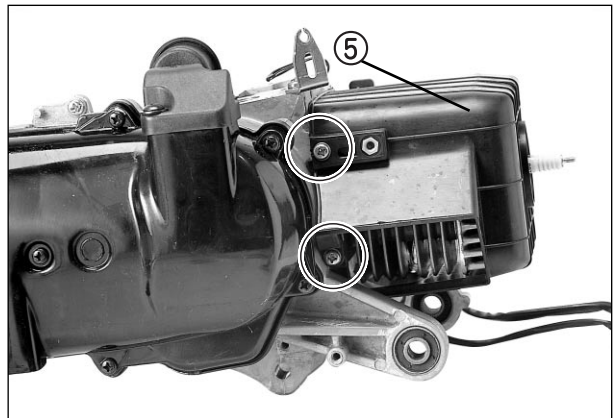

- Install the fan case ⑥.
- Install the magneto lead wire and starter motor lead wire.

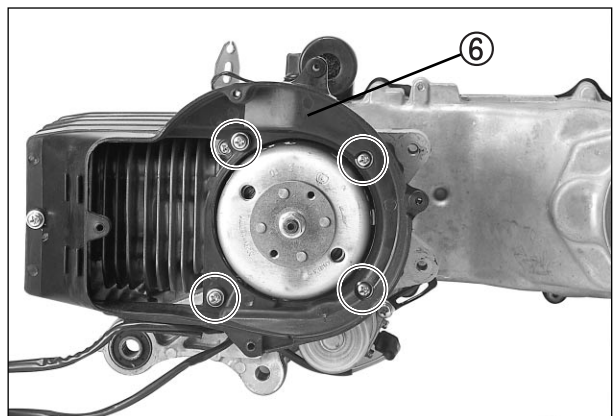

3-43 ENGINE

- Install the cooling fan ①.

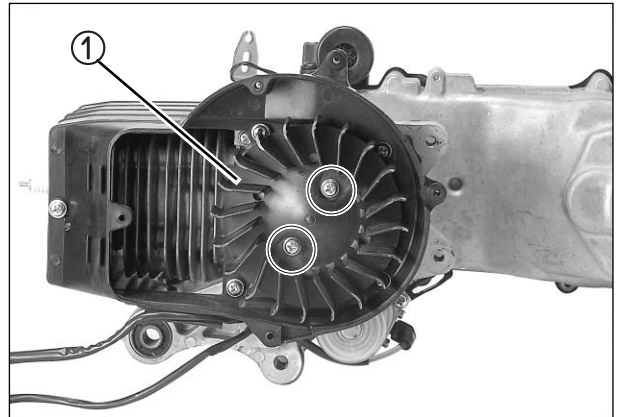

- Install the cooling fan cover ②.

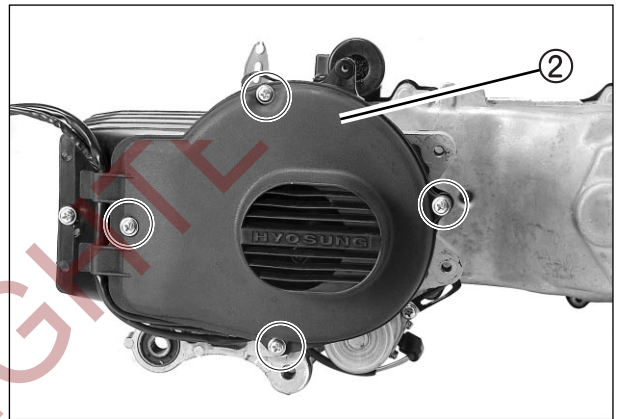

MUFFLER

- Tighten the exhaust pipe bolts ③ and muffler mounting bolts ④ to the specified torque.

- ☑ Exhaust pipe bolt
: 8~12 N · m (0.8~1.2 kg · m)
- Muffler mounting bolt
: 18~28 N · m (1.8~2.8 kg · m)

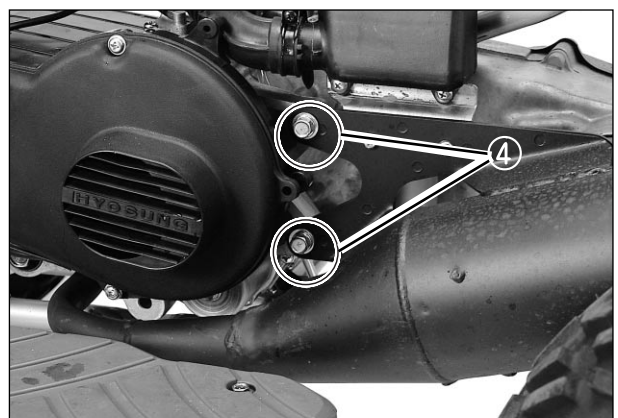
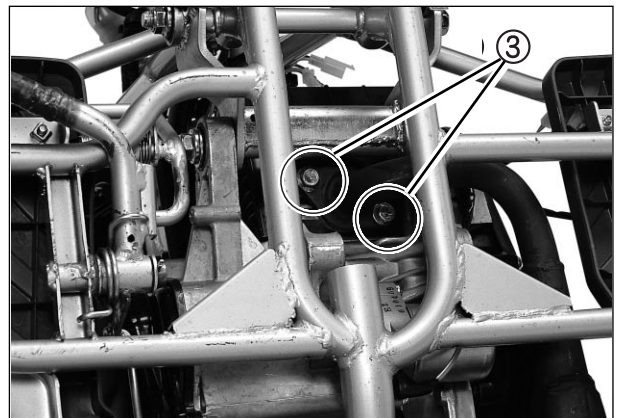

FUEL SYSTEM

CONTENTS

CARBURETOR	4- 1
REMOVAL	4- 1
DISASSEMBLY	4- 2
INSPECTION	4- 4
REASSEMBLY AND REMOUNTING	4- 5
FUEL TANK	4- 7
REMOVAL	4- 7
INSPECTION	4- 7
REMOUNTING	4- 8
OIL PUMP	4- 8

CARBURETOR

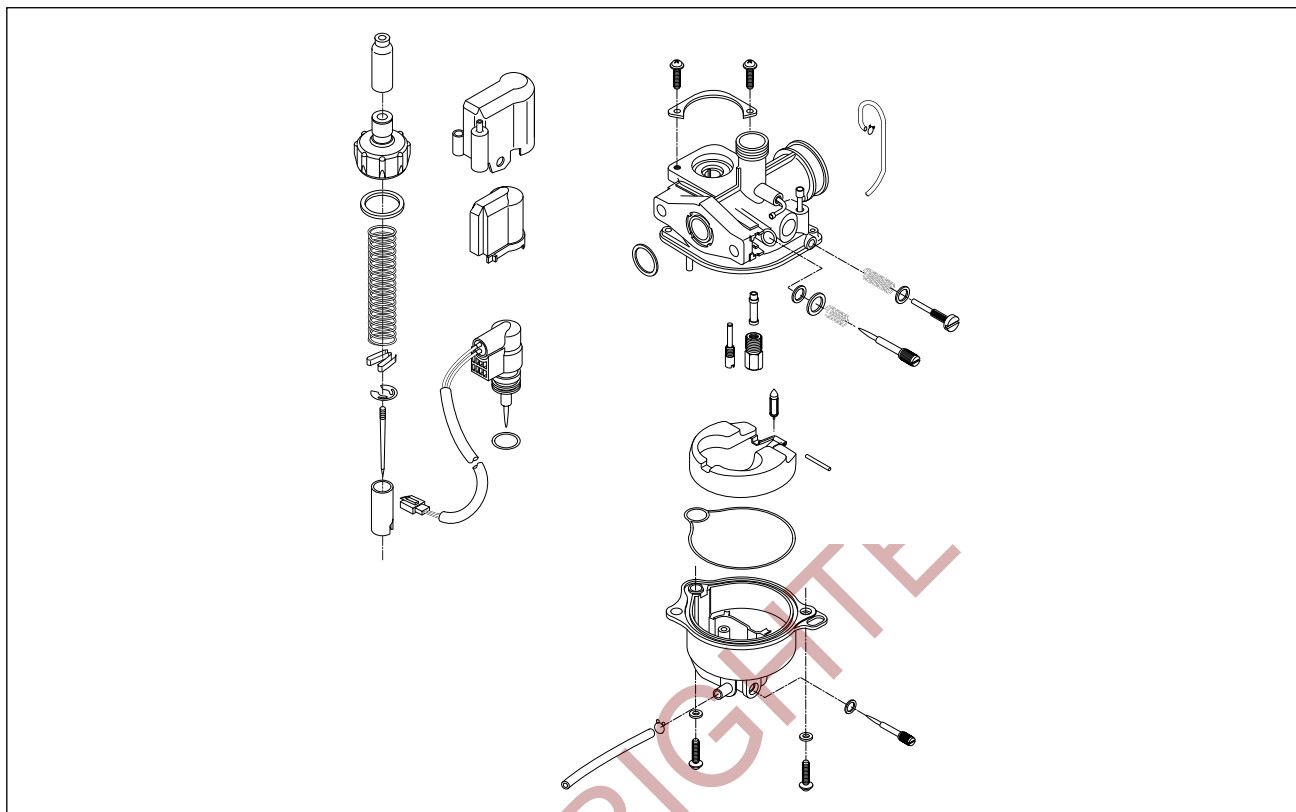

REMOVAL

- Remove the front and rear fender.

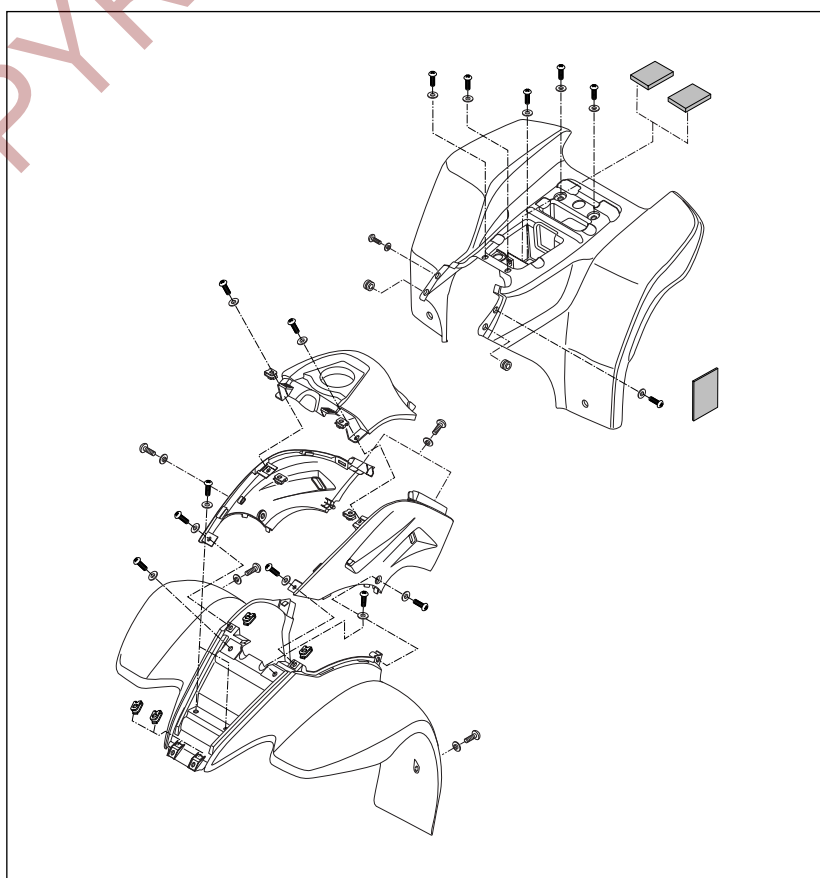

- Remove the carburetor top cap ①, and disconnect the throttle cable ②.
- Disconnect the fuel hose ③.

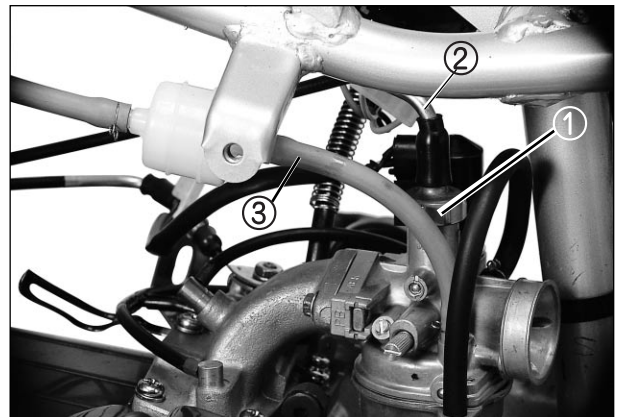

- Remove the carburetor by loosening the mounting bolts ④ .

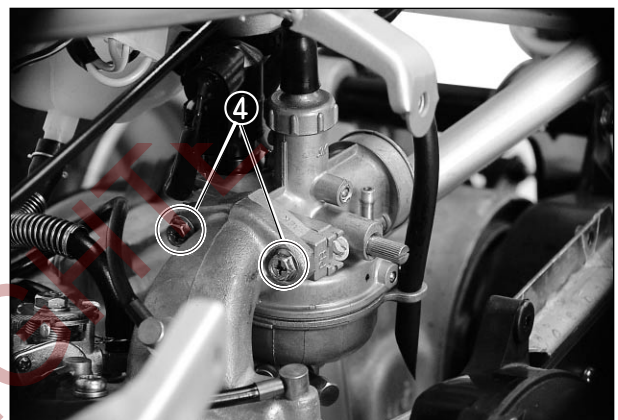

DISASSEMBLY

- Remove the thermoelement assembly.



⚠ CAUTION

Do not attempt to disassemble the thermoelement assembly.
It is not serviceable.



4-3 FUEL SYSTEM

- Remove the throttle valve, spring and jet needle.

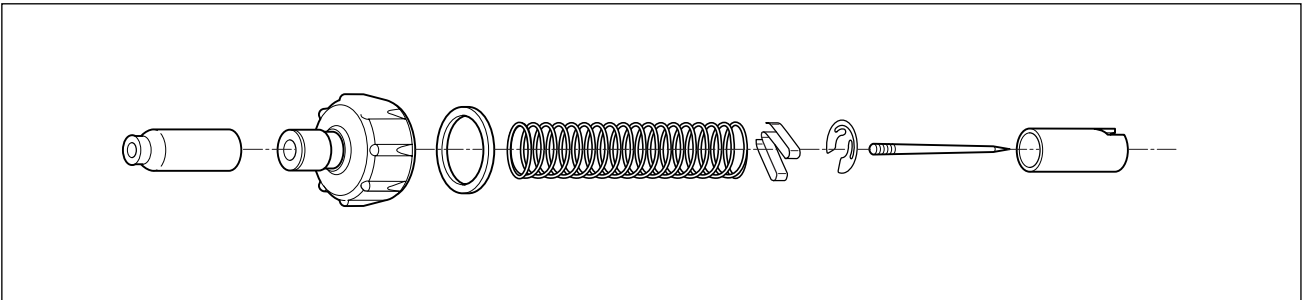

- Remove the float chamber ①.

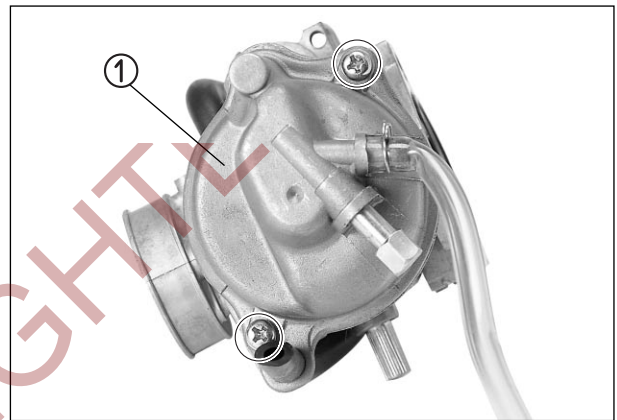

- Pull out the float pin ② and remove the float ③.

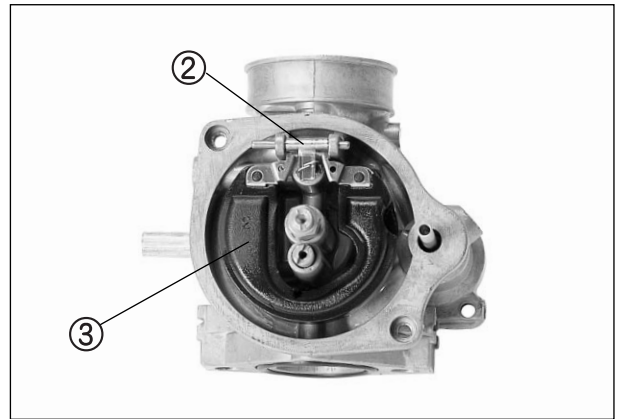

- Remove the needle valve ④.

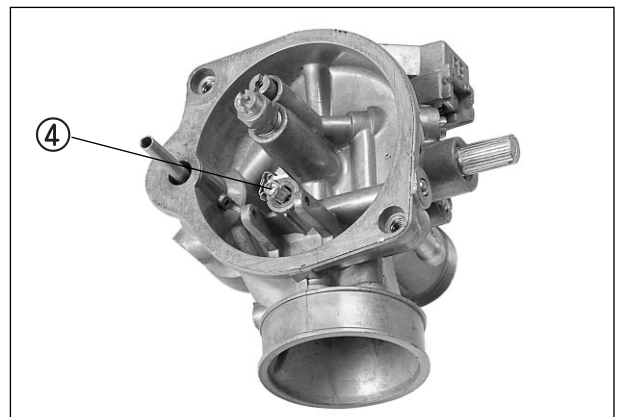

- Remove the throttle stop screw ① and pilot air screw ② .

CAUTION

When removing the pilot air screw, record the revolutions until tighten completely.

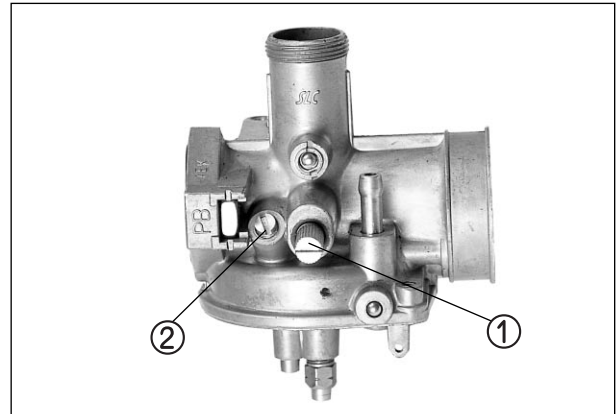
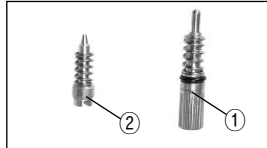

- Remove the pilot jet ③, main jet ④ and needle jet ⑤.

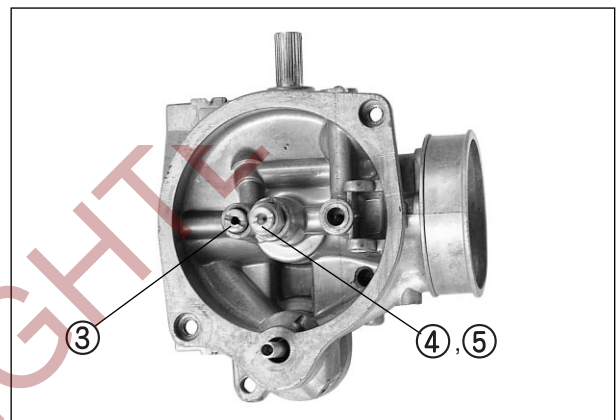
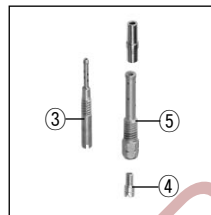

INSPECTION

Check following items for any damage or clogging.

- Pilot jet
- Main jet
- Pilot air screw
- Needle jet air bleeding hole
- Float
- Gasket
- Pilot outlet and bypass holes

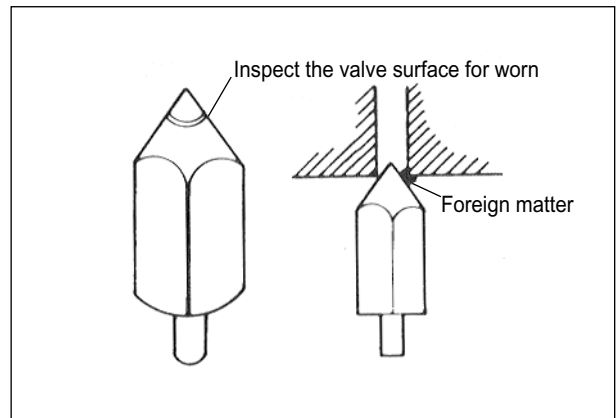

⊙ **NEEDLE VALVE INSPECTION**

If foreign matter is caught between the valve seat and the needle, the gasoline will continue flowing and cause it to overflow. If the seat and needle are worn beyond the permissible limits, similar trouble will occur. Conversely, if the needle sticks, the gasoline will not float chamber. Clean the float chamber and float parts with gasoline. If the needle is worn as shown in the illustration, replace it together with a valve seat. Clean the fuel passage of the mixing chamber with compressed air.



4-5 FUEL SYSTEM

REASSEMBLY AND REMOUNTING

● Reassemble following items.

- ① Pilot air screw
- ② Throttle stop screw
- ③ Pilot jet
- ④ Main jet
- ⑤ Needle jet

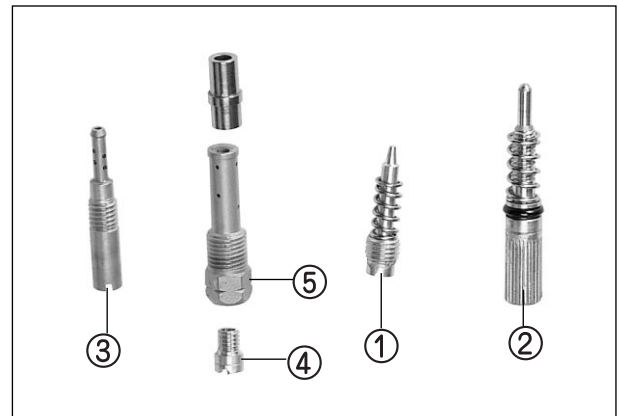

● Install the needle valve ⑥ and float ⑦ on the carburetor body.

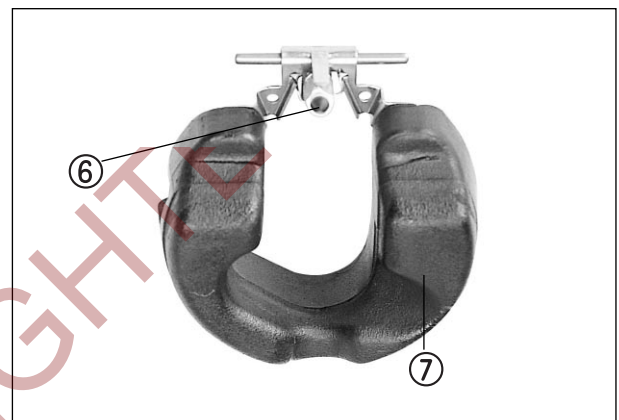

- Insert the float pin ⑧ to the carburetor.
- Install the gasket and float chamber.

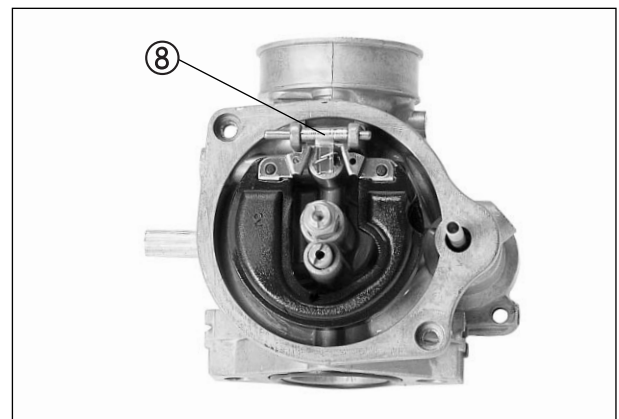

● Install the throttle valve, spring and jet needle.

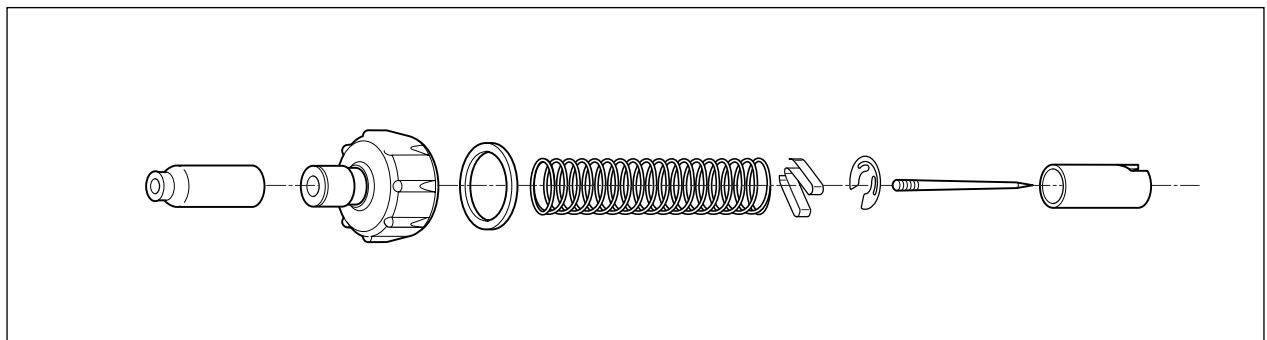

- Install the thermoelement assembly.



- Install the carburetor assembly.

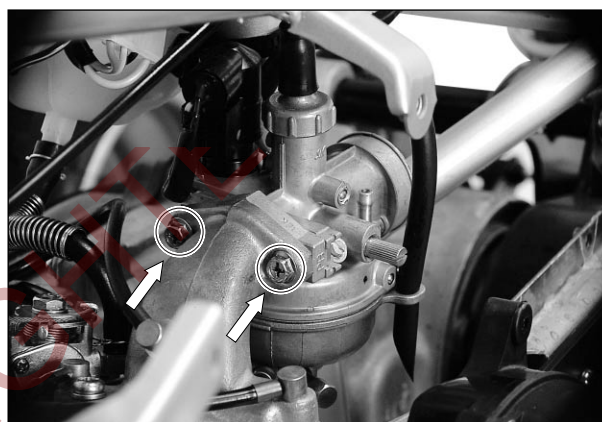

- Install the fuel hose ①.
- Install the carburetor top cap ②.

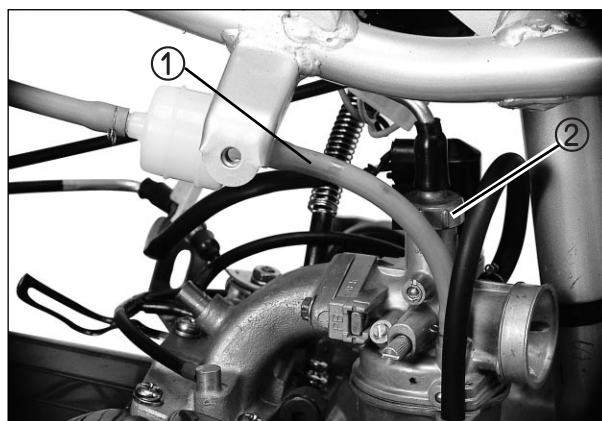

FUEL TANK

REMOVAL

- Remove the frame covers. (Refer to page 4-1)
- Remove the fuel tank mounting bolts.



- Turn the fuel cock to "OFF" and disconnect the fuel hose ①.
- Remove the fuel tank.

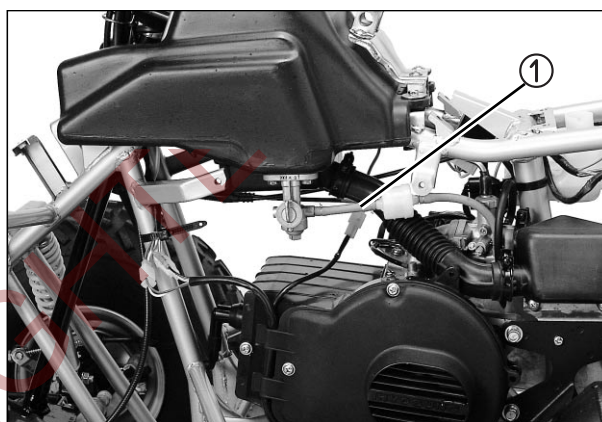
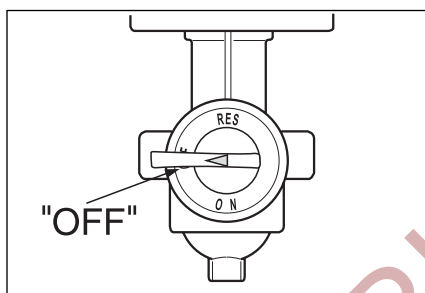

- Remove the fuel cock.



INSPECTION

⊙ FUEL COCK

If the fuel filter is dirty with sediment or rust, fuel will not flow smoothly and loss in engine power may result. Clean the fuel filter with compressed air. Also check the fuel cock for cracks.

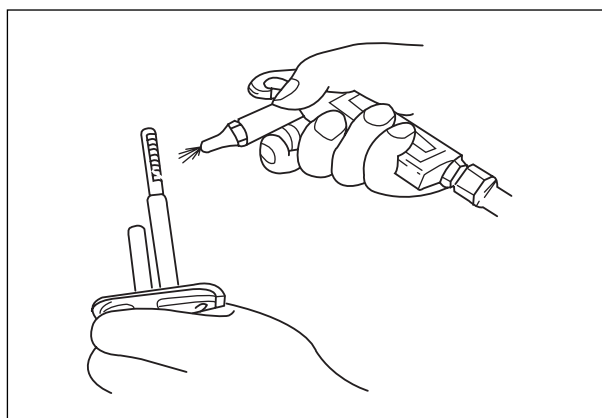

REMountING

Remount the fuel tank and fuel cock in the reverse order of removal.

⚠ WARNING

- ❖ Gaskets ① and ② must be replaced with new ones to prevent fuel leakage.
- ❖ Tighten the fuel cock bolts evenly.

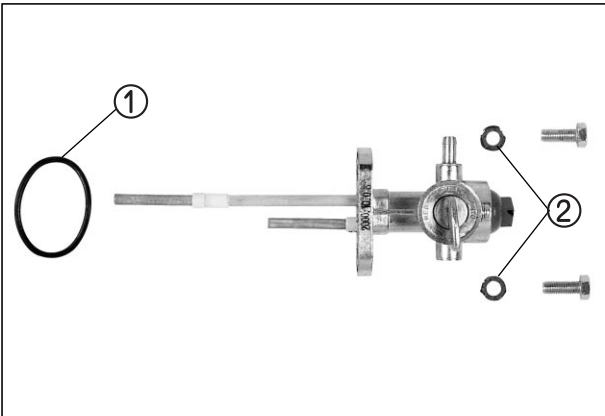

OIL PUMP

⊙ AIR BLEEDING

Whenever evidence is noted of some air having leaked into the oil pipe from the oil tank in a machine brought in for servicing, or if the oil pump has to be removed for servicing, be sure to carry out an air bleeding operating with the oil pump in place before returning the vehicle to the user.

To bleed air, hold the vehicle in standstill condition. Loosen the air bleeding screw ① to let out air and after making sure that the trapped air has all been bled, tighten the air bleeding screw completely.

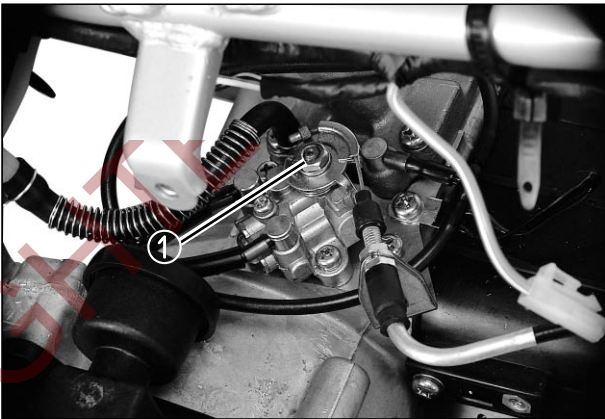

⊙ CHECKING OIL PUMP

Use the special tool, to check the pump for capacity by measuring the amount of oil the pump draws during the specified interval.

- Remove the frame cover.
- Have the HYPOL Oil gauge filled with HYOSUNG HYPOL OIL HS and connect it to the suction side of the pump.
- Run the engine at 3,000 rpm.
- Holding engine speed at the same 3,000 rpm, let the pump draw for 5 minutes. For this operation, the reading taken on the device should be 2.6 ~ 2.8ml.

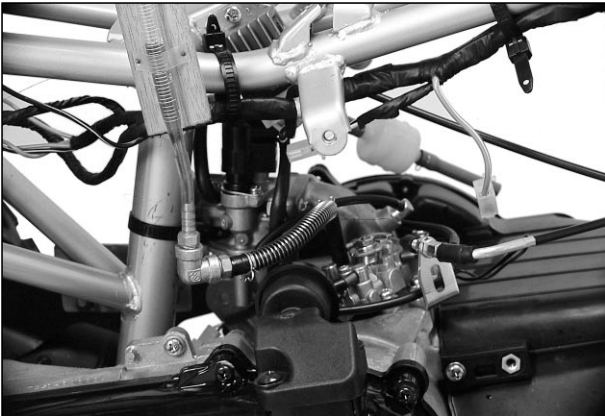

TOOL HYPOL Oil gauge : 09900-21602

Engine oil discharge amount	2.6 ~ 2.8ml (at 3,000 rpm for 5 minutes)
-----------------------------	---

⚠ CAUTION

- During this inspection, strictly follow the following points.
- ❖ Do not touch the rear wheel while running the engine.

COPYRIGHT

ELECTRICAL SYSTEM

CONTENTS

IGNITION/CHARGING SYSTEM	5- 1
IGNITION COIL	5- 1
CDI UNIT	5- 2
STATOR COILS	5- 2
REGULATOR/RECTIFIER	5- 3
STARTER SYSTEM	5- 3
STARTING MOTOR REMOVAL AND DISASSEMBLY	5- 4
STARTING MOTOR INSPECTION	5- 4
STARTER RELAY INSPECTION	5- 5
THERMOELEMENT	5- 5
SWITCHES INSPECTION	5- 6
BATTERY	5- 7

IGNITION/CHARGING SYSTEM

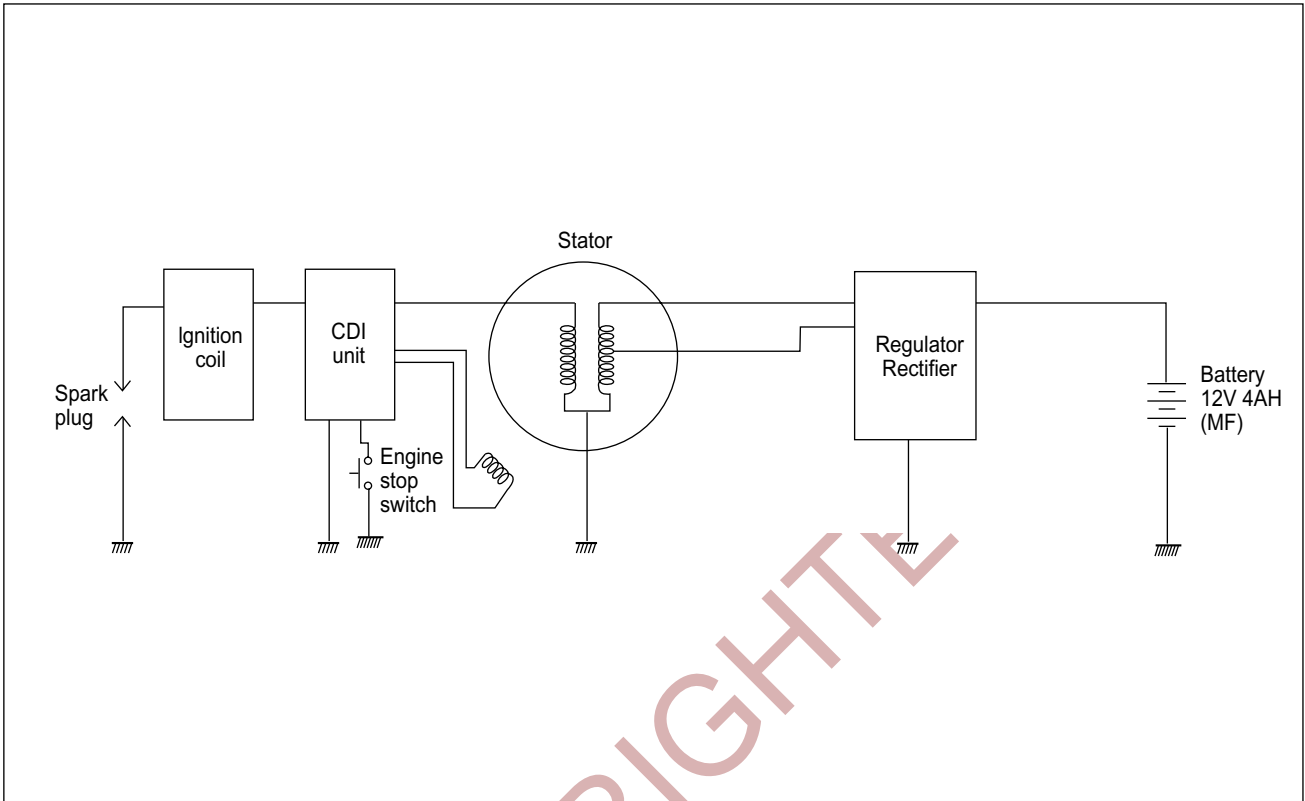

IGNITION COIL

- Pull out the spark plug.
- Place it on the cylinder head after installing it at the plug cap to obtain ground.
- Push in the electric starter switch to rotate the starting motor, test sparking performance.

Spark performance	Over 8 mm (0.3 in)
--------------------------	--------------------

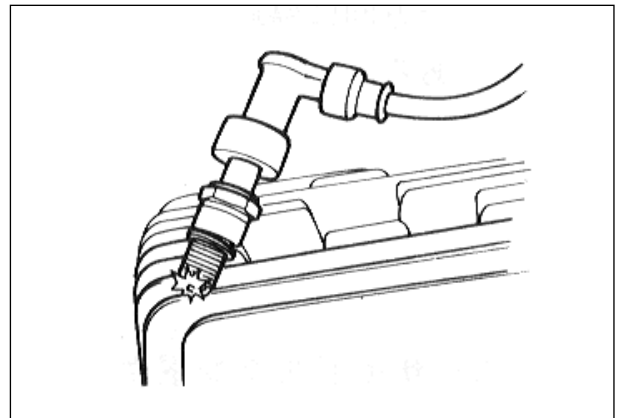

- Check the ignition coil with the pocket tester.

Ignition coil resistance	
Primary	0.19 ~ 0.24 Ω
Secondary	5.4 ~ 6.6 kΩ

 **Pocket tester : 09900-25002**

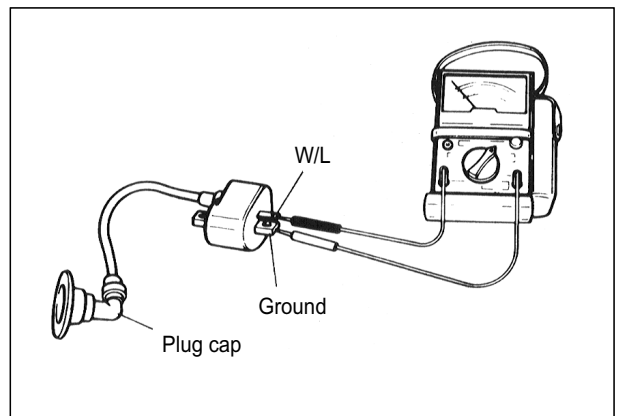

CDI UNIT

Using the pocket tester ($R \times 1k\Omega$ range), measure the resistance between the lead wires in the following table.

Unit : $k\Omega$

		⊕ Probe of tester					
		1	2	3	4	5	6
Probe of tester	⊕ 1		OFF	OFF	OFF	OFF	OFF
	2	14~18		7~9	3~4	7.5~9.5	5.5~6.5
	3	3.6~4.4	OFF		OFF	OFF	OFF
	4	8~10	OFF	3~4		3~4	2~2.5
	5	12.5~15.5	OFF	6~8	27~33		29~35
	⊖ 6	10.5~13.5	OFF	5~7	2~2.5	6~7	

 Pocket tester : 09900-25002

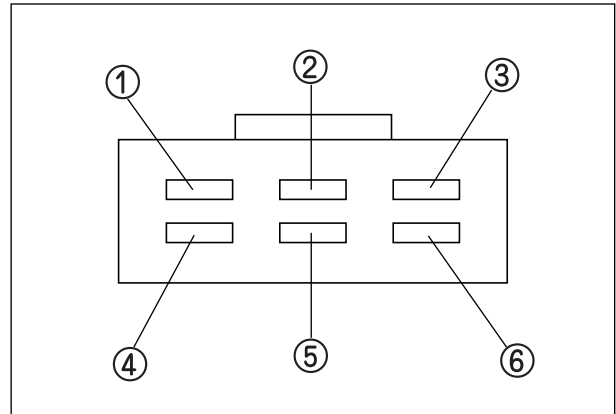

STATOR COILS

- Using the pocket tester, measure the resistance between the lead wire and ground. If the resistance checked is incorrect, replace the coil.

Unit : Ω

Stator coil resistance	Standard	
Lighting coil	0.54 ~ 0.80 Ω	Y/W - Ground
Charging coil	0.69 ~ 1.30 Ω	W/R - Ground
Exciting coil	146 ~ 220 Ω	B/R - Ground
Pick-up coil	90 ~ 110 Ω	Br - W

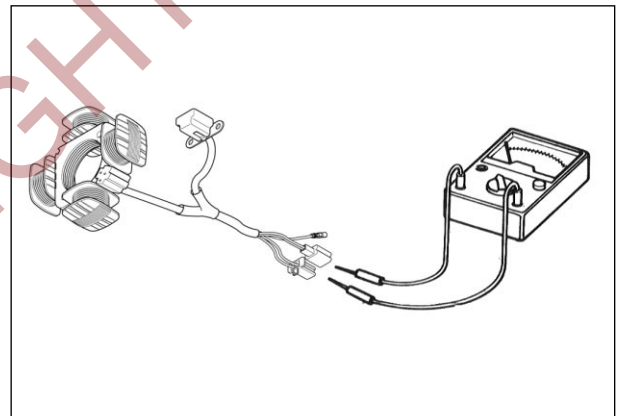

⊙ CHARGING OUTPUT CHECK

Start the engine and keep it running at 5,000 rpm. Measure the DC voltage between the battery terminal ⊕ and ⊖ with a pocket tester.

If the tester reads under or over following specification, check the no-load performance or replace the regulator/rectifier.

CAUTION

When making this test, be sure that the battery is in fully-charged condition.

Standard charging output 13.0 ~ 16.0 V (at 5,000 rpm)

 Pocket tester : 09900-25002
 Engine tachometer : 09900-26006



5-3 ELECTRICAL SYSTEM

⊙ NO-LOAD PERFORMANCE OF A.C. GENERATOR

- Disconnect the magneto lead wire coupler.
- Start the engine and keep it running at 5,000 rpm.
- Using a pocket tester, measure the AC voltage between the three lead wire. If the tester reading is as follows, magneto is in good condition.

Standard no-load performance of A.C. generator	More than 17.0 V (at 5,000 rpm)
---	---------------------------------

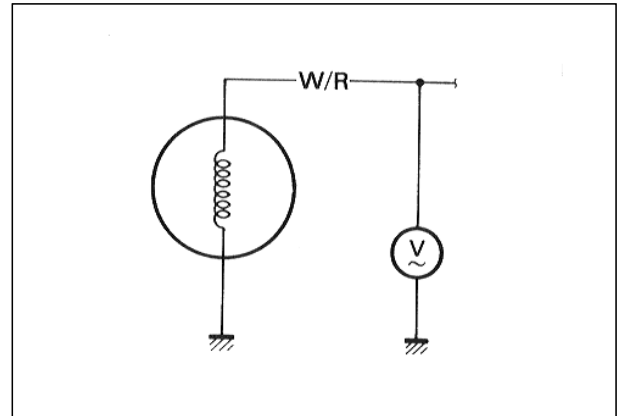

REGULATOR/RECTIFIER

- Disconnect the coupler.
- Using the pocket tester (× 1kΩ Range), measure the resistance between the terminals as shown in the following table. If the resistance checked is incorrect, replace the regulator/rectifier.

Unit : kΩ

		⊕ Probe of tester to:			
		1	2	3	B
⊖ Probe of tester to:	1		50 ~ 260	∞	∞
	2	50 ~ 230		∞	∞
	3	∞	∞		∞
	4	∞	∞	10 ~ 100	

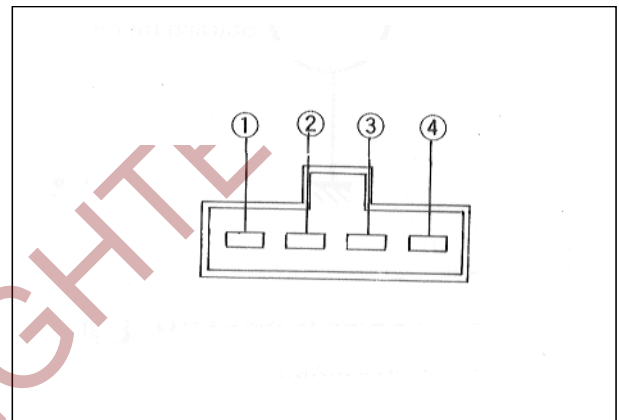

 **Tool** Pocket tester : 09900-25002

STARTER SYSTEM

The starter system is shown in the diagram below : namely, the starting motor, starter relay, starter switch and battery. Depressing the starter switch (on the left handlebar switch box) while squeezing the front or rear brake lever energizes the relay, causing the contact points to close which connects the starting motor to the battery.

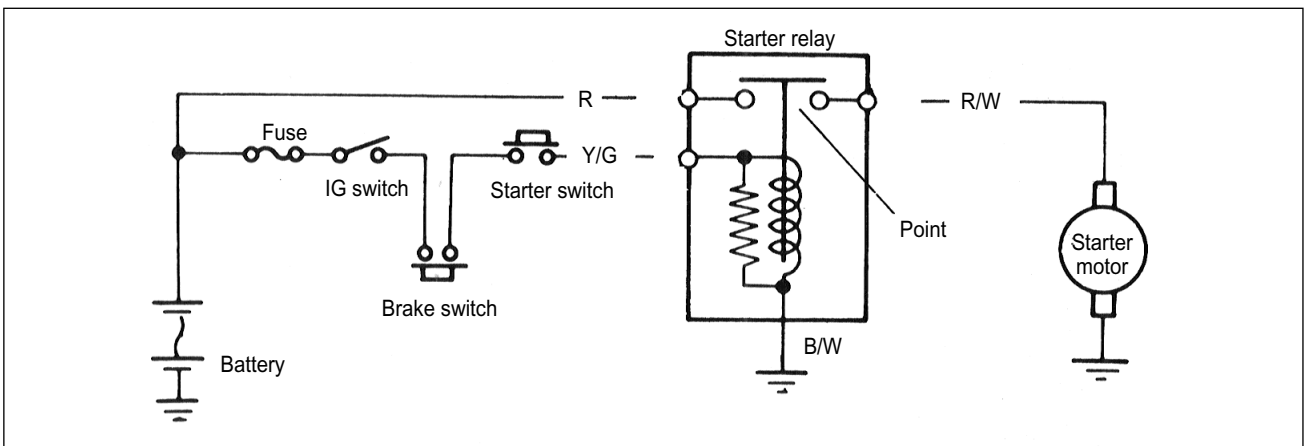

STARTING MOTOR REMOVAL AND DISASSEMBLY

Remove the starting motor.

Disassemble the starting motor as shown in the illustration.

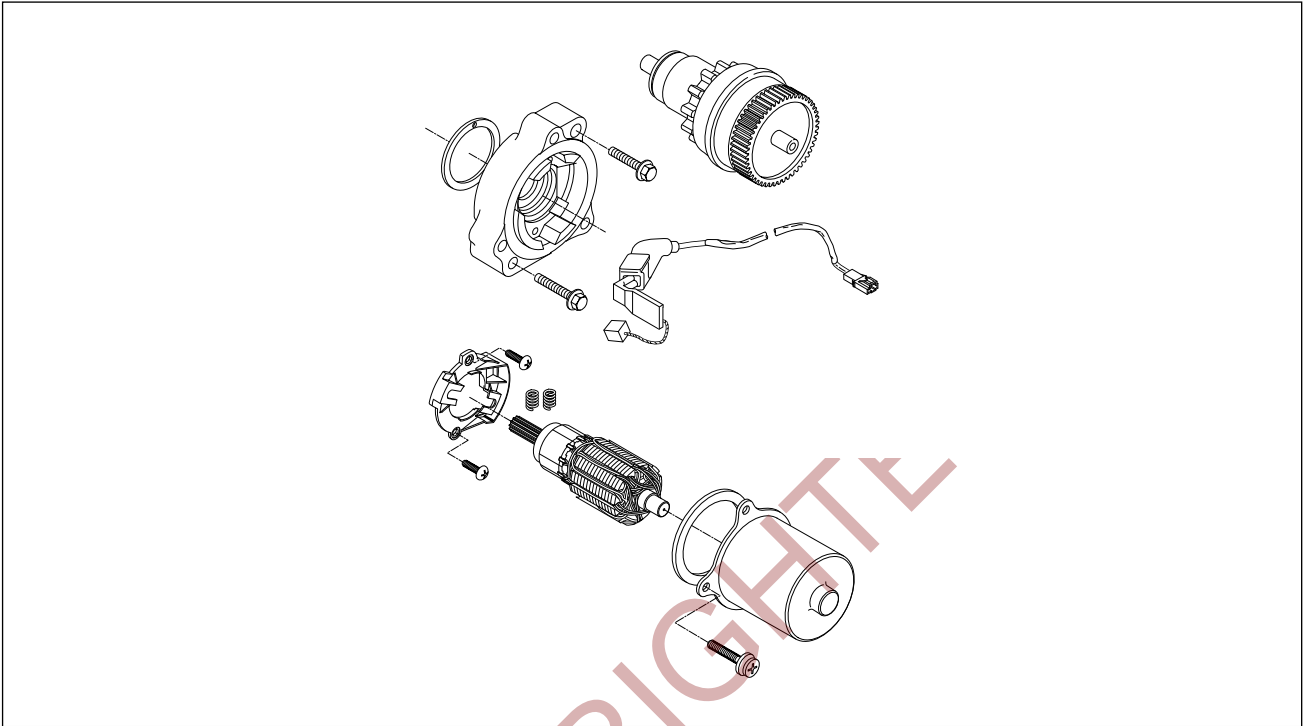

STARTING MOTOR INSPECTION

Ⓢ CARBON BRUSHES

When the brushes are worn, the motor will be unable to procedure sufficient torque, and the engine will be difficult to turn over. To prevent this, periodically inspect the length of the brushes and replace them when they are too short or chipping.

Carbon brushes wear	Service limit
	3.5 mm (0.138 in)

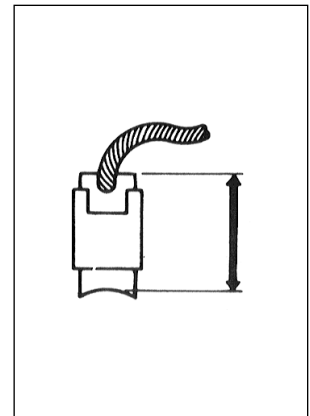
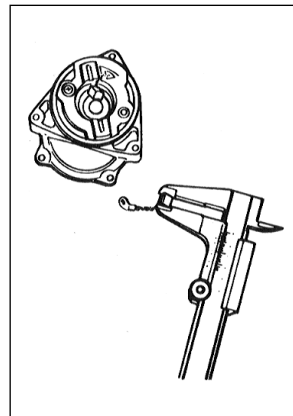

Ⓢ COMMUTATOR

If the commutator surface is dirty, starting performance will decrease. Polish the commutator with #400 or similar fine emery paper when it is dirty. After polishing wipe the commutator with a clean dry cloth. Measure the commutator under cut ①.

Commutator under cut	Service limit
	0.2 mm (0.008 in)

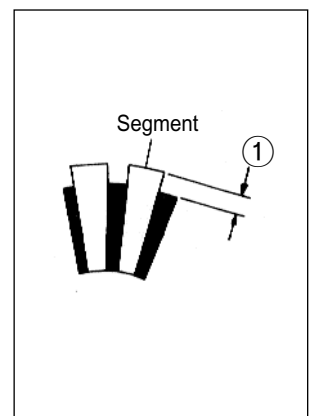
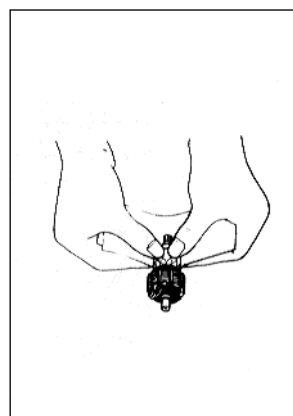

5-5 ELECTRICAL SYSTEM

⊙ ARMATURE COIL

Using the pocket tester, check the coil for open and ground by placing probe pins on each commutator segment and rotor core (to test for ground) and on any two segments at various places (to test for open), with the brushes lifted off the commutator surface.

If the coil is found to be open-circuited or grounded, replace the armature. Continuous use of a defective armature will cause the starting motor to suddenly fail.

 **Pocket tester : 09900-25002**

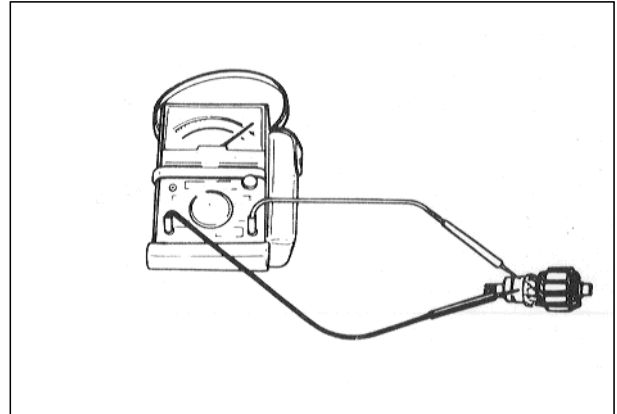

STARTER RELAY INSPECTION

● Disconnect the starter relay lead wire coupler.

Check the coil for “open”, “ground” and ohmic resistance. The coil is in good condition, if the resistance is as follows.

Starter relay standard resistance

Standard 80 ~ 150 Ω

 **Pocket tester : 09900-25002**

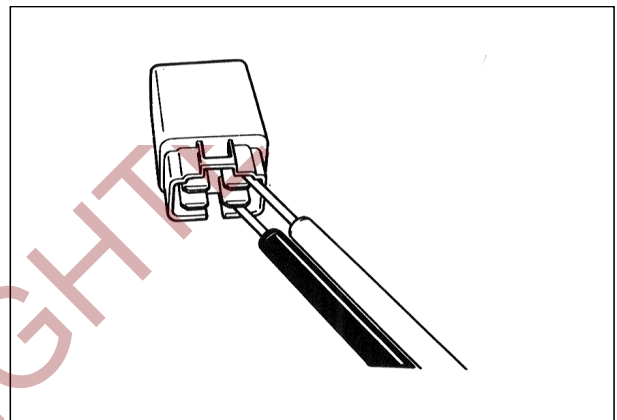

THERMOELEMENT

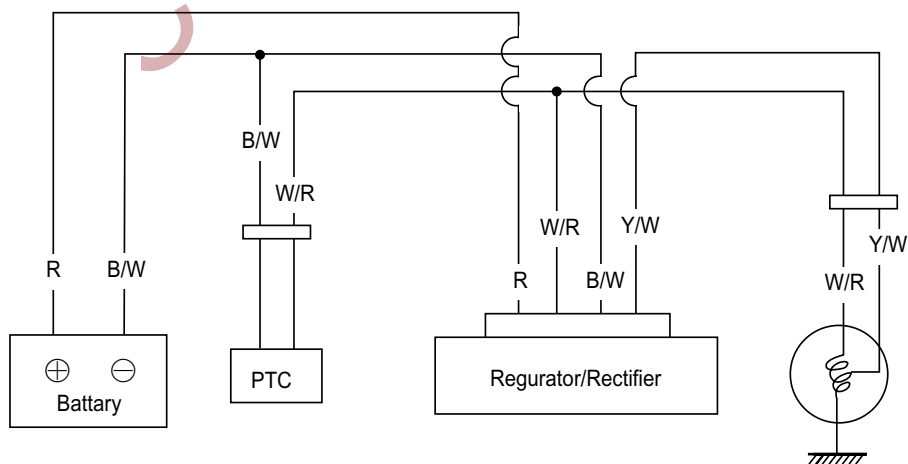

⊙ **INSPECTION**

- Disconnect the thermoelement coupler ①.
- Connect the thermoelement coupler ① to a 12V battery and touch the thermoelement ② to check the temperature being raised.
The thermoelement ② should become heated to a temperature more than that of human body within five minutes. If not, replace with new one.

⚠ CAUTION

This check should be carried out when the carburetor is cold.

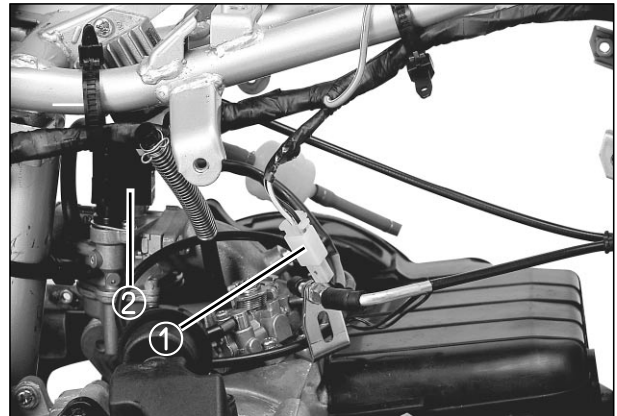

SWITCHES INSPECTION

Inspect each switch for continuity with the pocket tester referring to the chart. If it is found any abnormality, replace the respective switch assembly with new one.

 **Pocket tester : 09900-25002**

WIRE COLOR

- B Black
- L Blue
- G Green
- Gr Gray
- Sb Light blue
- Lg Light green
- O Orange
- R Red
- W White
- Y Yellow
- B/R Black with Red tracer
- B/W Black with White tracer
- W/B White with Black tracer
- Y/W Yellow with White tracer
- Y/G Yellow with Green tracer
- L/W Blue with White tracer

STARTER SWITCH		
	W/B	Y/G
ON	○-----○	○-----○
OFF		

IGNITION SWITCH				
	B/W	B/R	R	O
OFF	○-----○			
ON			○-----○	

ENGINE STOP SWITCH		
	B/R	B/W
⊗	○-----○	○-----○
○		

BATTERY

⦿ CAUTION OF BATTERY TREATMENT

The battery should be well taken care of because it emits flammable gas.

If you don't follow the instruction in the below, there may be an explosion and severe accident.

Therefore, please pay attention to the following points.

- Prohibit positively battery from contacting to short, spark or firearms.
- The recharge of battery should be done in the wide place where the wind is well ventilated.
Please don't recharge it at the sight of wind-proof.

⦿ CAUTION OF BATTERY ELECTROLYTE TREATMENT

- Pay attention for the battery electrolyte not to stain the chassis or the humanbody.
- If it stain the chassis or the humanbody, at once wash a vast quantity of water.
When it is stained, clothes should come into being a hole or painting should take off.
Consult you with a doctor.
- When the battery electrolyte was dropped to the surface of land, wash a vast quantity of water.
Neutralize by hydroxide, bicarbonate of soda and so on.

⦿ CAUTION OF MAINTENANCE FREE BATTERY TREATMENT

- Do not remove the aluminum tape to seal the battery electrolyte filler hole until use as battery of completely seal type.
- Do not use it except the battery electrolyte.
- When pour into the battery electrolyte, necessarily use the electrolyte of the specified capacity.
- Do not open the sealing cap after recharge the battery electrolyte.

● Filling electrolyte.

- ① The battery is put on even land, remove the aluminum tape sealing.
- ② Remove the cap at the electrolyte container.

⚠ CAUTION

Do not remove the seal, not prick with sharp thing.

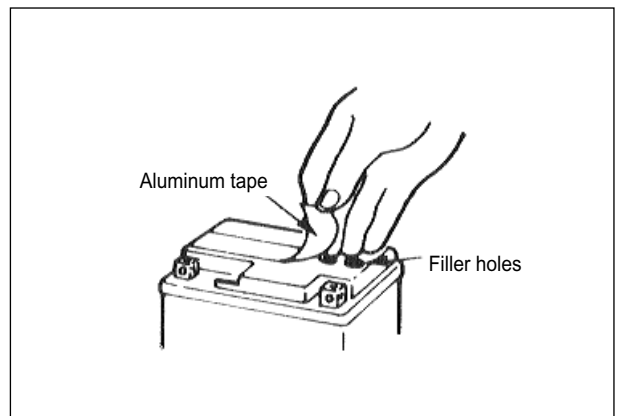
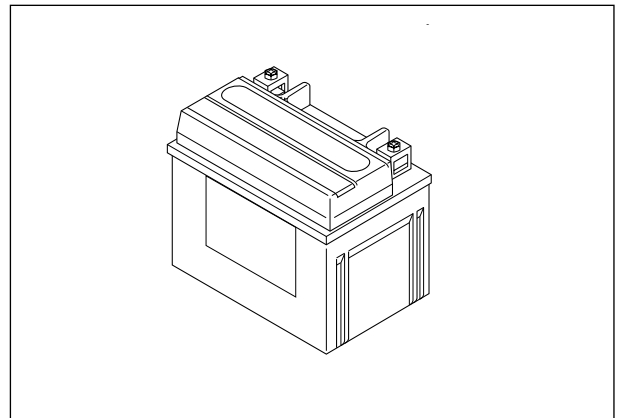

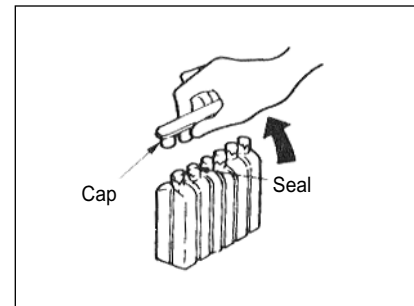
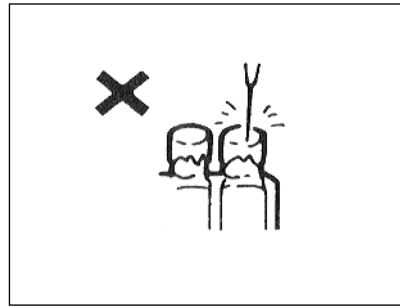
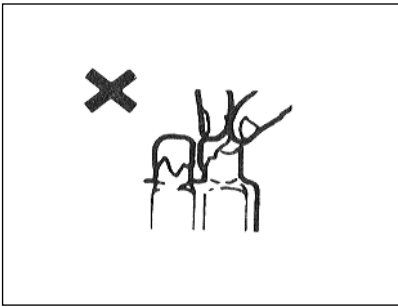

③ Pouring of battery electrolyte

When insert the nozzles of the electrolyte container into the battery's electrolyte filler holes, holding the container firmly so that it does not fall.

Take precaution not to allow any of the fluid to spill.

⚠ CAUTION

There may be a case which can't pour the electrolyte if you put it into electrolyte container slopely.

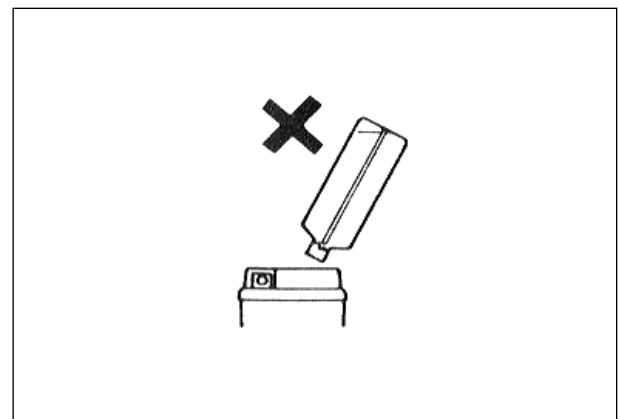
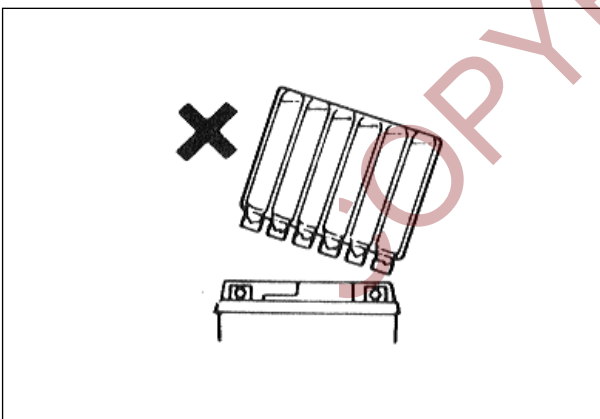
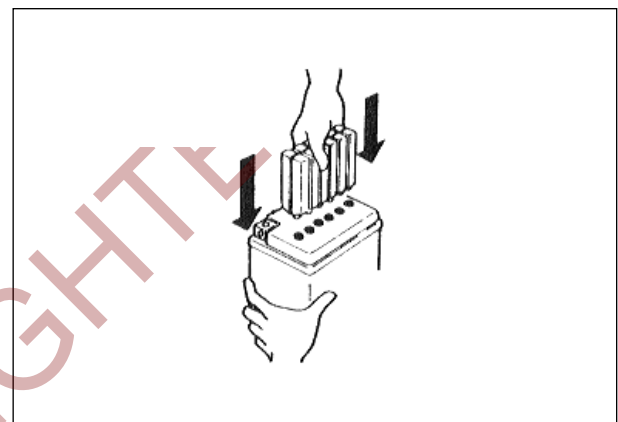

④ Confirmation of pour

Make sure that air bubbles are coming up each electrolyte container, and keep this position for about more than 20 minutes.

⚠ CAUTION

If no air bubbles are coming up from a filler port, tap the bottom of the two or three times.

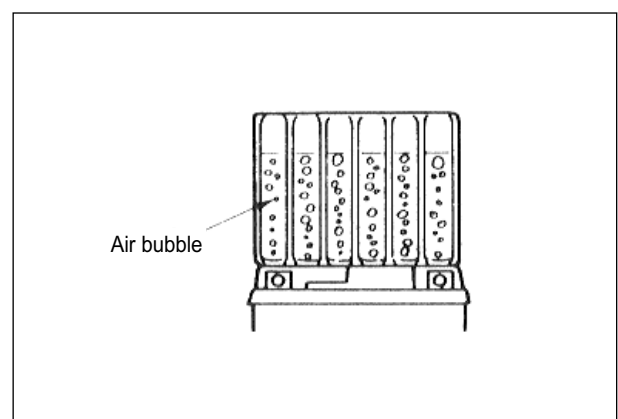

5-9 ELECTRICAL SYSTEM

⑤ Separation of electrolyte container

After confirming that you entered the electrolyte into battery completely, remove the electrolyte containers from the battery.

⚠ CAUTION

Draw the empty receptacle out slowly because there may be a chance which remaining electrolyte vaporize.

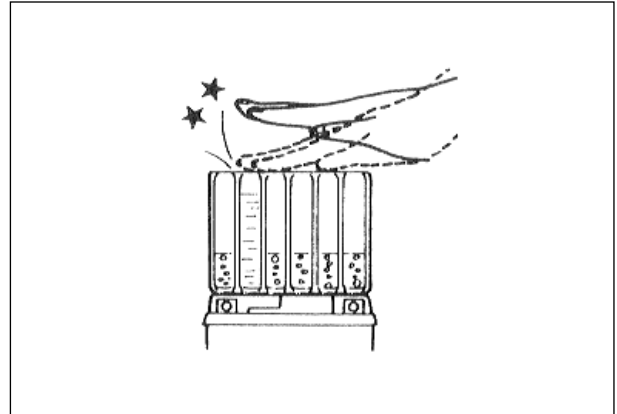

⑥ Insert of the caps

Insert the cap into the filler holes, pressing it firmly so that the top of the caps do not protrude above the upper surface of the battery's top cover.

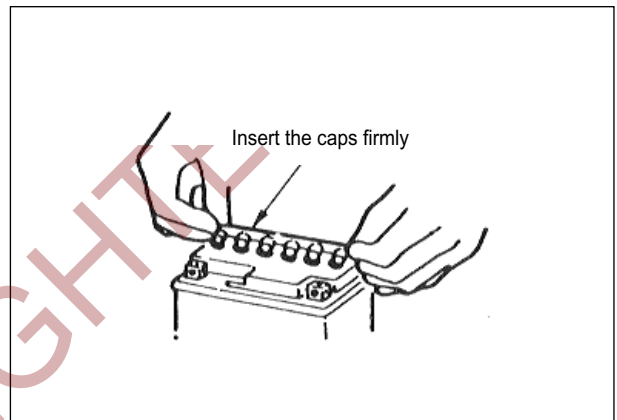

⊙ ASSISTANCE RECHARGING

Use the battery that is made after 2 years as the maintenance free battery.

Use the battery at condition of the high temperature.

Assistance recharging to the following points.

- The main principle of assistance recharging.
Assistance recharging from rule of electric current or voltage, when the battery discharged.
- Do not assistance recharge except the right side table.
- In times of recharging the battery, please do it at the condition of removal of the lead wire.

⚠ WARNING

The firearm is strictly prohibited.

Assistance Recharging

Standard	0.5A × 5 hours
Fast	5A × 30 minutes.

CHASSIS

CONTENTS

FRONT WHEEL AND BRAKE	6- 1
REMOVAL	6- 2
INSPECTION AND DISASSEMBLY	6- 3
REASSEMBLY AND REMOUNTING	6- 4
STEERING AND FRONT SUSPENSION	6- 6
REMOVAL AND DISASSEMBLY	6- 6
INSPECTION	6- 9
REASSEMBLY AND REMOUNTING	6-10
TOE-IN ADJUSTMENT	6-11
REAR WHEEL	6-12
REMOVAL	6-12
INSPECTION	6-12
REMOUNTING	6-12
REAR BRAKE	6-13
BRAKE PAD REPLACEMENT	6-13
CALIPER DISASSEMBLY	6-13
DISC PLATE INSPECTION	6-14
CALIPER REASSEMBLY	6-14
REAR AXLE HOUSING, AXLE SHAFT AND SHOCK ABSORBER	6-15
REMOVAL	6-15
INSPECTION AND DISASSEMBLY	6-16
REASSEMBLY AND REMOUNTING	6-18

FRONT WHEEL AND BRAKE

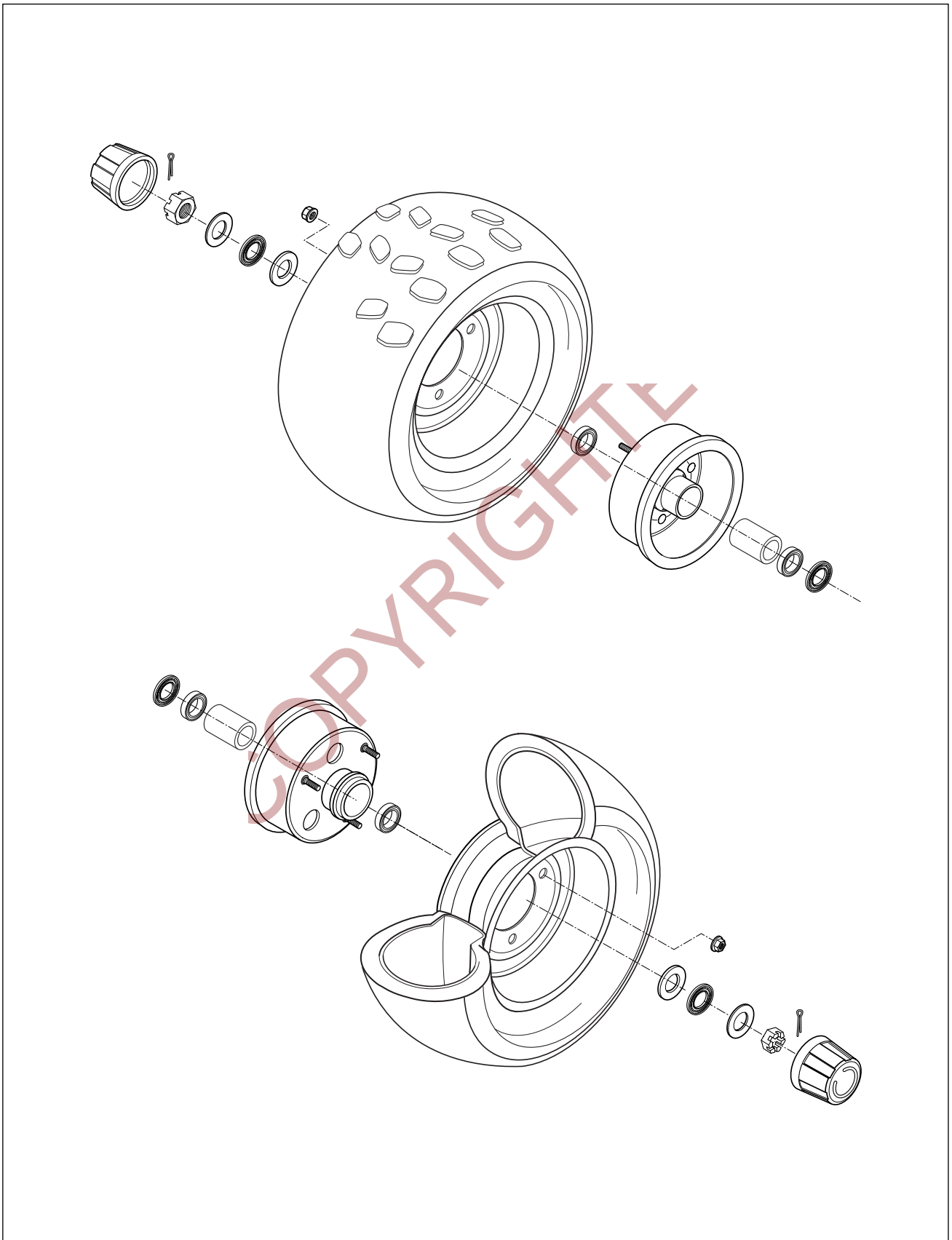

REMOVAL

- Place the vehicle on level ground.
- Remove the wheel center cap.
- Remove the cotter pin and front axle nut.
- Support the vehicle by jack or block and remove the front wheel.



- Remove the brake shoe.



- Remove the brake cam lever.



- Remove the front brake plate.



6-3 CHASSIS

INSPECTION AND DISASSEMBLY

⊙ WHEEL HUB BEARING

Inspect the play of bearing inner ring by hand while mounted in the wheel hub.

Rotate the inner ring by hand to inspect if any abnormal noise occurs or it rotates smoothly.

Replace the bearing if there is anything unusual.

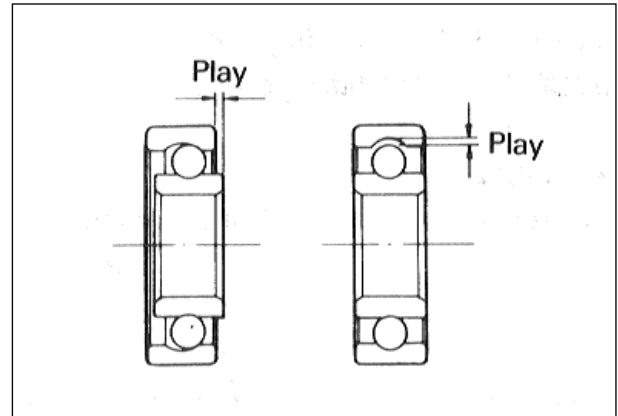

- Remove the spacer.
- Remove the inner and outer dust seals with the special tool.

 **Oil seal remover : 09913-50121**

CAUTION

The removed dust seal should be replaced with new ones.



- Drive out the both bearings with the special tool in the following procedures.

 **Wheel bearing remover : 09941-50111**

- Insert the adapter into the bearing.
- After inserting the wedge bar from the opposite side, lock the wedge bar in the slit of the adapter.
- Drive out the bearing by knocking the wedge bar.

CAUTION

The removed bearing should be replaced with new one.

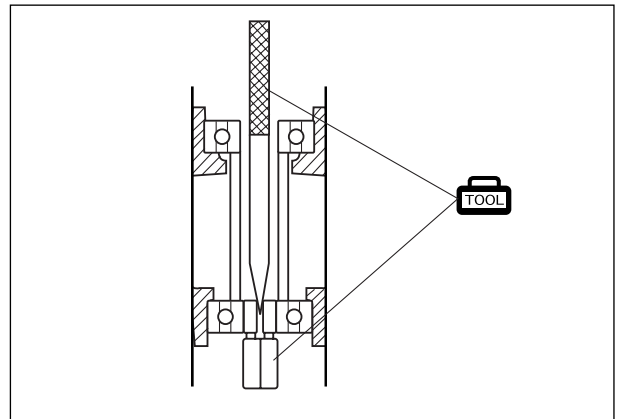

- ⊙ TIRE : Refer to page 2-11

⊙ BRAKE DRUM

Measure the brake drum I.D. to determine the extent of wear and, if the limit is exceeded by the wear noted, replace the brake drum.

The value of this limit is indicated inside of drum.

Brake drum I.D.	Service limit
	110.7 mm (4.358 in)



⊙ BRAKE SHOE

Check the brake shoe and decide whether it should be replaced or not from the thickness of brake lining.

Brake shoe lining thickness	Service limit
	2 mm (0.079 in)

⚠ CAUTION

Replace the brake shoe as a set, otherwise braking performance will be adversely affected.

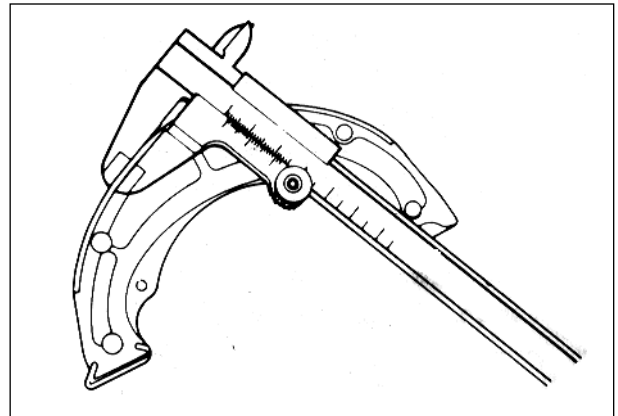

REASSEMBLY AND REMOUNTING

Reassemble and remount the front wheel and brake in the reverse order of removal and disassembly, and also carry out the following steps :

- When installing the brake camshaft, apply **SUPER GREASE "A"** to the camshaft and cam face.

 **SUPER GREASE "A"**

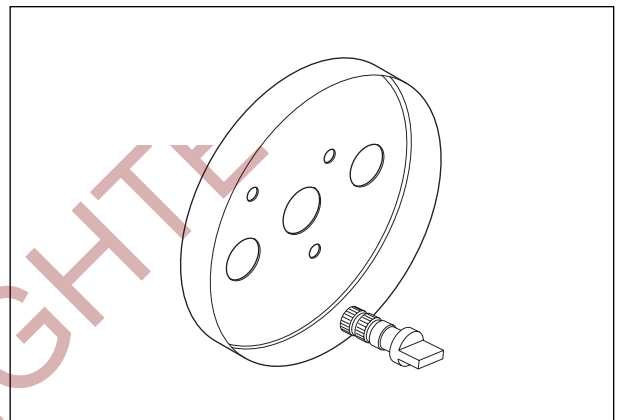

- Install the brake shoes with spring hooks faced inside.

⚠ CAUTION

Be careful not to apply too much grease to the cam and pin. If grease gets on the lining, brake slippage will result.



- Install the brake cam lever to the brake camshaft.
- Tighten the brake cam lever nut to the specified torque.

 **Front brake cam lever nut**
: 6~8 N · m (0.6~0.8 kg · m)



6-5 CHASSIS

- Apply **BOND "1215"** to the front brake plate as shown photo.

 **BOND "1215"**

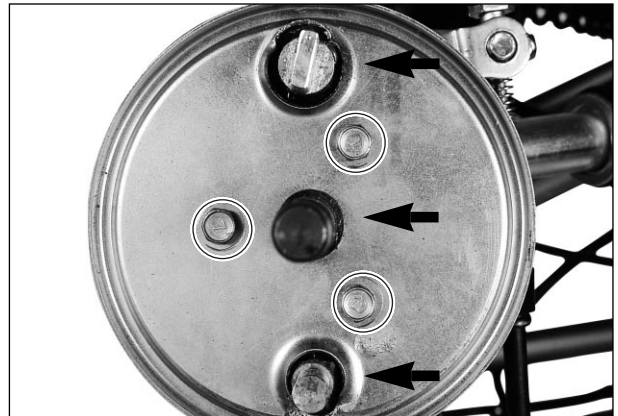

- Install the front brake drum and tire.

COPYRIGHT

STEERING AND FRONT SUSPENSION

TIGHTENING TORQUE		
ITEM	N · m	kg · m
①	18 ~ 28	1.8 ~ 2.8
②	18.4 ~ 28.6	1.84 ~ 2.86
③	22.4 ~ 35.7	2.24 ~ 3.57
④	40 ~ 50	4.0 ~ 5.0
⑤	80 ~ 100	8.0 ~ 10.0
⑥	22 ~ 35	2.2 ~ 3.5
⑦	22 ~ 35	2.2 ~ 3.5
⑧	40 ~ 60	4.0 ~ 6.0

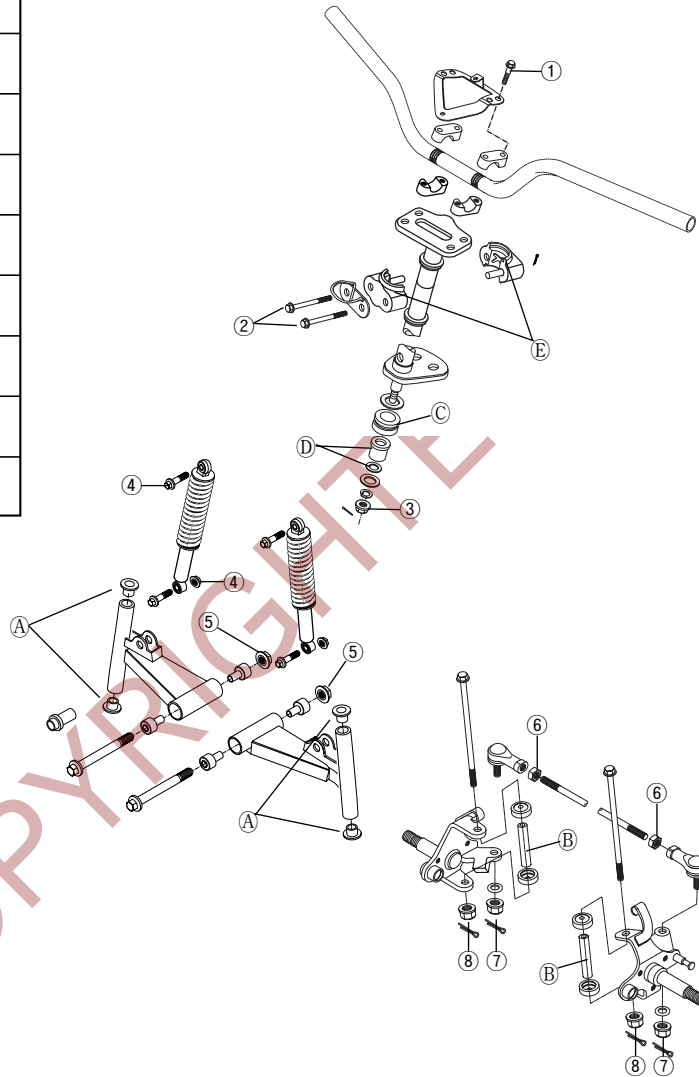

- (A) : ASSEMBLING APPLY GREASE
 (B) : ASSEMBLING APPLY GREASE
 (C) : APPLY GREASE TO LIPS
 (D) : APPLY GREASE
 (E) : ASSEMBLING APPLY GREASE

REMOVAL AND DISASSEMBLY

- Remove the front fender.
- Remove the front wheel and brake. (Refer to page 6-2)
- Remove the tie-rod end nut.
- Remove the steering knuckle.



6-7 CHASSIS

- Remove the suspension arm mounting bolts and front shock absorber upper mounting bolt.
- Remove the suspension arm with shock absorber.

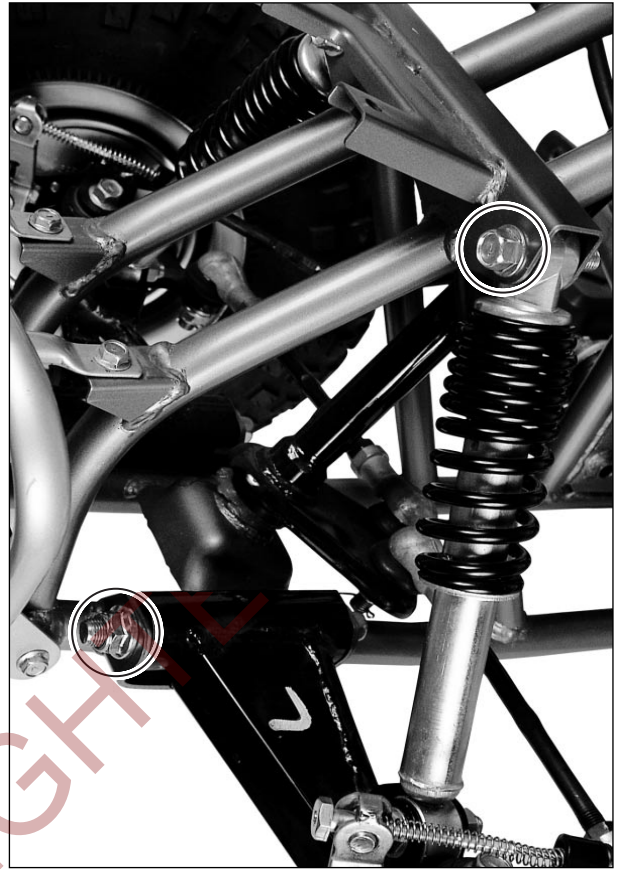

- Remove the shock absorber.



- Remove the dust seals and spacer.



- Remove the handlebar switch.
- Remove the throttle lever case.
- Remove the front brake lever holder.

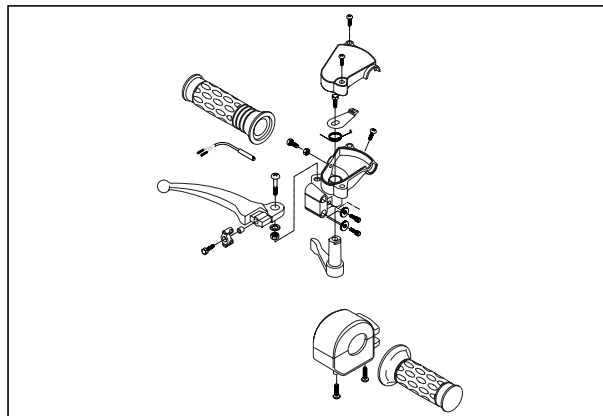

- Remove the front brake cables.



- Remove the steering head cover bracket and handlebar by removing the mounting bolts.

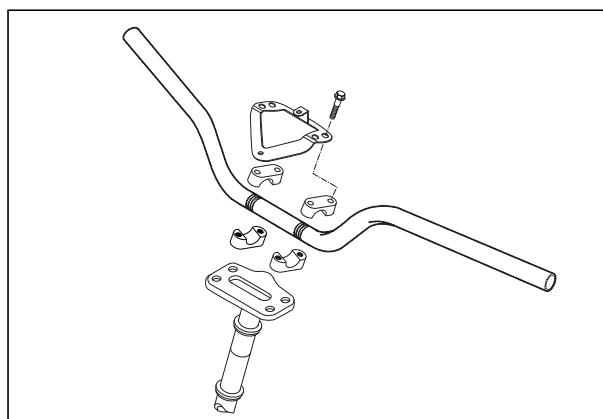

- Remove the tie-rods by removing the cotter pins and nuts.
- Remove the cotter pin and steering shaft lower nut.

⚠ CAUTION

The removed cotter pins should be replaced with new ones.



6-9 CHASSIS

- Separate the tie-rod ends ①, nuts ②, ③ and steering tie-rods ④.

⚠ CAUTION

Inside lock nuts ② are left-hand thread.

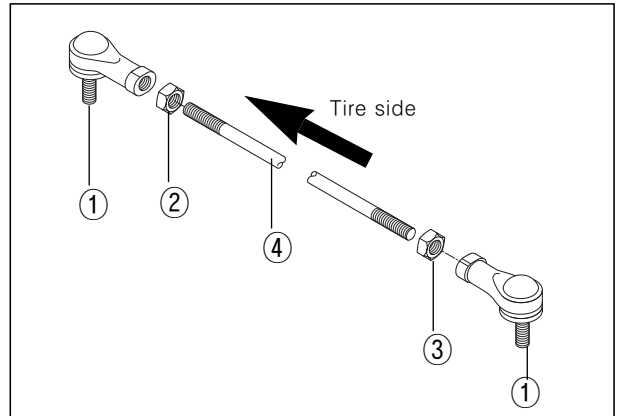

- Remove the cotter pins ⑤, and remove the steering shaft holder bolts ⑥.
- Remove the steering shaft holders and steering shaft.



INSPECTION

Inspect the removed parts for the following abnormalities.

- ❖ Handlebar distortion
- ❖ Handlebar clamp wear

⊙ DUST SEAL

Inspect the dust seals for damage.

⊙ TIE-ROD

Inspect the tie-rod for distortion and the boot for wear.

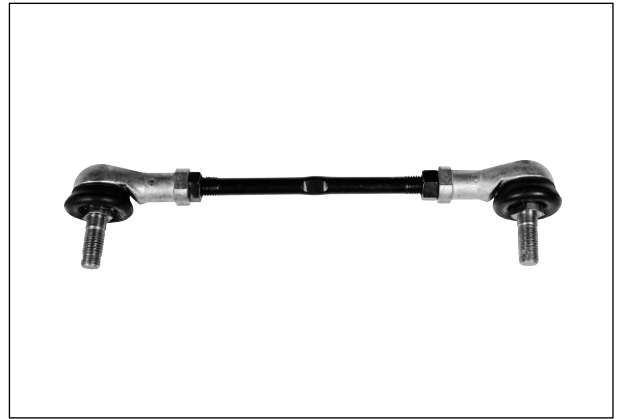

⊙ STEERING SHAFT AND HOLDER

Inspect the steering shaft for distortion or bend.

Inspect the two steering shaft holders for wear.

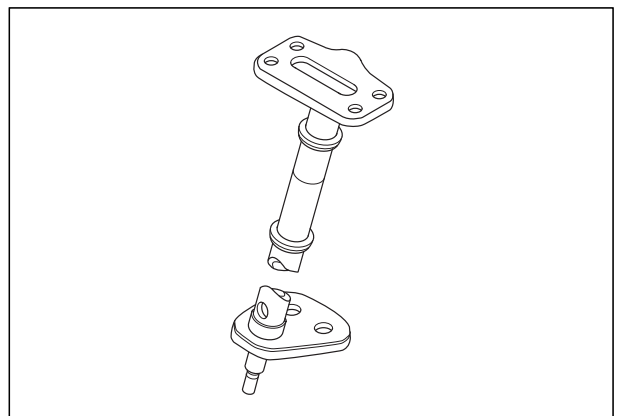
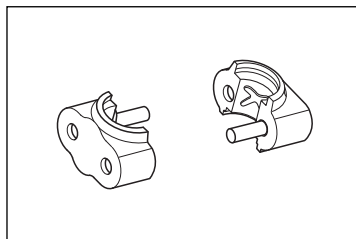

⊙ SHOCK ABSORBER

Inspect the shock absorber for oil leakage or other damage.

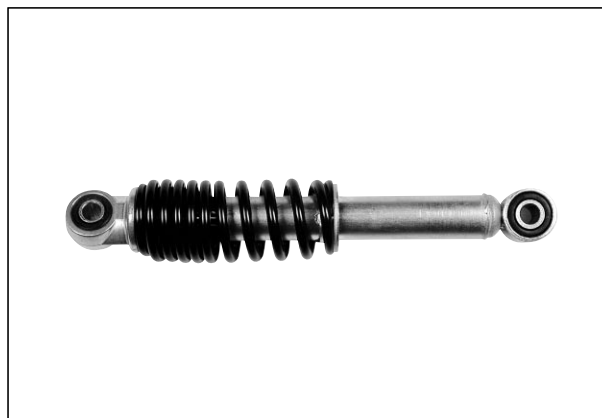

REASSEMBLY AND REMOUNTING

Reassemble and remount the steering system in the reverse order of removal and disassembly, and also carry out the following steps :

- Align the mating face of front brake holder with the respective punch mark and tighten the bolt.



⊙ TIE ROD

- Install the tie-rod ends ①, nuts ②, ③ and steering tie-rods ④.

⚠ CAUTION

Inside lock nuts ② are left-hand thread.

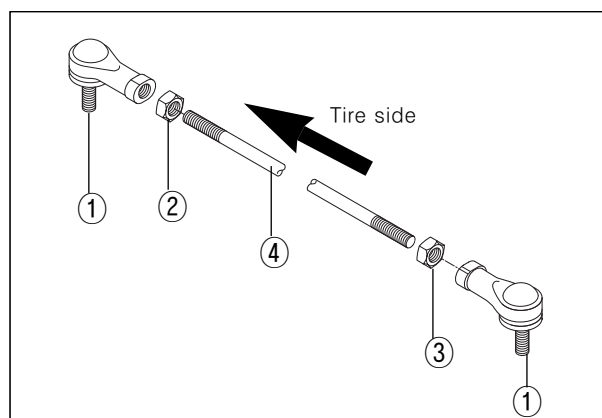

⊙ HANDLEBAR

- Install the handlebar with the punch mark aligned with the handlebar holder as shown.
- Tighten the handlebar holder bolts to the specified torque.



Handlebar holder bolt

: 18.4~28.6 N · m (1.84~2.86 kg · m)

NOTE :

The gap ⑤ between the handlebar holder should be even.

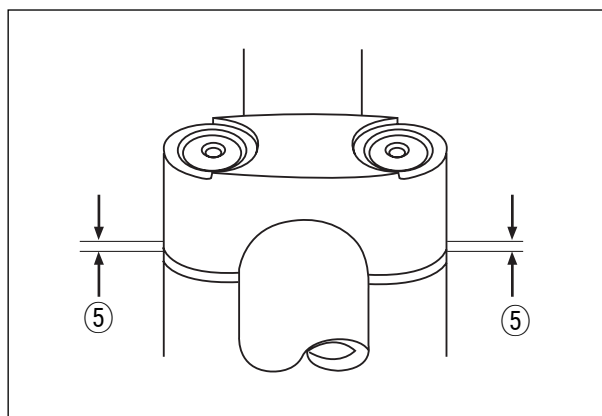

TOE-IN ADJUSTMENT

The procedure for adjusting the toe-in as follows.

- Place the vehicle on level ground and set the handle-bar straight.
Make sure that all tires are inflated to the standard pressure.

COLD INFLATION TIRE PRESSURE			
	kPa	kgf/cm ²	psi
Front	25	0.25	3.6
Rear	25	0.25	3.6

- Loosen the lock nuts ① on each tie-rod.

CAUTION

Inside lock nuts ① are left-hand thread.

- Measure the distances A and B of front wheels (in illustration) and adjust the tie-rods, right and left, to within the specified range.

Toe - in	8 mm (0.315 in)
----------	-----------------

NOTE :

A - B = Toe-in

- Temporarily tighten the four lock nuts.
- Check that the distances C and D (in the illustration) are equal. If the distances C and D are not equal, readjust the tie-rod, right or left, whichever makes the toe-in value closer to the specification. Check the toe-in again by measuring the distances A and B.
- If the toe-in is not within specification, repeat the adjustment as above until proper toe-in value is obtained and at the same time the distances C and D become equal.
- Tighten the four nuts ① after adjustment of toe-in is made.



Tie-rod lock nut

: 22.4~35.7 N · m (2.24~3.57 kg · m)

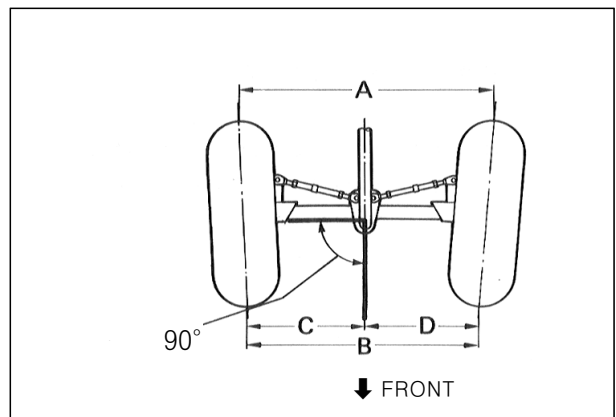
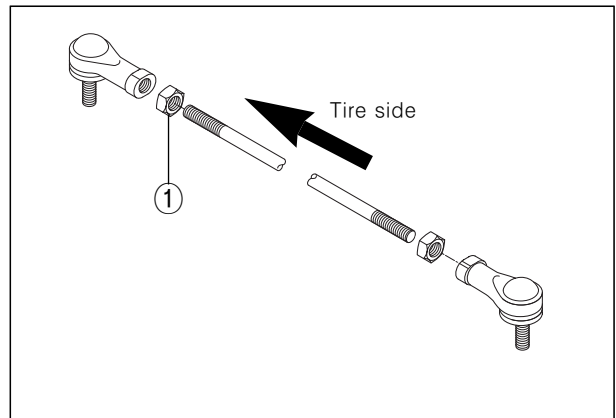

REAR WHEEL

TIGHTENING TORQUE		
ITEM	N · m	kg · m
①	60 ~ 90	6.0 ~ 9.0
②	20 ~ 30	2.0 ~ 3.0
③	22 ~ 35	2.2 ~ 3.5
④	22 ~ 35	2.2 ~ 3.5
⑤	120 ~ 150	12.0 ~ 15.0

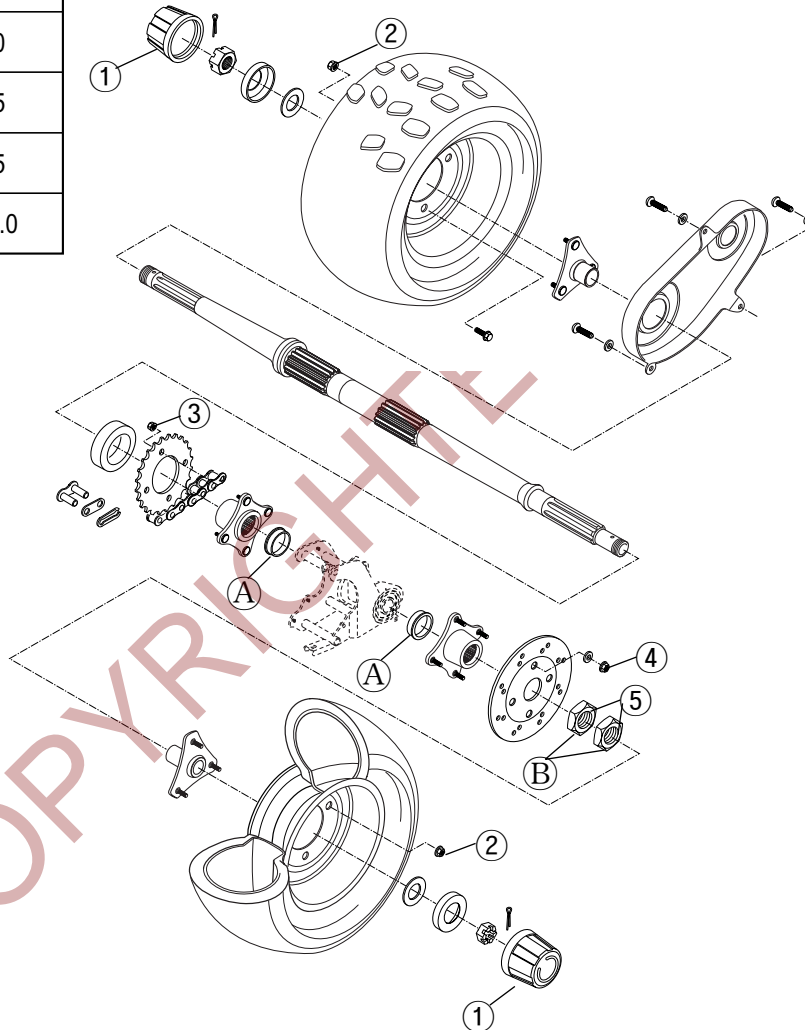

- Ⓐ : ASSEMBLING APPLY GREASE
 Ⓑ : ASSEMBLING APPLY LOCK TIGHT

REMOVAL

- Place the vehicle on level ground.
- Support the vehicle by jack or block.
- Remove the wheel center cap.
- Remove the cotter pin and rear hub nut.

INSPECTION

- ⊙ TIRE : Refer to page 2-11

REMOUNTING

Remount the rear wheel in the reverse order of removal.



REAR BRAKE

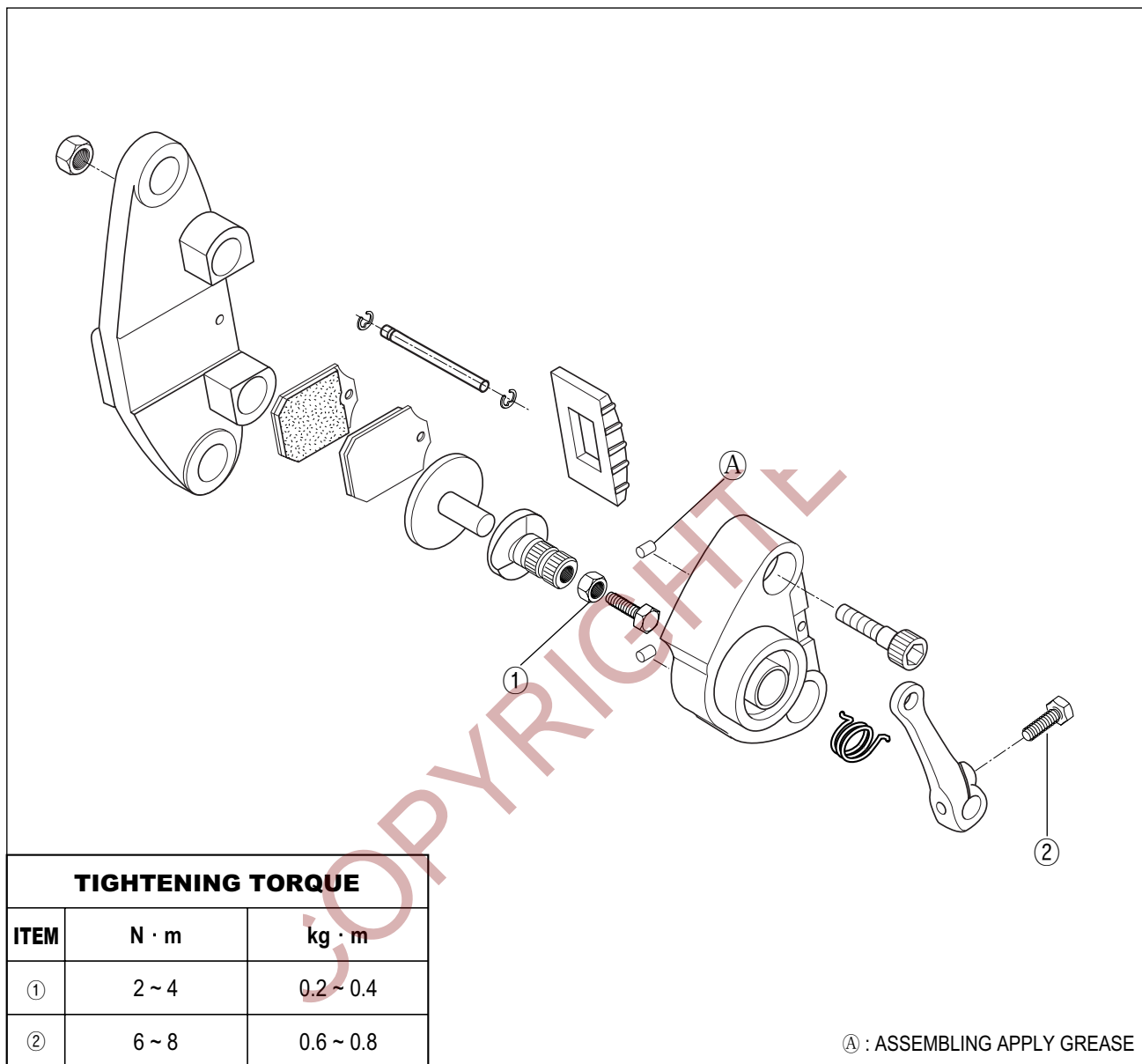

BRAKE PAD REPLACEMENT

- For replacing procedure of brake pad : Refer to page 2-9

CALIPER DISASSEMBLY

- Remove the brake lever bolt ① and caliper mounting bolts ②.
- Remove the caliper.
- Remove the brake pad. (Refer to page 2-9)

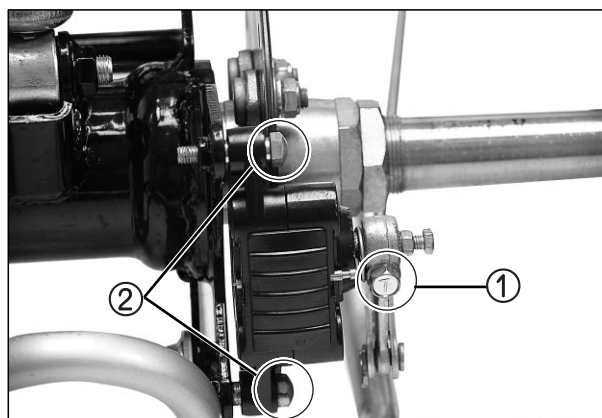

- Remove the rear caliper lever return spring .

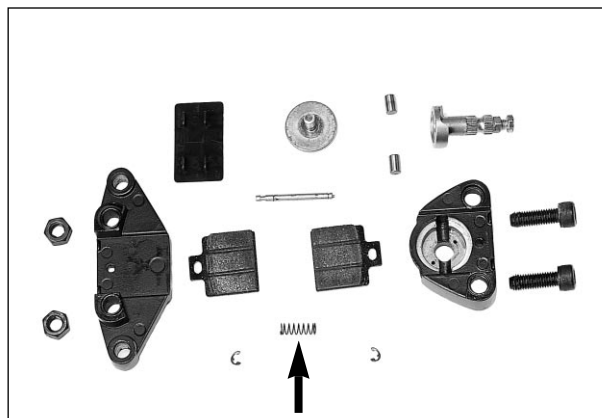

DISC PLATE INSPECTION

- Check the disc for wear with a micrometer. Replace the disc if the thickness exceeds the service limit.

Disc thickness	Service limit
	2.5 mm (0.098 in)

 **Micrometer(0~25mm) : 09900-20201**

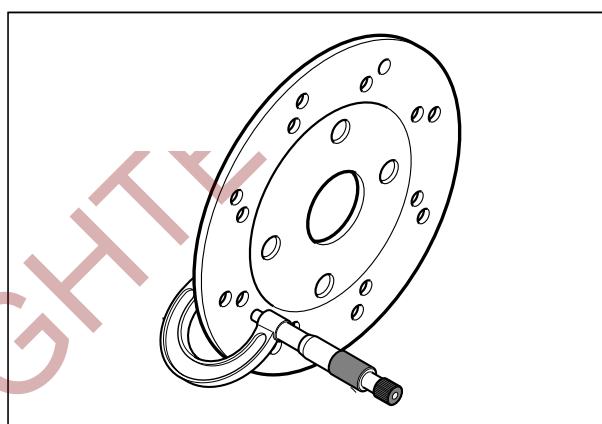

- Check the disc for face runout with a dial gauge as shown. Replace the disc if the runout exceeds the service limit

Disc runout	Service limit
	0.3 mm (0.012 in)

 **Dial gauge : 09900-20606**
Magnetic stand : 09900-20701

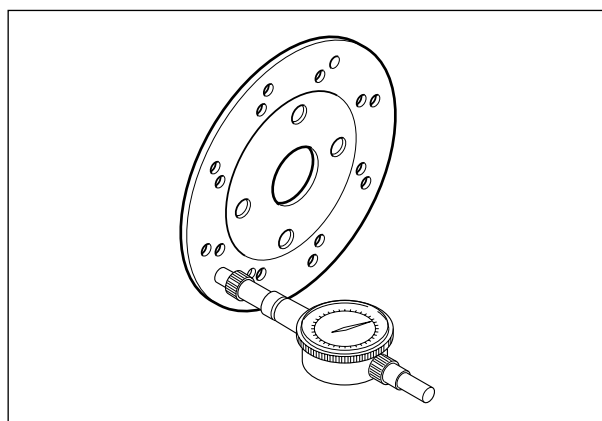

CALIPER REASSEMBLY

Reassemble and remount the caliper in the reverse order of removal and disassembly, and also carry out the following steps.

- Tighten the brake lever bolt ① and caliper mounting bolts ② to the specified torque.

SPECIFIED TORQUE		
Item	N · m	kg · m
Rear brake caliper lever bolt ①	6 ~ 8	0.6 ~ 0.8
Rear brake caliper mounting bolt ②	5 ~ 7	0.5 ~ 0.7

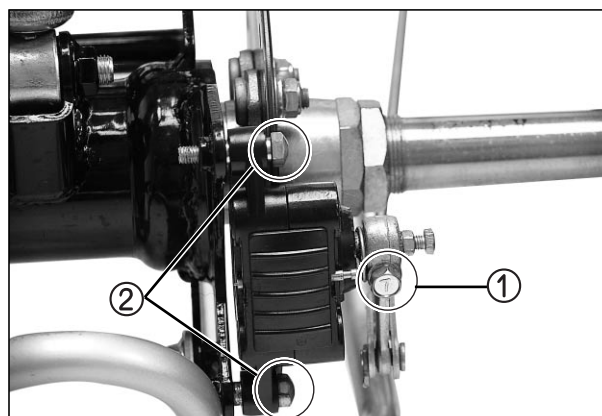

REAR AXLE HOUSING, AXLE SHAFT AND SHOCK ABSORBER

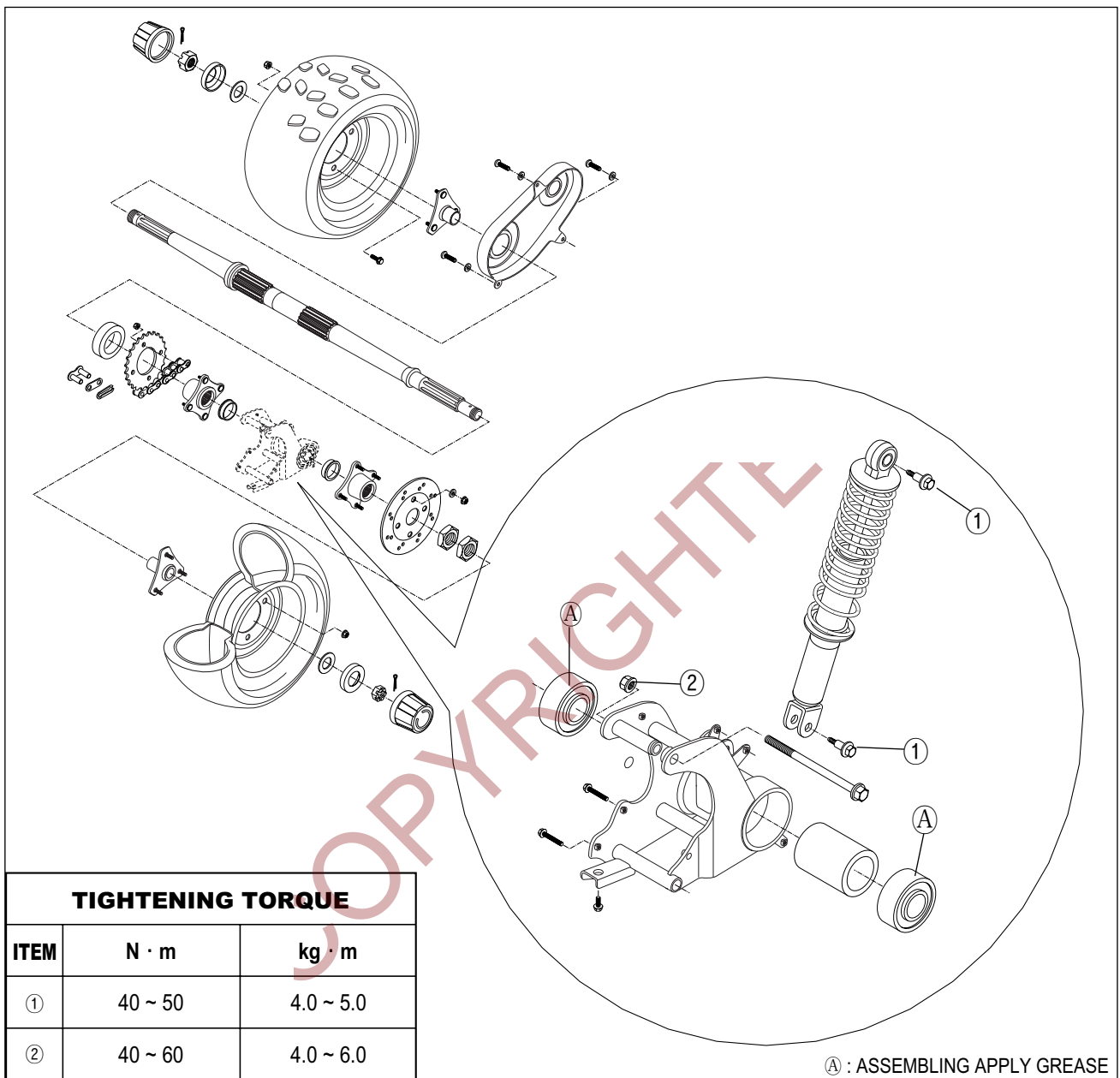

REMOVAL

- Remove the rear wheel. (Refer to page 6-12)
- Remove the rear brake. (Refer to page 6-13)
- Remove the chain cover.
- Remove the axle shaft with rear sprocket.

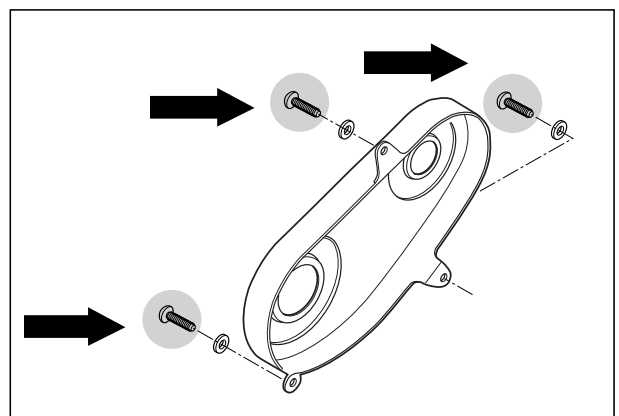

- Remove the shock absorber.

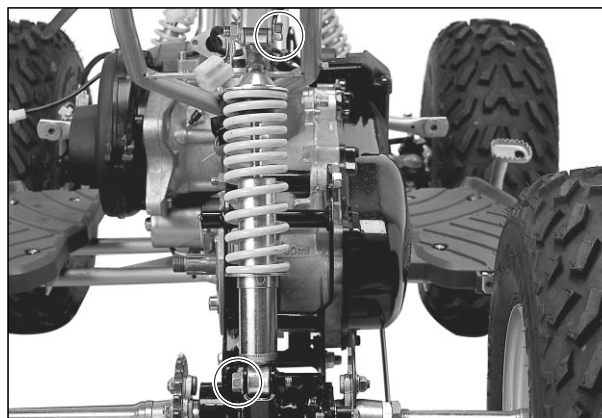

- Remove the rear axle housing.

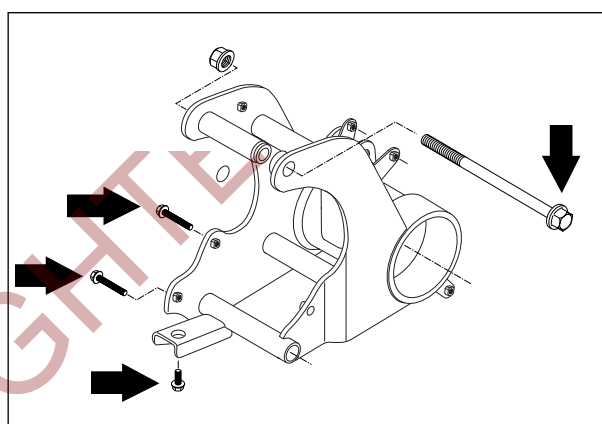

- Remove the sprocket mounting flange by removing the nut.

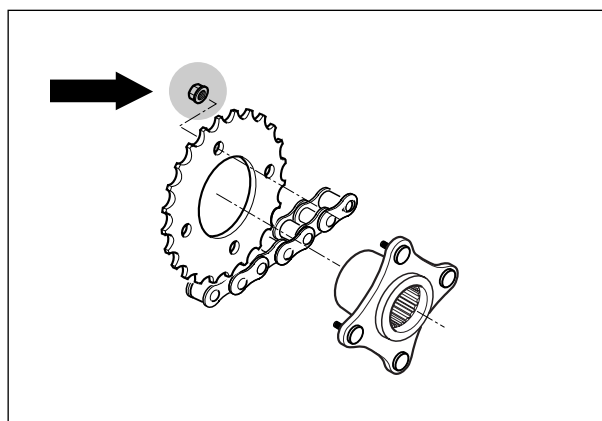

INSPECTION AND DISASSEMBLY

⊙ **AXLE HOUSING BEARING**

Inspect the play of bearing inner ring by hand while mounting in the axle housing.

Rotate the inner ring by hand to inspect if any abnormal noise occurs or it rotates smoothly.

Replace the bearing if there is anything unusual.

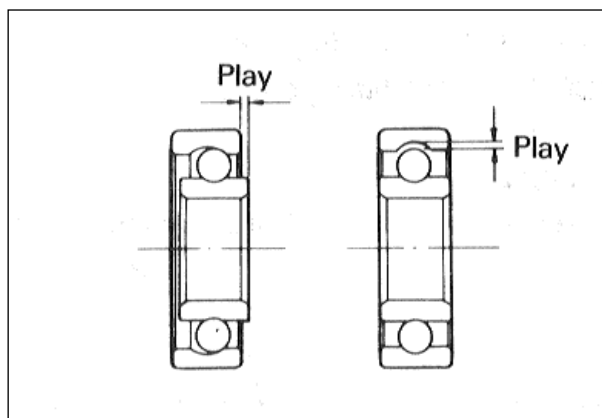

6-17 CHASSIS

- Remove the dust seals with the special tool.

 Oil seal remover : 09913-50121

 **CAUTION**

Replace the removed dust seals with new ones.

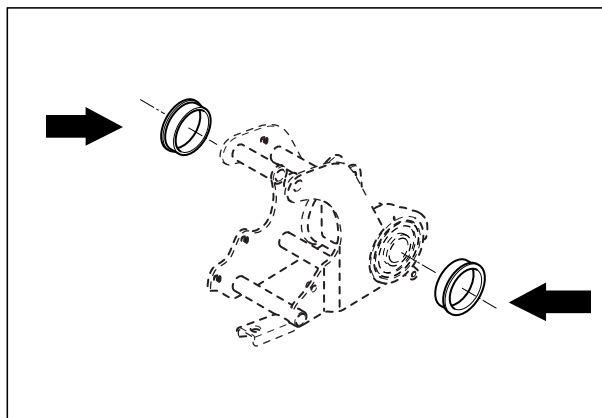

- Remove the right and left bearings and spacer.

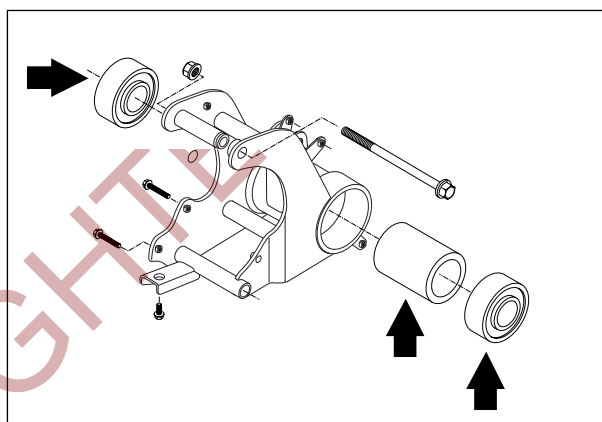

⊙ SHOCK ABSORBER

Inspect the rear shock absorber for oil leakage or other damage.



⊙ REAR SPROCKET

Inspect the sprocket's teeth for wear. If they are worn as illustrated, replace the sprocket and drive chain as a set.

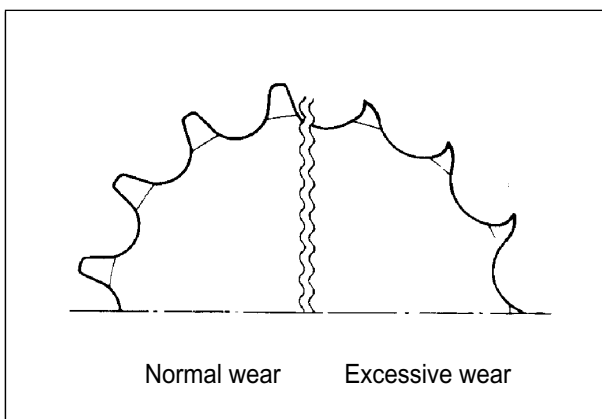

- Remove the rear sprocket.



⊙ REAR AXLE SHAFT

Using a dial gauge, check the axle shaft for runout and replace it if the runout exceeds the limit.

Rear axle shaft runout	Service limit
	0.5 mm (0.02 in)

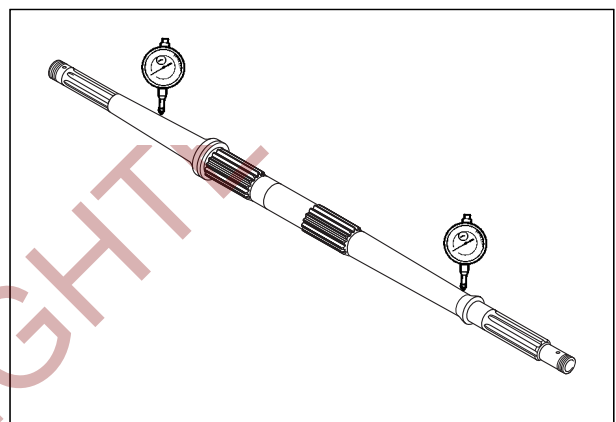

REASSEMBLY AND REMOUNTING

Reassemble and remount the rear axle housing in the reverse order of removal and disassembly.

COPYRIGHT

SERVICING INFORMATION

CONTENTS

<i>TROUBLESHOOTING</i>	7- 1
<i>SPECIAL TOOLS</i>	7- 5
<i>TIGHTENING TORQUE</i>	7- 8
<i>SERVICE DATA</i>	7-10
<i>WIRE AND CABLE ROUTING</i>	7-16
<i>WIRING DIAGRAM</i>	7-20

TROUBLESHOOTING

ENGINE

Complaint	Symptom and possible causes	Remedy
Engine does not start, or is hard to start.	<p>Compression too low</p> <ol style="list-style-type: none"> Excessively worn cylinder or piston rings. Stiff piston ring in place. Gas leaks from the joint in crankcase, cylinder or cylinder head. Damaged reed valve. Spark plug too loose. Broken, cracked or otherwise failed piston. <p>Plug not sparking</p> <ol style="list-style-type: none"> Damaged spark plug or spark plug cap. Dirty or wet spark plug. Defective CDI & Ignition coil unit or stator coil. Open or short in high-tension cord. Defective ignition switch. <p>No fuel reaching the carburetor</p> <ol style="list-style-type: none"> Clogged hole in the fuel tank cap. Clogged or defective fuel cock. Defective carburetor float valve. Clogged fuel hose. 	<p>Replace. Repair or replace. Repair or replace. Replace. Tighten. Replace.</p> <p>Replace. Clean and dry. Replace. Replace. Replace.</p> <p>Clean. Clean or replace. Replace. Clean or replace.</p>
Engine stalls easily.	<ol style="list-style-type: none"> Carbon deposited on the spark plug. Defective CDI & Ignition coil unit. Clogged fuel hose. Clogged jets in carburetor. Clogged exhaust pipe. 	<p>Clean. Replace. Clean. Clean. Clean.</p>
Noisy engine.	<p>Noise appears to come from piston</p> <ol style="list-style-type: none"> Piston or cylinder worn down. Combustion chamber fouled with carbon. Piston pin, bearing or piston pin bore worn. Piston rings or ring grooves worn. <p>Noise seems to come from crankshaft</p> <ol style="list-style-type: none"> Worn or brunt crankshaft bearings. Worn or brunt conrod big-end bearings. <p>Noise seems to come from final gear box</p> <ol style="list-style-type: none"> Gears worn or rubbing. Badly worn splines. Worn or damaged bearings of drive shaft for rear axle shaft. 	<p>Replace. Clean. Replace. Replace.</p> <p>Replace. Replace.</p> <p>Replace. Replace. Replace.</p>
Slipping clutch	<ol style="list-style-type: none"> Worn or damaged clutch shoes. Worn clutch drum. 	<p>Replace. Replace.</p>
Engine idles poorly.	<ol style="list-style-type: none"> Excessively worn cylinder or piston rings. Stiff piston ring in place. Gas leaks from crankshaft oil seal. Spark plug gaps too wide. Defective CDI & Ignition coil unit. Defective magneto stator coil. Float-chamber fuel level out of adjustment in carburetor. Clogged jets in carburetor. Broken or damaged reed valve. 	<p>Replace. Replace. Replace. Adjust or replace. Replace. Replace. Replace. Clean or adjust. Replace.</p>

Complaint	Symptom and possible causes	Remedy
Engine runs poorly in high-speed range.	<ol style="list-style-type: none"> 1. Excessively worn cylinder or piston rings. 2. Stiff piston ring in place. 3. Spark plug gaps too narrow. 4. Ignition not advanced sufficiently due to poorly working CDI & Ignition coil unit. 5. Defective magneto stator coil. 6. Float-chamber fuel level too low. 7. Clogged air cleaner element. 8. Clogged fuel hose, resulting in inadequate fuel supply to carburetor. 9. Clogged fuel cock vacuum pipe. 	Replace. Replace. Adjust. Replace. Replace. Adjust or replace. Clean Clean, and replace. Clean.
Dirty or heavy exhaust smoke.	<ol style="list-style-type: none"> 1. Too much engine oil to the engine. 2. Use of incorrect engine oil. 	Check oil pump. Change.
Engine lacks power.	<ol style="list-style-type: none"> 1. Excessively worn cylinder or piston rings. 2. Stiff piston ring in place. 3. Gas leaks from crankshaft oil seal. 4. Spark plug gaps incorrect. 5. Clogged jets in carburetor. 6. Float-chamber fuel level out of adjustment. 7. Clogged air cleaner element. 8. Fouled spark plug. 9. Sucking air from intake pipe. 10. Slipping or worn V-belt. 11. Damaged/worn rollers in the movable drive face. 12. Weakened movable driven face spring. 13. Too rich fuel/air mixture due to defective starter system. 	Replace. Replace. Replace. Adjust or replace. Clean. Adjust or replace. Clean. Clean or replace. Retighten or replace. Replace. Replace. Replace. Replace.
Engine overheats.	<ol style="list-style-type: none"> 1. Heavy carbon deposit on piston crown. 2. Defective oil pump or clogged oil circuit. 3. Fuel level too low in float chamber. 4. Air leakage from intake pipe. 5. Use of incorrect engine oil. 6. Use of improper spark plug. 7. Clogged exhaust pipe/muffler. 	Clean. Replace or clean. Adjust or replace. Retighten or replace. Change. Change. Clean or replace.

CARBURETOR

Complaint	Symptom and possible causes	Remedy
Trouble with starting.	<ol style="list-style-type: none"> 1. Starter jet is clogged. 2. Air leaking from a joint between starter body and carburetor. 3. Air leaking from carburetor's joint or vacuum hose joint. 4. Starter plunger is not operating properly. 	Clean. Check starter body and carburetor for tightness, and replace gasket. Check and replace. Check and replace.
Idling or low-speed trouble.	<ol style="list-style-type: none"> 1. Pilot jet, pilot air jet are clogged or loose. 2. Air leaking from carburetor's joint, vacuum pipe joint, or starter. 3. Pilot outlet is clogged. 4. Starter plunger is not fully closed. 	Check and clean. Clean and replace. Check and clean. Check and replace.
Medium or high-speed trouble.	<ol style="list-style-type: none"> 1. Main jet or main air jet is clogged. 2. Needle jet is clogged. 3. Fuel level is improperly set. 4. Throttle valve is not operating properly. 5. Fuel filter is clogged. 	Check and clean. Check and clean. Check and replace. Check throttle valve for operation. Check and clean.
Overflow and fuel level fluctuations.	<ol style="list-style-type: none"> 1. Needle valve is worn or damaged. 2. Spring in deedle valve is broken. 3. Float is not working properly. 4. Foreign matter has adhered to needle valve. 5. Fuel level is too high or low. 	Replace. Replace. Check and adjust. Clean. Adjust or replace.

7-3 SERVICING INFORMATION

ELECTRICAL

Complaint	Symptom and possible causes	Remedy
No sparking or poor sparking.	<ol style="list-style-type: none"> 1. Defective CDI & Ignition coil unit. 2. Defective spark plug. 3. Defective magneto stator coil. 4. Loose connection of lead wire. 	Replace. Replace. Replace. Connect/tighten.
Spark plug soon becomes fouled with carbon.	<ol style="list-style-type: none"> 1. Mixture too rich. 2. Idling speed set too high. 3. Incorrect gasoline. 4. Dirty element in air cleaner. 5. Spark plug too cold. 6. Incorrect engine oil. 	Adjust carburetor. Adjust carburetor. Change. Clean. Replace by hot type plug. Replace.
Spark plug electrodes overheat or burn.	<ol style="list-style-type: none"> 1. Spark plug too hot. 2. The engine overheats. 3. Spark plug loose. 4. Mixture too lean. 5. Not enough engine oil. 	Replace by hot type plug. Turn up. Retighten. Adjust carburetor. Check oil pump.
Magneto does not charge.	<ol style="list-style-type: none"> 1. Open or short in lead wires, or loose lead connections. 2. Shorted, grounded or open magneto coil. 3. Shorted or open regulator/rectifier. 	Repair, replace or retighten. Replace. Replace.
Magneto charge, but charging rate is below the specifications.	<ol style="list-style-type: none"> 1. Lead wires tend to get shorted or open-circuited or loosely connected at terminal. 2. Grounded or open-circuited stator coils of magneto. 3. Defective regulator/rectifier. 4. Defective cell plates in the battery. 	Repair, or retighten. Replace. Replace. Replace the battery.
Magneto overcharges	<ol style="list-style-type: none"> 1. Internal short-circuit in the battery. 2. Resistor element in the regulator/rectifier damaged or defective. 3. Regulator/rectifier unit poorly grounded. 	Replace the battery. Replace. Clean and tighten ground connection.
Unstable charging.	<ol style="list-style-type: none"> 1. Lead wire insulation frayed due to vibration, resulting in intermittent shorting. 2. Magneto coil internally shorted. 3. Defective regulator/rectifier. 	Repair or replace. Replace. Replace.
Starter switch is not effective.	<ol style="list-style-type: none"> 1. Battery run down. 2. Defective switch contacts. 3. Brushes not seating properly on commutator in starter motor. 4. Defective starter relay. 5. Defective starter pinion gears. 6. Defective front or rear brake light switch circuit. 	Recharge or replace. Replace. Repair or replace. Replace. Replace. Replace or repair.







BATTERY



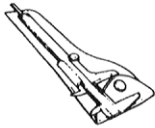

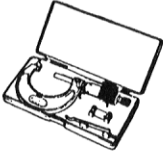

Complaint	Symptom and possible causes	Remedy
Battery runs down quickly.	<ol style="list-style-type: none"> 1. The charging method is not correct. 2. Cell plates have lost much of their active material as a result of over-charging. 3. A short-circuit condition exists within the battery due to excessive accumulation of sediments caused by the incorrect electrolyte. 4. Battery is too old. 	Check the magneto and regulator/rectifier circuit connections, and make necessary adjustments to obtain specified charging operation. Replace the battery, and correct the charging system. Replace the battery. Replace the battery.
Reversed battery polarity.	<ol style="list-style-type: none"> 1. The battery has been connected the wrong way round in the system, so that it is being charged in the reverse direction. 	Replace the battery and be sure to connect the battery properly.
Battery discharges too rapidly.	<ol style="list-style-type: none"> 1. Dirty container top and sides. 2. Battery is too old. 	Clean. Replace.

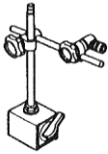
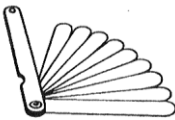

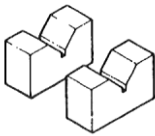
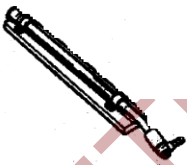

CHASSIS



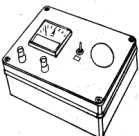

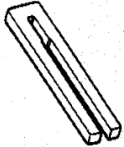
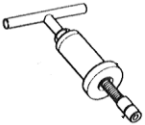
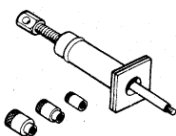
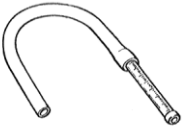

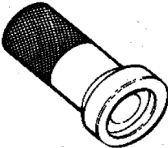

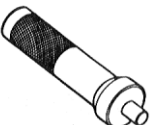
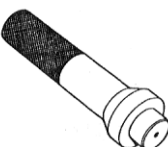
Complaint	Symptom and possible causes	Remedy
Handling feels too heavy or stiff.	<ol style="list-style-type: none"> 1. Disturbed front wheel alignment. 2. Poorly lubricated. 3. Not enough pressure in tires. 4. Tie-rod ends tending to seize. 5. Linkage connections tending to seize. 	Adjust. Lubricate. Adjust. Replace. Replace or replace.
Steering oscillation	<ol style="list-style-type: none"> 1. Wheel tires inflated unequally. 2. Wobbly wheels. 3. Loose nut on wheel hub. 4. Damaged or worn wheel hub bearing. 5. Worn or loose tie-rod ends. 6. Defective or incorrect tires. 7. Damaged wishbone arm bushing. 8. Loosen bolts and nuts on chassis. 	Adjust tire pressure. Replace. Retighten. Replace. Replace or retighten. Replace. Replace. Retighten.
Steering pulling to one side.	<ol style="list-style-type: none"> 1. Wheel tires unequally inflated. 2. Disturbed front wheel alignment. 3. Worn or broken wheel hub bearing. 4. Distorted frame. 5. Defective shock absorber. 	Adjust tire pressure. Adjust. Replace. Repair or replace. Replace.
Shocks coming to steering	<ol style="list-style-type: none"> 1. Tire inflating pressure too high. 2. Worn steering linkage connections. 3. Loose bolts on suspension system. 	Adjust. Replace. Retighten.
Rapid wear or uneven wear of tires.	<ol style="list-style-type: none"> 1. Worn or loosen wheel hub bearing. 2. Desturbed front wheel alignment. 	Replace. Adjust.
Steering noise.	<ol style="list-style-type: none"> 1. Loose bolt and nut. 2. Broken or otherwise damaged wheel hub bearing. 3. Poorly lubricated. 	Retighten. Replace. Lubricate.
Front suspension too soft.	<ol style="list-style-type: none"> 1. Weakened spring. 2. Oil leakage of shock absorber. 	Replace. Replace.
Front suspension too shift.	<ol style="list-style-type: none"> 1. Worn wishbone arm related bushing. 	Replace.
Noisy suspension.	<ol style="list-style-type: none"> 1. Loose bolt on suspension system. 2. Worn wishbone arm related bushing. 	Retighten. Replace.
Rear wheel oscillation.	<ol style="list-style-type: none"> 1. Worn or loose rear axle housing bearing. 2. Defective or incorrect tire. 3. Distorted wheel rim. 4. Loose nut on wheel hub. 5. Loose nut on axle shaft. 	Replace. Replace. Replace. Retighten. Retighten.
Rear suspension too soft.	<ol style="list-style-type: none"> 1. Weakened spring. 2. Rear shock absorber spring improperly set. 3. Oil leakage of rear shock absorber. 	Replace. Reset. Replace.
Rear suspension too stiff.	<ol style="list-style-type: none"> 1. Rear shock absorber spring improperly set. 2. Shock absorber shaft bent. 3. Swingarm bent. 4. Worn swingarm related bearing. 	Adjust. Replace. Replace. Replace.
Poor braking	<ol style="list-style-type: none"> 1. Lining worn down. 2. Too much play on brake lever and pedal. 	Replace. Adjust.

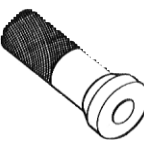
SPECIAL TOOLS

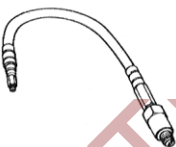
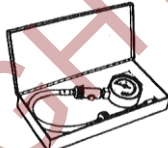
Special tools	Part Number · Part Name · Description
	09900-20101 Vernier Caliper Used to conveniently measure various dimensions.
	09900-20201 Micrometer(0~25mm) Used for precise measurement (00-25mm measure ranges).
	09900-20202 Micrometer(25~50mm) Used for precise measurement (25-50mm measure ranges).
	09900-20203 Micrometer(50~75mm) Used for precise measurement (50-75mm measure ranges).
	09900-20508 Cylinder gauge set Measure inside diameter of cylinder.
	09900-20605 Dial calipers Meassure width of conrod big-end.
	09900-20606 Dial gauge Measure oscillation of wheel with using magnetic stand.
	09900-20701 Magnetic stand With using dial gauge.
	09900-20806 Thickness gauge Measure clearance of piston ring.

Special tools	Part Number · Part Name · Description
	09900-21109 Torque wrench Measure torque of tightening.
	09900-21304 V-block With using magnetic stand.
	09900-21602 CCI oil gauge A gauge to inspect performance of oil pump.
	09900-22301 Plastigauge Measure clearance of crankshaft thrust.
	09900-22401 Small bore gauge Measure inside diameter of conrod small-end.
	09900-25002 Pocket tester Measure voltage, electric current, resistance.
	09900-26006 Engine tachometer Measure rotational frequency of engine.
	09900-28107 Electro tester Inspect ignition coil.
	09900-28500 Battery charger Used to charge the dischared battery.

Special tools	Part Number · Part Name · Description
	09910-20115 Conrod holder
	Used to lock the crankshaft.
	09910-32812 Crankshaft installer
	Used to install the crankshaft in the crankcase.
	09910-34510 Piston pin puller
	Use to remove the piston pin.
	09913-10760 Fuel level gauge
	Measure height of carburetor.
	09913-50121 Oil seal remover
	Used to remove the oil seal.
	09913-70122 Bearing installer
	Used to drive bearing in.
	09913-75520 Bearing installer
	Used to drive bearing in.
	09913-75820 Bearing installer
	Used to drive bearing in.
	09913-75830 Bearing installer
	Used to install rear axle shaft oil seal.

Special tools	Part Number · Part Name · Description
	09913-76010 Bearing installer
	Used to drive crankshaft bearing in.
	09913-80112 Bearing installer
	Used to drive bearing in.
	09915-63310 Compression gauge adapter
	Used with compression gauge.
	09915-64510 Compression gauge
	Measure cylinder compression.
	09920-13120 Crankcase separator
	Separate to crankcase.
	09921-20200 Bearing remover(10mm)
	Used to remove oil seal or bearing.
	09921-20210 Bearing remover(12mm)
	Used to remove oil seal or bearing.
	09923-73210 Bearing remover(17mm)
	Used to remove bearing with the rotor remove sliding shaft.
	09923-74510 Bearing remover(20~35mm)
	Used to remove bearing with the rotor remove sliding shaft.

7-7 SERVICING INFORMATION

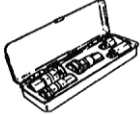
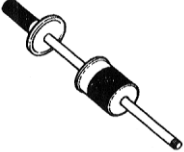
Special tools	Part Number · Part Name · Description
	09924-84521 Bearing installer
	Used to drive small bearing in.
	09930-10121 Spark plug socket wrench set
	Used to remove or remounting spark plug.
	09930-30102 Rotor remove sliding shaft
	Used to with bearing remover or rotor remover.

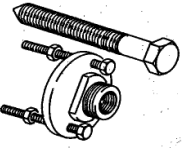
Special tools	Part Number · Part Name · Description
	09930-30163 Rotor remover
	Attached to the top of sliding shaft when removing rotor.
	09930-40113 Rotor holder
	Widely used to lock rotary parts such as a clutch shoe.
	09941-50111 Wheel bearing remover
	Used to remove wheel bearing.

COPYRIGHT

TIGHTENING TORQUE

ENGINE

ITEM	N · m	kg · m
Magneto rotor nut	35 ~ 45	3.5 ~ 4.5
Muffler mounting bolt	18 ~ 28	1.8 ~ 2.8
Exhaust pipe bolt	8 ~ 12	0.8 ~ 1.2
Spark plug	25 ~ 30	2.5 ~ 3.0
Cylinder head nut	18 ~ 28	1.8 ~ 2.8
Engine mounting link engine joint bolt	70 ~ 100	7.0 ~ 10.0
Engine mounting link frame joint bolt	70 ~ 100	7.0 ~ 10.0
Transmission oil drain plug	4 ~ 7	0.4 ~ 0.7
Transmission oil level bolt	4 ~ 7	0.4 ~ 0.7
Oil pump bolt	3 ~ 5	0.3 ~ 0.5
Clutch shoe nut	40 ~ 60	4.0 ~ 6.0
Clutch housing nut	40 ~ 60	4.0 ~ 6.0
Fixed drive face nut	40 ~ 60	4.0 ~ 6.0

7-9 SERVICING INFORMATION

CHASSIS

ITEM	N · m	kg · m
Front brake cam lever nut	6 ~ 8	0.6 ~ 0.8
Front shock absorber bolt & nut	40 ~ 50	4.0 ~ 5.0
Rear sprocket nut	22 ~ 35	2.2 ~ 3.5
Rear shock absorber bolt	40 ~ 50	4.0 ~ 5.0
Rear axle nut (M28)	120 ~ 150	12.0 ~ 15.0
Rear brake caliper lever bolt	6 ~ 8	0.6 ~ 0.8
Rear brake disc bolt	22 ~ 35	2.2 ~ 3.5
Rear brake caliper mounting bolt	5 ~ 7	0.5 ~ 0.7
Front axle nut (M14)	50 ~ 80	5.0 ~ 8.0
Handlebar holder bolt	18.4 ~ 28.6	1.84 ~ 2.86
Tie-rod lock nut	22.4 ~ 35.7	2.24 ~ 3.57
Steering shaft bolt (M8)	18 ~ 28	1.8 ~ 2.8
Steering shaft lower nut	22.4 ~ 35.7	2.24 ~ 3.57

TIGHTENING TORQUE CHART

For other bolts and nuts who's torque is not listed, refer to this chart :

Bolt Diameter (mm)	Conventional or "4" marked bolt		"7" marked bolt	
	N · m	kg · m	N · m	kg · m
4	1.0 ~ 2.0	0.1 ~ 0.2	1.5 ~ 3.0	0.15 ~ 0.3
5	2.0 ~ 4.0	0.2 ~ 0.4	3.0 ~ 6.0	0.3 ~ 0.6
6	4.0 ~ 7.0	0.4 ~ 0.7	8.0 ~ 12.0	0.8 ~ 1.2
8	10.0 ~ 16.0	1.0 ~ 1.6	18.0 ~ 28.0	1.8 ~ 2.8
10	22.0 ~ 35.0	2.2 ~ 3.5	40.0 ~ 60.0	4.0 ~ 6.0
12	35.0 ~ 55.0	3.5 ~ 5.5	70.0 ~ 100.0	7.0 ~ 10.0
14	50.0 ~ 80.0	5.0 ~ 8.0	110.0 ~ 160.0	11.0 ~ 16.0
16	80.0 ~ 130.0	8.0 ~ 13.0	170.0 ~ 250.0	17.0 ~ 25.0
18	130.0 ~ 190.0	13.0 ~ 19.0	200.0 ~ 280.0	20.0 ~ 28.0

SERVICE DATA**CYLINDER + PISTON + PISTON RING**

Unit : mm (in)

ITEM	STANDARD		LIMIT
Cylinder to piston clearance	0.073 ~0.083 (0.0029 ~ 0.0033)		0.120 (0.0047)
Cylinder bore	52.500 ~ 52.515 (2.0669 ~2.0675) Measure at 20mm from the top surface		52.590 (2.0705)
Piston diam.	52.432 ~ 52.447 (2.0643 ~2.0648) Measure at 20mm from the skirt end		52.332 (2.0603)
Cylinder distortion	—		0.05 (0.002)
Cylinder head distortion	—		0.05 (0.002)
Piston ring clearance (Free condition)	1st	Approx. 4.5 (0.177)	3.6 (0.142)
	2nd	Approx. 4.5 (0.177)	3.6 (0.142)
Piston ring clearance (Assembling condition)	1st	0.10 ~ 0.25 (0.004 ~ 0.010)	0.75 (0.030)
	2nd	0.10 ~ 0.25 (0.004 ~ 0.010)	0.75 (0.030)
Piston ring - ring groove clearance	1st	0.02 ~ 0.06 (0.0008 ~ 0.0024)	—
	2nd	0.02 ~ 0.06 (0.0008 ~ 0.0024)	—
Piston pin bore I.D	12.002 ~ 12.010 (0.4725 ~ 0.4728)		12.030 (0.4736)
Piston pin O.D	11.994 ~ 12.000 (0.4722 ~ 0.6302)		11.980 (0.4717)

CONROD + CRANKSHAFT

Unit : mm (in)

ITEM	STANDARD	LIMIT
Conrod small end bore I.D.	16.004 ~ 16.008 (0.6301 ~0.6302)	16.040 (0.6315)
Conrod big end runout	—	3.0 (0.12)
Crank web to wed width	40.0 ± 0.1 (1.575 ± 0.004)	—
Crankshaft runout	—	0.05 (0.002)

7-11 SERVICING INFORMATION

OIL PUMP

ITEM	STANDARD
Oil pump reduction ratio	30 : 1

CLUTCH

Unit : mm (in)

ITEM	STANDARD	LIMIT
Clutch housing I.D.	112.00 (4.4095)	112.50 (4.4291)
Clutch shoe thickness	4.5 (0.177)	2.0 (0.079)
Clutch in rpm	3,900 ± 200 rpm	————
Clutch tight rpm	5,900 ± 200 rpm	————

TRANSMISSION+DRIVE CHAIN

Unit : mm (in) Except ratio

ITEM	STANDARD	LIMIT
Final reduction ratio	1.33	————
Gear ratio	8.62	————
Transmission	2.842 ~ 1.042	————
Drive V-belt width	16.4 ~ 16.6 (0.6457 ~ 0.6535)	16.0 (0.6299)
Movable drive face spring free length	136.4 (5.370)	130.0 (5.118)
Drive chain	Type	428H
	Links	56
	20 - pitch length	254 (10.000)
Drive chain slack	5 ~ 15 (0.197 ~ 0.591)	Over 15 (Over 0.591)

CARBURETOR

Unit : mm (in)

ITEM	SPECIFICATION
Carburetor type	PB11M
Bore size	16.0 (0.630)
I.D. No.	HL41
Idle rpm	1,800 ± 100 rpm
Fuel level	8.0 (0.315)
Main jet (M.J.)	# 70
Main air jet (M.A.J.)	φ 2.1
Jet needle (J.N.)	2JM
Needle jet (N.J.)	φ 2.1
Pilot air jet (P.A.J.)	φ 2.1
Pilot jet (P.J.)	# 45
Throttle valve (T.V.)	3.5
By-pass (B.P.)	φ 1.0
Valve seat (V.S.)	1.0 (0.039)
Starter jet (G.S.)	# 45
Pilot screw (P.S.)	18°
Pilot outlet (P.O.)	0.8 (0.032)
Throttle cable play	0.5 ~ 1.0 (0.020 ~ 0.039)

7-13 SERVICING INFORMATION

ELECTRICAL

Unit : mm (in)

ITEM		SPECIFICATION	NOTE
Ignition timing		B.T.D.C. 8° at 1,000 rpm and B.T.D.C. 20° at 4,000 rpm	
Spark plug	Type	BPR7HS	
	Gap	0.6 ~ 0.7 (0.024 ~ 0.028)	
	Hot type	BPR6HS	
	Standard type	BPR7HS	
	Cold type	BPR8HS	
Spark performance		Over 8 (0.3) at 1 atm	
Ignition coil resistance	Primary	0.19 ~ 0.24 Ω	
	Secondary	5.4 ~ 6.6 kΩ	
Stator coil resistance	Lighting coil	0.54 ~ 0.80 Ω	Y/W-Ground
	Charging coil	0.69 ~ 1.03 Ω	W/R-Ground
	Exciting coil	146 ~ 220 Ω	B/R-Ground
	Pick-up coil	90 ~ 110 Ω	Br - W
Regulated voltage		13.0 ~ 16.0 V at 5,000 rpm	
No-load performance of A.C. generator		More than 17.0V (at 5,000 rpm)	
Starter motor carbon brush length		—————	3.5 (0.138)
Starter motor commutator under-cut		—————	0.2 (0.008)
Starter relay resistance		80 ~ 150 Ω	
Battery	Type designation	STX5L-BS (MF)	
	Capacity	12V 4Ah/10HR	
	Standard electrolyte S.G.	1.32 at 20°C (68°F)	
Fuse size		10A	

BRAKE + WHEEL

Unit : mm (in)

ITEM	STANDARD		LIMIT
Brake lever play	Front	5 ~15 (0.197 ~ 0.591)	————
Brake pedal play	Rear	15 ~25 (0.591 ~ 0.984)	————
Brake drum I.D.	Front	110.0 (4.330)	110.7 (4.358)
Brake shoe lining O.D.	Front	110.0 (4.330)	106.0 (4.173)
Brake shoe thickness	Front	4.0 (0.158)	2.0 (0.079)
Brake disc thickness	Rear	3.0 (0.118)	2.5 (0.098)
Brake disc runout	Rear	————	0.3 (0.012)
Turning radius		2,595 (102.165)	————
Camber		1°	————
Toe-in		8.0 (0.315)	————
Trail		15 (0.591)	————
Caster		5°	————
Wheel rim runout	Axial	————	1.2 (0.047)
	Radial	————	1.2 (0.047)
Wheel axle shaft runout	Rear	————	0.5 (0.020)
Tire size	Front	18 × 7.00 - 7	————
	Rear	18 × 7.00 - 7	————
Tire tread depth	Front	————	10 (0.394)
	Rear	————	10 (0.394)

7-15 SERVICING INFORMATION

SUSPENSION

Unit: mm (in)

ITEM	SPECIFICATION	LIMIT
Front wheel travel	75 (2.953)	—
Rear wheel travel	56.6 (2.228)	—

TIRE PRESSURE

COLD INFLATION TIRE PRESSURE	kPa	kgf/cm ²	psi
FRONT	25	0.25	3.6
REAR	25	0.25	3.6

FUEL + OIL

ITEM	SPECIFICATION		NOTE
Fuel type	Gasoline used should be graded 85 ~ 95 octane or higher. An unleaded gasoline is recommended.		
Fuel tank capacity	4.0 ℓ		
Engine oil type	Use HYOSUNG HYPOL HS OIL or an equivalent good quality synthetic based 2-stroke engine oil.		
Engine oil tank capacity	1.0 ℓ		
Engine oil discharge amount	2.6 ~ 2.8 ml (at 3,000rpm for 5 minutes)		
Transmission oil type	SAE 10W/30 or 10W/40 multi - grade motor oil		
Transmission oil capacity	Change	80 ml	
	Overhaul	90 ml	

WIRE AND CABLE ROUTING

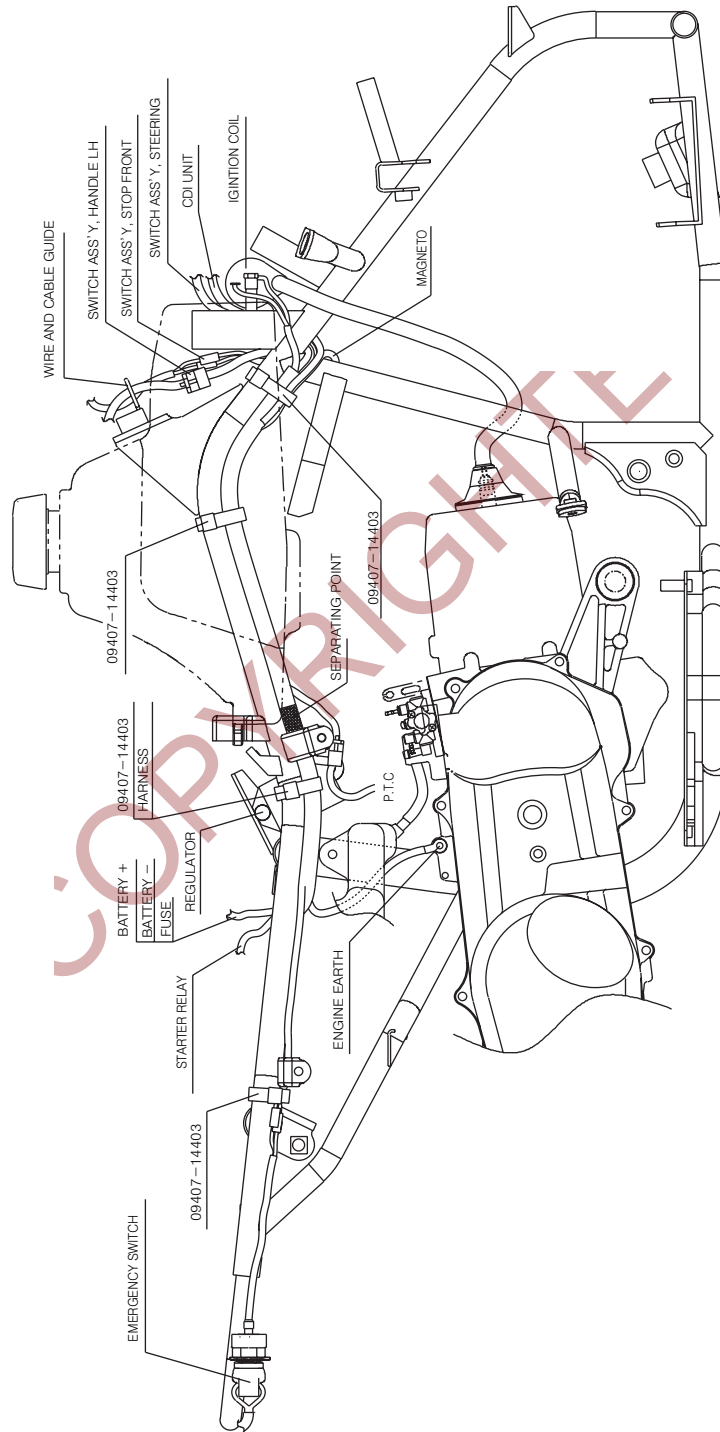

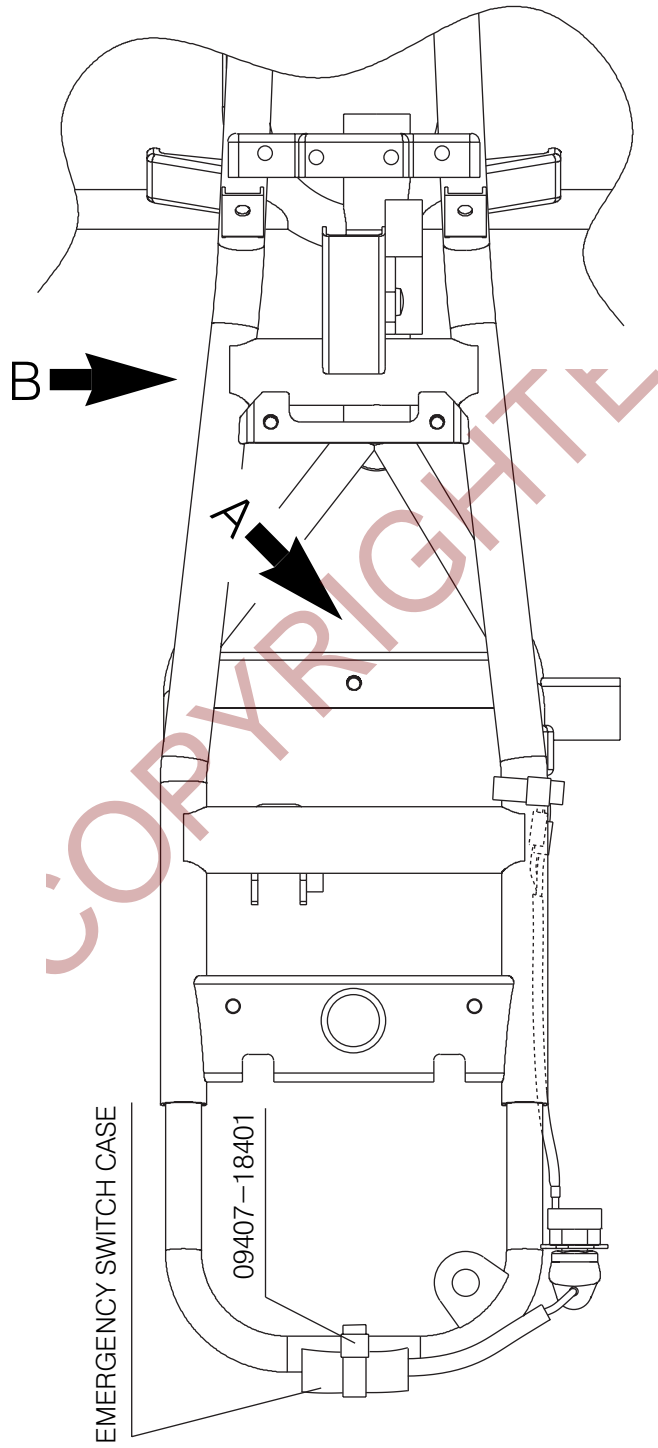

VIEW A

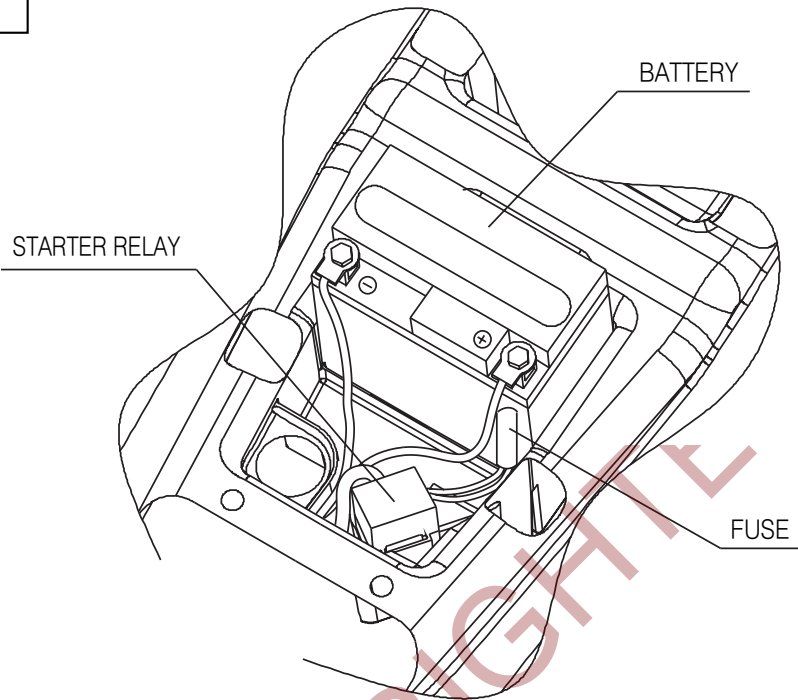

VIEW B

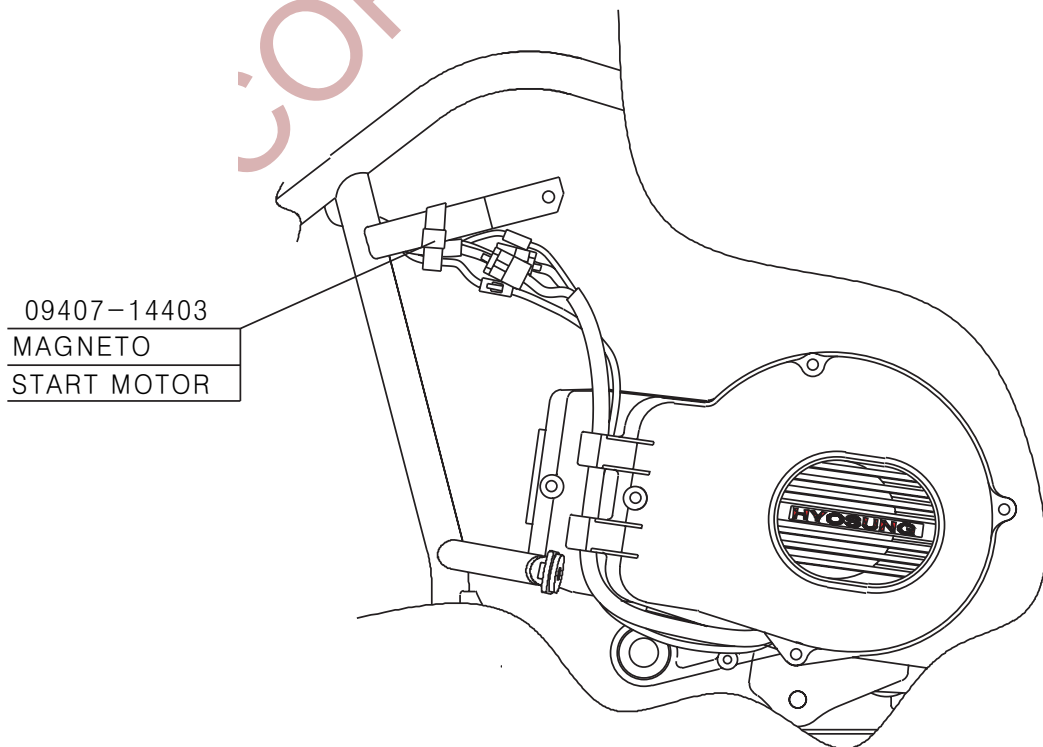

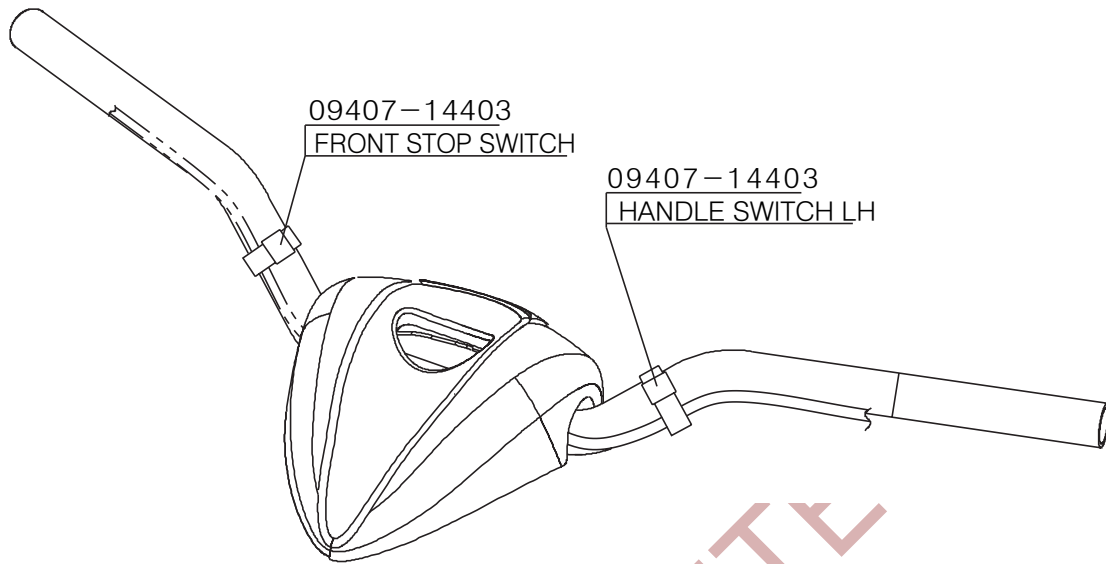

HANDLE SWITCH LH / STOP SWITCH

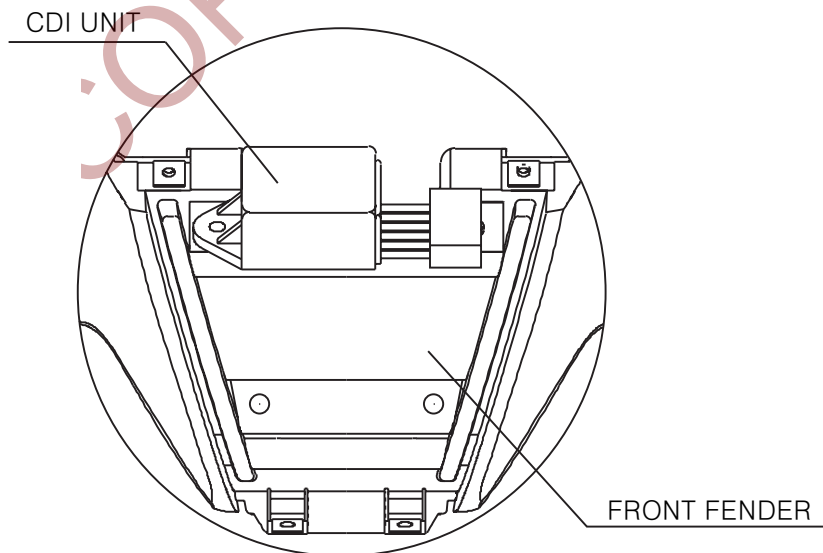

CDI UNIT ASSEMBLY POSITION

WIRING DIAGRAM

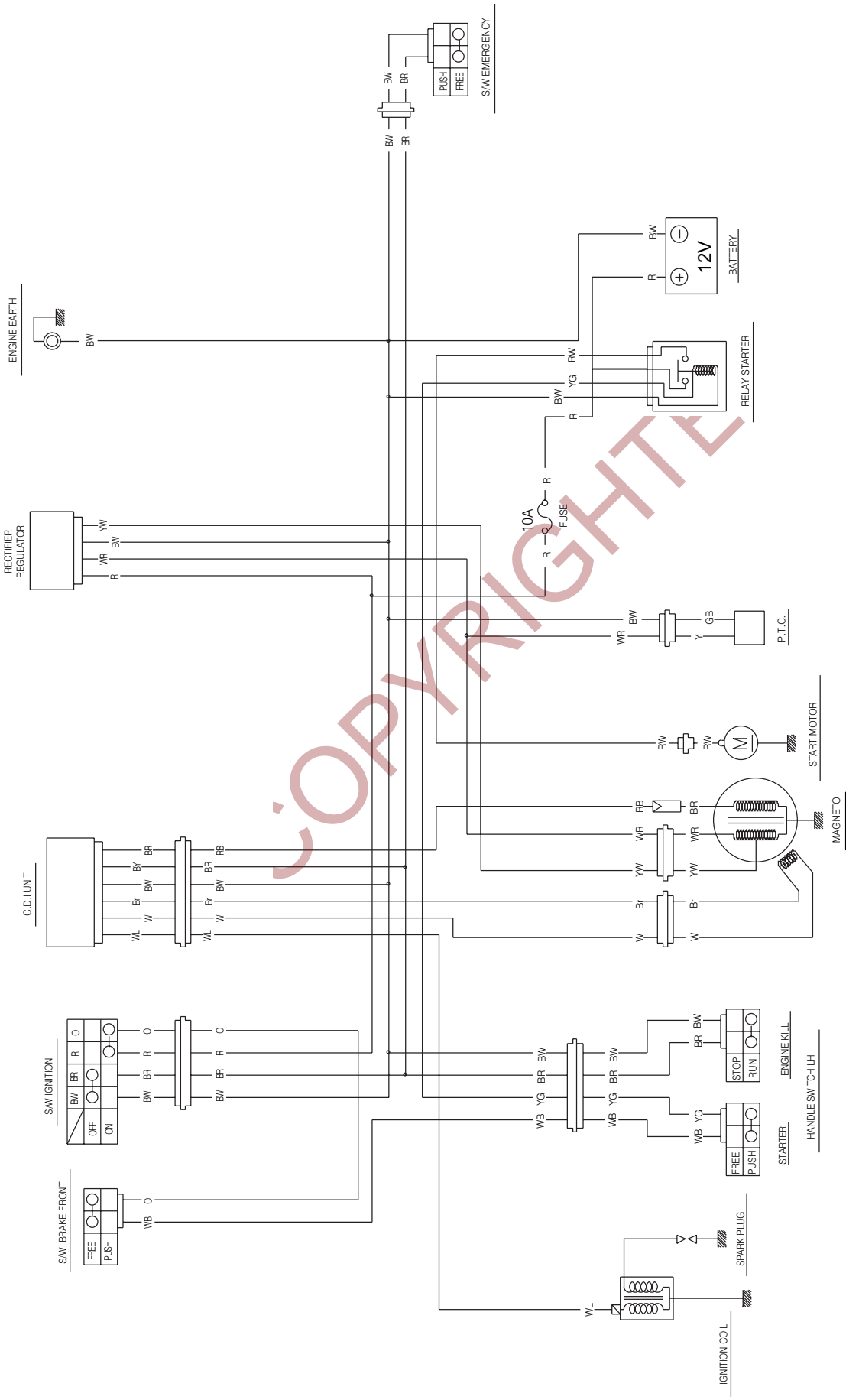

- WIRE COLOR**
- B : Black
 - Br : Brown
 - G : Green
 - Gr : Gray
 - L : Blue
 - Lg : Light green
 - O : Orange
 - R : Red
 - Sb : Light blue
 - W : White
 - Y : Yellow
 - BG : Black with Green tracer
 - BW : Black with White tracer
 - BR : Black with Red tracer
 - LW : Blue with White tracer
 - YG : Yellow with Green tracer
 - RB : Red with Black tracer
 - RW : Red with White tracer
 - WB : White with Black tracer
 - WR : White with Red tracer
 - YB : Yellow with Black tracer



Prepared by

HYOSUNG MOTORS & MACHINERY INC.

Overseas Technical Department

1st Ed. AUG. 2001.

Manual No. 99000-94310

Printed in Korea