



OWNER'S MANUAL

Karion

HYOSUNG MOTORS & MACHINERY INC.



1st Ed.

Part No. 99011HM5410
SEP. 2002.
Printed in KOREA

This manual should be considered a permanent part of the motorcycle and should remain with the motorcycle when resold or otherwise transferred to a new owner or operator. The manual contains important safety information and instructions which should be read carefully before operating the motorcycle.

FOREWORD

THANK YOU for choosing **Hyosung** motor cycle. We at **Hyosung** have designed, tested and produced this motorcycle using the most modern technology available to provide you with much happy, enjoyable, safe riding. Motorcycling is one of the most exhilarating sports and insure your riding enjoyment, you should become thoroughly familiar with the information presented in this Owner's Manual before riding the motorcycle.

The proper care and maintenance that your motorcycle requires are outlined in this manual.

By following these instructions explicitly you will insure a long trouble-free operating life for your motorcycle. Your **Hyosung** dealer has experienced technicians that are trained to provide your machine with the best possible service with the right tools and equipment.

All information, illustrations photographs and specifications contained in this manual are based on the latest product information available at the time of publication. Due to improvements or other changes, there may be some discrepancies in this manual. Hyosung reserves the right to make changes at any time.

Please note that this manual applies to all specifications for all respective destinations and explains all equipments. Therefore, your model may have different standard features than shown in this manual.

 **HYOSUNG MOTORS & MACHINERY INC.**
Overseas Technical Department

© COPYRIGHT HYOSUNG MOTORS & MACHINERY INC.

IMPORTANT

BREAK-IN INFORMATION FOR YOUR MOTORCYCLE

The first 1,000km(600miles) are the most important in the life of your motorcycle .

Proper break-in operation during this time will help ensure maximum life and performance from your new motorcycle.

Hyosung parts are manufactured of high quality materials, and manufactured parts are finished to close tolerances. Proper break-in operation allows the machined surfaces to polish each other and mate smoothly.

Motorcycle reliability and performance depend on special care and restraint exercise during the break-in period. It is especially important that you avoid operating the engine in a manner which could expose the engine parts to excessive heat.

Please refer to the BREAK-IN section for specific break-in recommendations.

WARNING/CAUTION/NOTE

Please read this manual and follow its instructions carefully. To emphasize special information the words 『WARNING』, 『CAUTION』 and 『NOTE』.



WARNING

The personal safety of the rider may be involved. Disregarding this information could result in injury to the rider.



CAUTION

These instructions point out special service procedures or precautions that must be followed to avoid damaging the machine.

NOTE

This provides special information to make maintenance easier or important instructions clearer.

 **WARNING****Noise Control System(muffler assembly)****TAMPERING WITH NOISE CONTROL SYSTEM PROHIBITED**

Owners are warned that the law may prohibit :

- (a) The removal or rendering inoperative by any person other than for the purpose of maintenance, repair or replacement, of any device or element of design incorporated into any new vehicle for the purpose of noise control prior to its any sale or delivery to the ultimate purchaser or while it is in use ; and
- (b) The use of the vehicle after such device or element of design has been removed or rendered inoperative by any person.

MAINTENANCE:

The exhaust system of this motorcycle requires no periodic maintenance. The engine should be adjusted to the manufacture' s specifications and the spark plug should be kept in good condition. Running the engine with incorrectly operating spark plug or misadjusted carburetor may cause permanent damage to the catalyst and to the noise control system.

CONSUMER INFORMATION

SAFE RIDING RECOMMENDATION FOR MOTORCYCLE RIDERS

Motorcycle riding is great fun and an exciting sport. Motorcycle riding also requires that some extra precautions be taken to ensure the safety of the rider and passenger. These precautions are:



WARNING

- Before first use of the 「*Karion*」, read this owner's manual carefully to become familiar with the 「*Karion*」's features, and safety and maintenance requirements. Review all instructions, requirements and warnings with the riders. Keep the owner's manual in the owner's manual storage compartment located under the seat.
- Before the rider's first use of the 「*Karion*」, make sure that he/she is familiar with the location and operation of all controls, and has been instructed in the proper operation of the motorcycle.
- For first use of the 「*Karion*」, find a level, open area for the rider to use to become familiar with the operation of controls and the operating and handling characteristics of the 「*Karion*」.



WARNING

- Before each use, perform daily inspections with the rider. Specific items to check are listed in the INSPECTION BEFORE RIDING section on page 36 of this owner's manual.
- Make sure the rider wears a helmet, eye protection, and protective clothing (gloves, leather or heavy cloth pants, long sleeved shirt or jacket, boots).
- Permit use only by a two rider. This motorcycle is designed for use only by a two rider.
- Do not permit anyone to operate the 「*Karion*」 under the influence of alcohol or other drugs caused by damage to the motorcycle or altered handling characteristics.
- Observe periodic maintenance requirements your authorized HYOSUNG dealer is trained and equipped to perform this service.
- Drain gasoline from the fuel tank and carburetor prior to transporting the 「*Karion*」.
- Caution the rider and others near the 「*Karion*」 not to get close to or touch any moving parts or any heated areas such as the engine and exhaust system.
- Do not make any modifications to the 「*Karion*」. Modifications may make the motorcycle unsafe or illegal in your state.

WARNING

The **「Karton」** comes equipped with a side stand safe device. This safe device is returned by itself. Push the side stand until it is in contact with the ground.

CAUTION

This motorcycle always come on the headlamp when starting engine.

WARNING

- Do not run the engine indoors or where there is little or no ventilation. Exhaust gases contain carbon monoxide, a potentially lethal gas that is colorless and odorless.
- Never leave the motorcycle running while unattended, even for a short time.

WARNING

While operating the **「Karton」**, the rider should keep both feet on the footrests at all times, or injuries resulting from accidents Moving the rider's feet from the footrests reduces the rider's ability to control the motorcycle, and could lead to an accident.

WARNING

Keep both hands on the handgrips at all times when riding. Removing your hands from the handgrips reduces your ability to control the motorcycle, and could result in an accident.

WARNING

Always open the throttle gradually to prevent front wheel lifting. Failure to observe this precaution may result in loss of control and an accident.

CAUTION

WHEN KEEPING FOR LONG PERIOD :

1. Drain the fuel in the fuel tank.
2. Do the fuel cock in the "OFF" position.
3. Do drain wholly the fuel in the carburetor.
4. Remove the battery from the motorcycle.

⦿ WEAR A HELMET

WARNING

Motorcycle safety equipment starts with a quality safety helmet. One of the most serious injuries that can happen is a head injury. **ALWAYS** wear a properly approved helmet. You should also wear a suitable eye protection.

⦿ RIDING APPAREL

WARNING

Loose fancy clothing can be uncomfortable and unsafe in terms of riding your motorcycle. Choose good quality motorcycle riding apparel in terms of riding your motorcycle.

⦿ INSPECTION BEFORE RIDING

WARNING

Review thoroughly the instructions in the “INSPECTION BEFORE RIDING” section of this manual. Do not forget to perform an entire safety inspection to ensure the safety of the rider and its passenger.

⦿ FAMILIARIZE YOURSELF WITH THE MOTORCYCLE

WARNING

Your riding skill and mechanical knowledge form the foundation for safe riding practices.

We suggest that you practice riding your motorcycle in a non-traffic situation until you are thoroughly familiar with your machine and its controls. Remember practice makes perfect.

⦿ KNOW YOUR LIMITS

WARNING

Ride within the boundaries of your own skill at all times. Knowing these limits and staying within them will help you to avoid accidents.

⦿ BE EXTRA SAFETY CONSCIOUS ON BAD WEATHER DAYS

WARNING

Riding on bad weather days, especially wet ones, requires extra caution. Braking distances double on a rainy day. Stay off of the painted surface marks, manhole covers and greasy appearing areas as they can be especially slippery.

Use extreme caution at railway crossings and on metal gratings and bridges. Whenever you have a doubt about road condition, slow down!

CONSUMER INFORMATION

ACCESSORY INSTALLATION AND PRECAUTION SAFETY TIPS

There are a great variety of accessories available to **Hyosung** owners. **Hyosung** can not have direct control over the quality or suitability of accessories you may wish to purchase except genuine parts.

The addition of unsuitable accessories can lead to unsafe operating conditions. It is not possible for **Hyosung** to test each accessory on the market or combinations of all the available accessories, however, your dealer can assist you in selecting quality accessories and installing them correctly.

Use extreme caution when selecting and installing the accessories for your **Hyosung**. We have developed some general guidelines which will aid you when deciding whether, and how to equip your motorcycle.

1. In case that additional weight or aerodynamic affecting accessories are installed, they should be mounted as low as possible, as close to the motorcycle and as near the center of gravity as is feasible. The mounting brackets and other attachment hardware should be carefully checked to ensure that it provides for a rigid, nonmovable mount. Weak mounts can allow the shifting of the weight and create a dangerous, unstable condition.
2. Inspect for proper ground clearance and bank angle. An improperly mounted load could critically reduce these two safety factors. Also

determine that the “load” does not interfere with the operation of the suspension steering or other control operations.

3. Accessories fitted to the handlebars or the front fork area can create serious stability problems. This extra weight will cause the motorcycle to be less responsive to your steering control. The weight may also cause oscillations in the front end and lead to instability problems. Accessories added to the machine should be as light as possible and kept to a minimum.
4. The motorcycle may be affected by a lifting condition or by an instability in cross winds or when being passed or passing large vehicles. Improperly mounted or poorly designed accessories can result in an unsafe riding condition, therefore caution should be used when selecting and installing all accessories.
5. Certain accessories displace the rider from his or her normal riding position. This limits the freedom of movement of the rider and may limit his or her control ability.
6. Additional electrical accessories may damage the existing electrical system. Severe overloads may damage the wiring harness or create a dangerous situation due to the loss of electrical power during the operation of the motorcycle.

When carrying a load on the motorcycle, mount it as low as possible and as close as possible to the machine. An improperly mounted load can create a high center of gravity which is very dangerous and makes the motorcycle difficult to handle. The size of the “load” can also affect the aerodynamics and handling of the

motorcycle.

Balance the load between the left and right side of the motorcycle and fasten it securely.



WARNING

Modification of the motorcycle, or removal of original equipment may render the vehicle unsafe or illegal.

TABLE OF CONTENTS

1. SERIAL NUMBER LOCATION	12
2. FUEL AND OIL RECOMMENDATION	12
FUEL	
ENGINE OIL	
3. NAMES OF EACH PARTS	14
4. CONTROLS	17
IGNITION SWITCH	
IGNITION KEY	
INSTRUMENT PANEL	
LEFT HANDLE SWITCH	
RIGHT HANDLE SWITCH	
CARBURETOR CHOKE LEVER	
FUEL COCK	
REAR BRAKE PEDAL	
KICK START LEVER	
GEARSHIFT LEVER	
STAND	
SEAT LOCK	
REAR SUSPENSION	
5. SUPPLY OF GASOLINE AND ENGINE OIL	25
GASOLINE	
ENGINE OIL	
6. RIDING TIPS	30
STARTING THE ENGINE	
STARTING OFF	
USING THE TRANSMISSION	
RIDING ON HILLS	
STOPPING AND PARKING	

7. BREAK-IN	34
8. INSPECTION BEEORE RIDING	36
9. PERIOPIC MAINTENANCE	36
10. INSPECTION AND REPAIR	39
TOOL	
ENGINE OIL	
GASOLINE	
RUBBER CAP OF CABLES	
EXHAUST PIPE AND MUFFLER	
FRONT FORK	
REAR SHOCK ABSORBER	
BATTERY	
AIR CLEANER	
FUEL HOSE	
SPARK PLUG	
CARBURETOR	
CLUTCH ADJUSTMENT	
DRIVE CHAIN	
BRAKES	
TIRE	
REPLACEMENT OF THE LAMP	
WHEN THE ENGINE REFUSES TO START	
WHEN KEEPING FOR LONG PERIOD	
CLEAN PROCEDURE	
11. LABEL	58
12. SPECIFICATIONS	60

SERIAL NUMBER LOCATION

The frame and/or engine serial numbers are used to register the motorcycle. They are also to assist your dealer in terms of ordering parts or referring to special service information.

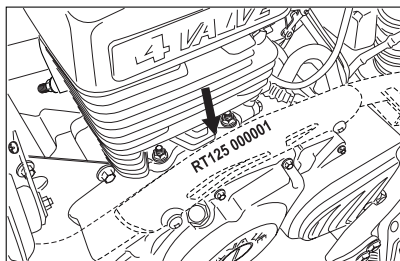
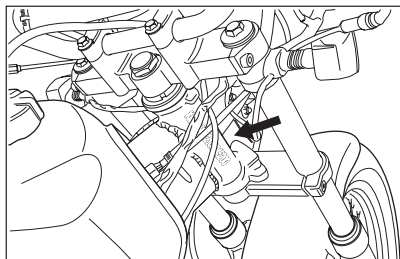

The frame number ① is stamped on the steering head tube.

The engine serial number ② is stamped on the left upside of the crankcase assembly.

Please write down the numbers in the box provided below for your future reference.

Frame number :

Engine number :

FUEL AND OIL RECOMMENDATION

FUEL

Use unleaded gasoline with an octane rating 85-95 or higher.

Unleaded gasoline can extend spark plug life and exhaust components life.

⚠ CAUTION

Spilling gasoline can damage the pointed surfaces.

Be careful not to spill any fuel when filling the fuel tank.

Wipe spilled gasoline up immediately.

⚠ WARNING

- When refueling, always shut the engine off and turn the ignition key to the "OFF" position. Never refuel near the flames, sparks and heat sources.
- Do not overfill the fuel tank. Do not fill the fuel tank above the entrance lower end.

ENGINE OIL

■ ENGINE OIL SPECIFICATION

Classification system	Grade	Remarks
API	Over SG	
SAE	10 W/30 or 10W/40	

※ If a SAE 10 W/30 or 10W/40 motor oil is not available, select an alternative according to the following chart.

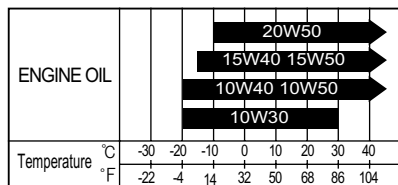

Using a premium quality four stroke motor oil will increase the service life of your motorcycle.



WARNING

- Don't mix the unrecommended oil. It could damage the engine.
- When refilling the oil tank, don't allow the dust to get inside.
- Mop the oil spilt.
- Don't put the patch on the cap. It could disturb the oil to be provided and damage the engine.

NAMES OF EACH PARTS

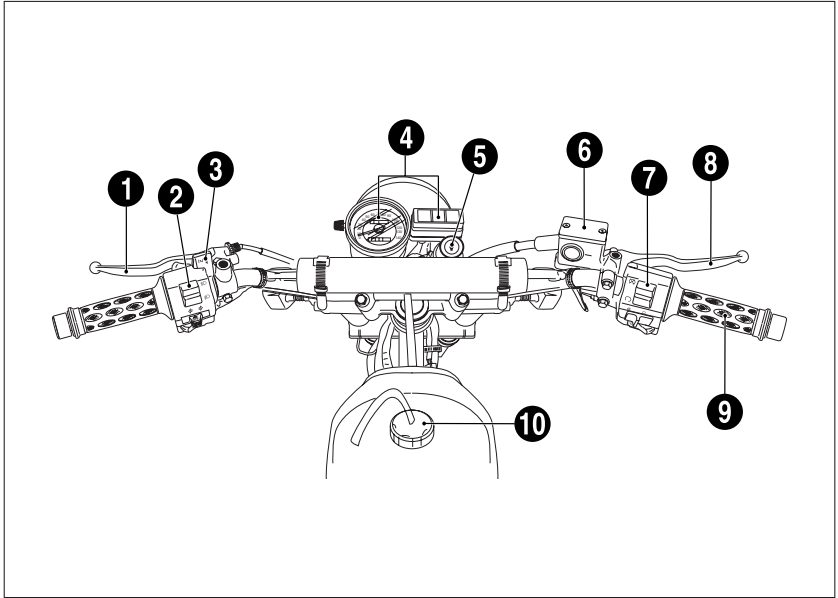

- ① Clutch lever
- ② Left handle switches
- ③ Choke lever
- ④ Speedometer
- ⑤ Ignition switches

- ⑥ Front brake fluid reservoir
- ⑦ Right handle switches
- ⑧ Front brake lever
- ⑨ Throttle grip
- ⑩ Fuel tank cap

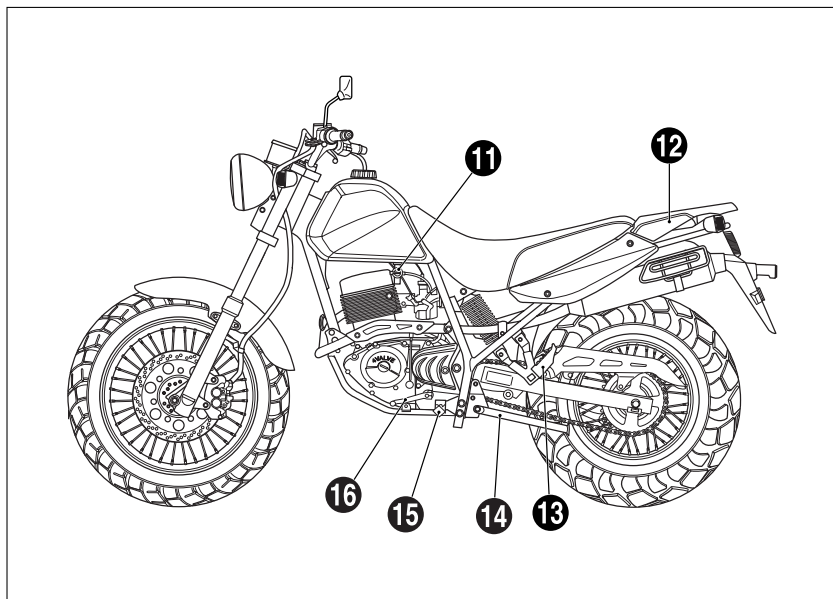

- ⑪ Fuel cock
- ⑫ Rear carrier
- ⑬ Passenger footrests
- ⑭ Side stand
- ⑮ Footrests
- ⑯ Gearshift lever

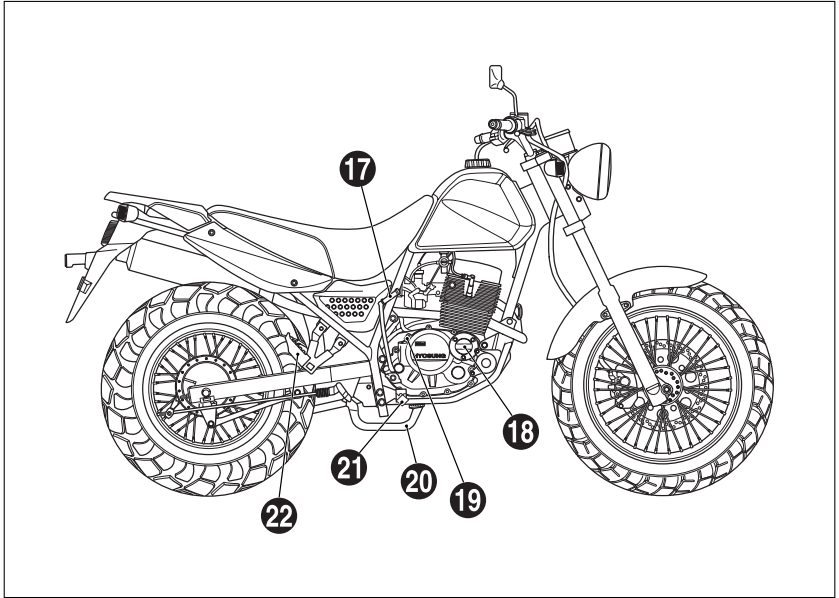

- ⑰ Kick starter lever
- ⑱ Engine oil filter cap
- ⑲ Engine oil filler cap & level gauge
- ⑳ Rear brake pedal
- ㉑ Footrests
- ㉒ Passenger footrests

CONTROLS

IGNITION SWITCH

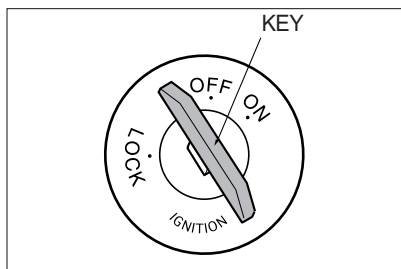

The ignition switch has three positions:

⊙ “OFF” POSITION

All electrical circuits are cut off.

The engine will not start. The key can be removed.

⊙ “ON” POSITION

The ignition circuit is completed and the engine can now be started. The key cannot be removed from the ignition switch in this position.

⊙ “LOCK” POSITION

To lock the steering, turn the handlebar all the way to the left. Push down the key to the “OFF” position and turn it to the “LOCK” position after come up again and remove the key.

All electrical circuits are disconnected.

IGNITION KEY

『*Karion*』 comes equipped with a pair of identical ignition keys. Keep the spare key in a safe place.

Your motorcycle ignition keys are stamped with an identifying number. This number is used when making replacement keys. Please write your key number in the box provided for your future reference.

Key number:

INSTRUMENT PANEL

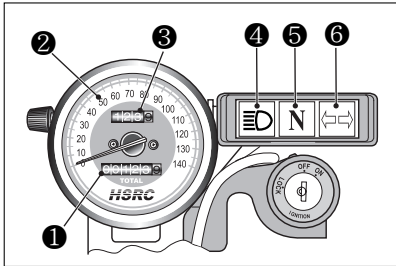

① ODOMETER

The odometer registers the total distance that the motorcycle has been ridden.

② SPEEDOMETER

The speedometer indicates the road speed in kilometers and miles per hour.

③ TRIP METER

The trip meter is a resettable odometer located in the speedometer assembly. It can be used to indicate the distance traveled on short trip or between fuel stops. Pressing control button will return the meter to zero.

④ HIGH BEAM INDICATOR LAMP

The high beam indicator lamp will come on when the headlamp high beam is turned on.

⑤ NEUTRAL INDICATOR LAMP

The neutral indicator lamp will come on when the transmission is in neutral.

The lamp will go out when you shift into any gear other than neutral.

⑥ TURN SIGNAL INDICATOR LAMP

When the turn signals are being operated either to the right or to the left, the indicator will flash at the same time.

LEFT HANDLE SWITCH

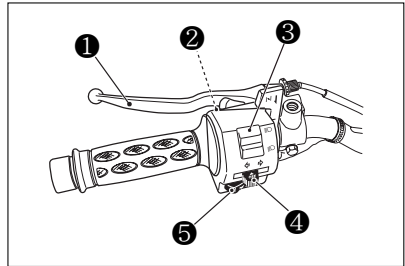

① CLUTCH LEVER

The clutch lever is used for disengaging the drive to the rear wheel when starting the engine or shifting the transmission gear.

Squeezing the lever disengages the clutch.

② “PASS” SWITCH



Press the “PASS” switch to operate the head lamp high beam for using when pass.

⚠ CAUTION

Not operate when the dimmer switch “” position.

③ DIMMER SWITCH

Change direction of headlamp light.

- “” : The headlamp high beam and taillamp come on.
The high beam indicator lamp also comes on.
- “” : The headlamp low beam and taillamp come on.

WARNING

Set the dimmer switch “

④ TURN SIGNAL SWITCH

Using when left, right turn or change direction.

- “

CAUTION

Always use the turn signals when you intend to change lanes or make a turn. Always be sure to turn the turn signal switch to the “OFF” position after completing the turn or lane change.

⑤ HORN SWITCH

Press the switch to operate the horn.

RIGHT HANDLE SWITCH

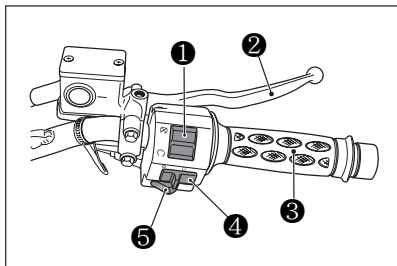

① ENGINE STOP SWITCH

- “

WARNING

Do not operate for the engine stop switch is in the “

② FRONT BRAKE LEVER

The front brake is applied by squeezing the brake lever gently toward the throttle-grip.

Front brake be anxious about motorcycle falling down when braking suddenly as disk brake system. The brake lamp will come on when the lever is squeezed.



WARNING

Apply the brake lightly and with great care on slippery surfaces to avoid skidding.

③ THROTTLE GRIP

Engine speed is controlled by position of the throttle grip. Turn it toward you to increase engine speed. Turn it away from you to decrease the engine speed.



WARNING

Avoid turning the throttle grip during brakes.

④ LIGHT SWITCH

- ⦿ “” position

The meter lamp and taillamp come on.

- ⦿ “○” position

The meter lamp and taillamp go off.



CAUTION

This motorcycle always come on the headlamp when starting the engine.

⑤ STARTER SWITCH

Use this switch to operate the starting motor.

With the ignition switch in the “ON” position, the engine stop switch in the “○” position, and the transmission is in neutral, pull in the clutch lever and push the starter switch to start the engine.



CAUTION

Do not engage the starting motor for more than five seconds at a time as it may overheat the wiring harness and starting motor.

If the engine does not start after several attempts, check the fuel supply and ignition system.

(Refer for Page 56)

CARBURETOR CHOKE LEVER

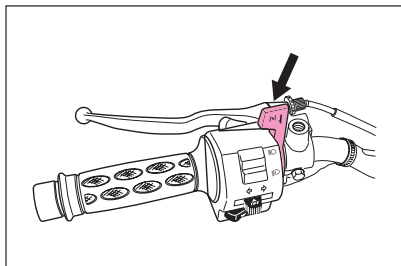

The carburetor is equipped with a choke system to provide easy starting when the engine is cold.

When starting the cold engine, turn the choke lever all the way toward you. The choke works best when the throttle is in the closed position. When the engine warm, you do not need to use the choke system for starting.

CAUTION

If keep running in condition that full choke lever, cause in fuel excess exhaustion, high speed not running, it may damage of ignition plug.

FUEL COCK

『*Karton*』 is equipped with a manually operated fuel cock.

There are three position : "ON", "OFF" and "RES".

☉ "ON" Position

The normal operating position for the fuel cock lever is in the "ON" position.

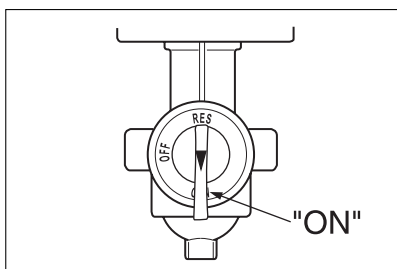

☉ "OFF" Position

Turn the lever to the "OFF" position whenever stopping the engine for more than a few minutes.

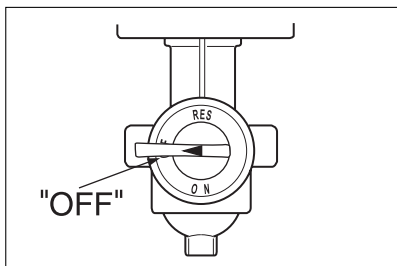

⊙ “RES” (RESERVE) Position

If the fuel level in the tank is too low, turn the lever to the “RES” position to use the 1.5 ℓ of reserve fuel supply.

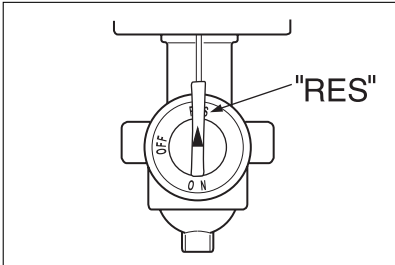

※ Confirm the each mark by “△” mark at the fuel cock lever.

⚠ CAUTION

After switching the fuel cock lever to the “RES” position, it is advisable that the tank be refilled at the closest gas station. After refueling be sure to move the fuel cock to the “ON” position.

REAR BRAKE PEDAL

Depressing the rear brake pedal will apply the rear brake.

The brake lamp will be illuminated when the rear brake is operated.

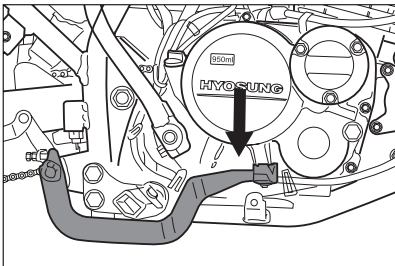

⚠ WARNING

Apply the brake lightly and with great care on slippery surfaces to avoid skidding.

KICK START LEVER

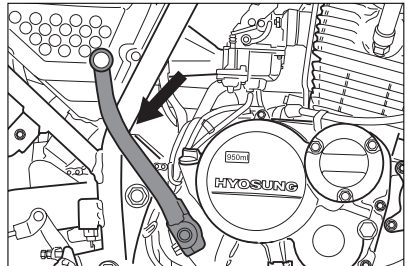

The kick start lever be exist at right side of the engine.

This engine is possible starting any position of gear after pulling clutch lever as primary kick start type.

⚠ CAUTION

When started the engine, check that kick start lever return to normal position.

⚠ WARNING

When start by kick start lever, pay attention to position of a foot. It should be contacted with footrest lever, be will injured.

GEARSHIFT LEVER

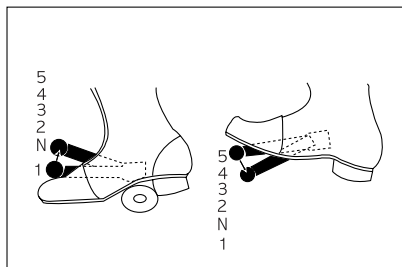
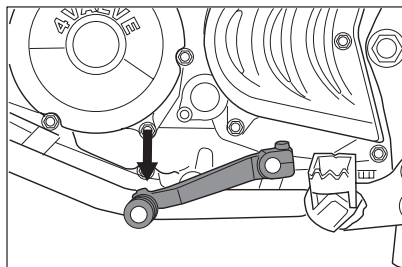

『*Kartoo*』 has a 5-speed transmission which operates as shown.

To shift properly, pull the clutch lever and close the throttle at the same time you operate the gearshift lever. Each time that a gear is selected, the gearshift lever will return to its normal position ready to select the next gear.

Lift the gearshift lever to upshift and depress the lever to downshift.

Neutral is located between first and 2nd gear.

When neutral is desired, depress or lift the lever halfway between first and 2nd gear.

It is not possible to upshift or downshift more than one gear at a time.

When shifting from first to 2nd gear or 2nd gear to low, neutral will be automatically skipped.

Reduce the motorcycle speed before down-shifting.

When down-shifting, the engine speed should be increased before the clutch is engaged.

This will prevent unnecessary wear on the drive train components and the rear tire.

⚠ CAUTION

When the transmission is in neutral the green indicator lamp on the instrument panel will be lit.

However, even though the light is illuminated, cautiously release the clutch lever slowly to determine whether the transmission is positively in neutral.

STAND

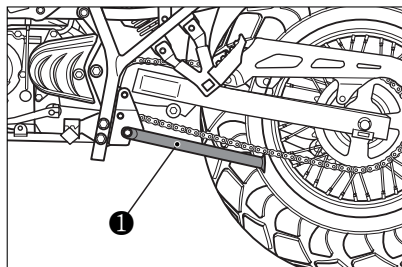

① Side stand



WARNING

The 「*Karton*」 comes equipped with a side stand safe device.
This safe device is returned by itself.
Push the side stand until it is in contact with the ground.

SEAT LOCK

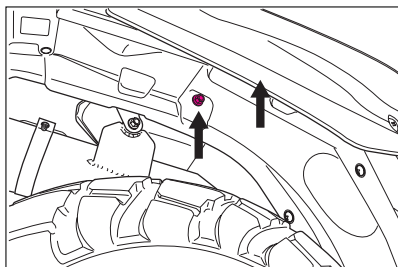

To separate the seat, loosen two bolts that are united the rear fender and the frame below the seat.

When assemble the seat, put up the seat at the frame and unite two bolts.

REAR SUSPENSION

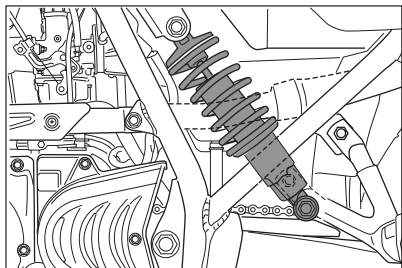

To adjust the spring pre-load, turn the adjuster clockwise or counter-clockwise to the desired position with the pin spanner.

Position 1 provides the softest spring pre-load and position 5 provides the stiffest.

『*Kartan*』 is delivered from the factory with its adjuster set on position 1.

SUPPLY OF GASOLINE AND ENGINE OIL

GASOLINE

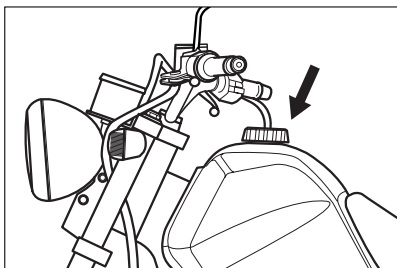

To open the fuel tank cap, remove the end of vent tube from the vehicle body and turn fuel tank cap counter-clockwise. To close the fuel tank cap, turn it clockwise and tighten it securely.

WARNING

Do not overfill the fuel tank. Stop adding fuel when the fuel level reaches the bottom of the filler neck. If you fill the tank beyond this level, fuel may overflow when it expands due to engine heat or heating by the sun.



WARNING

Gasoline is extremely flammable and toxic. Always observe the following precautions when refueling your *Kartan*.

- Never permit motorcycle refueling by anyone other than an adult.
- Refuel in a well ventilated area.
- Make sure the engine is off and avoid spilling fuel on a hot engine.
- Do not smoke, and make sure there are no open flames or sparks in the area.
- Avoid prolonged contact with skin and breathing of gasoline vapors.
- Keep children and pets away during refueling.

ENGINE OIL

Long engine life depends much on the selection of quality oil and the periodic changing of the oil.

Daily oil level checks and periodic changes are two of the most important maintenances to be performed.

⊙ ENGINE OIL LEVEL CHECK

Follow the procedure below to inspect the engine oil level.

1. Start the engine and run it for a few minutes.
2. Stop the engine and wait three minutes.
3. Hold the motorcycle vertically and inspect the engine oil level through the engine oil filler plug on the right side on the engine.
4. Mop the engine oil level gauge when did engine oil inspected.

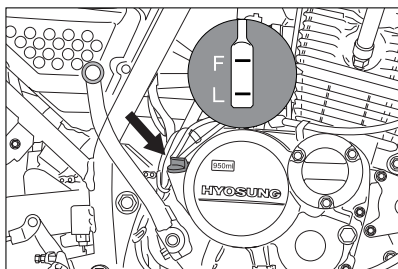

⚠ CAUTION

“Fuel and Engine oil” use certainly to recommend at the front part.

CAUTION

Never operate the motorcycle if the engine oil level is below the “Lower line mark(L)” in the engine oil level gauge. Never fill the engine oil above the “Upper line mark(F)”. Engine oil level being most suitable about 1mm under the “Upper line mark(F)” of the engine oil level gauge. In case of the engine oil pouring excessively, the engine output being made insufficient.

Be careful not to pour the engine oil excessively.

⊙ ENGINE OIL AND FILTER CHANGE

Change the engine oil and filter, after first running 1,000km and every running 4,000km.

The oil should always be changed when the engine is hot so that the oil will drain thoroughly from the engine. The procedure is as follows.

ENGINE OIL CAPACITY

Replace	950 ml
Oil filter replace	1,050 ml
Overhaul	1,400 ml

CAUTION

In case of the engine oil pouring excessively, the engine output being made insufficient.

Be careful not to pour the engine oil excessively.

1. Place the motorcycle on the jack or block.

CAUTION

More frequent servicing may be performed on motorcycles that are used under severe conditions, inspect ① Quantity of Engine oil, ② Pollution degree of Engine oil before riding the motorcycle and then supplement and replace at any time to prevent damage of the engine.

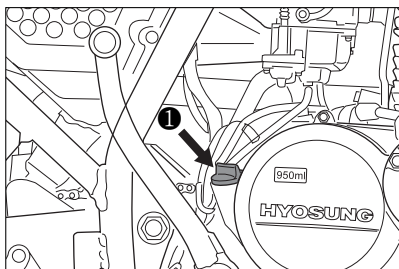

2. Remove the engine oil filler cap ①.

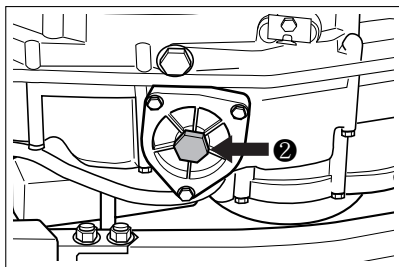

CAUTION

Necessarily, confirm and clean the oil strainer (A) when replace the Engine oil(specially, when first replacement).

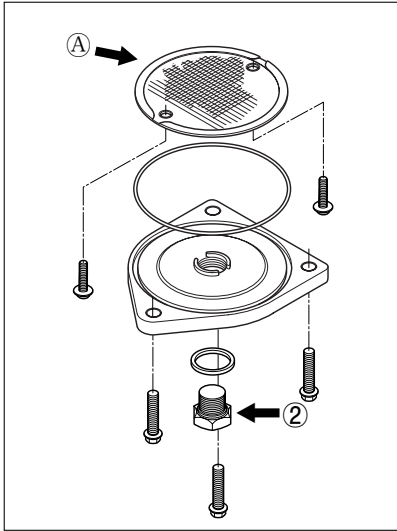

3. Drain the oil by removing the drain plug ② located on the bottom of the engine.

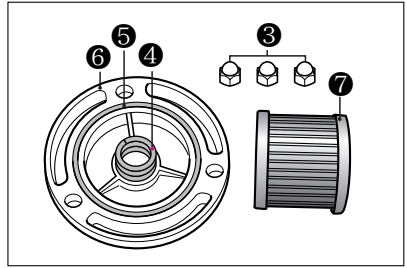
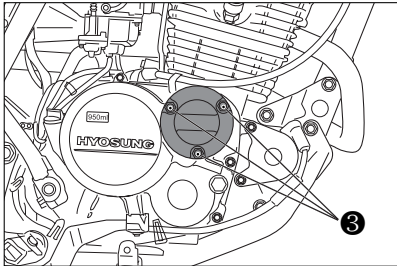

⚠ CAUTION

Insert the filter so that surface of the filter hole turn toward the engine.

● OIL FILTER INSTALLATION

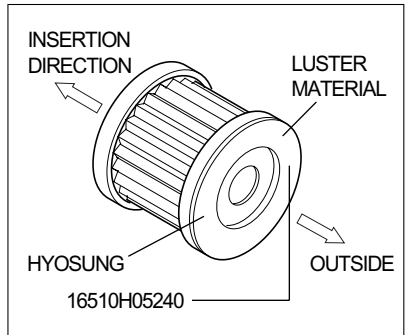

⚠ CAUTION

When install the oil filter, necessarily, “HYOSUNG” character and “16510H05240” part's NO. install toward the outside, otherwise can damage the engine.



WARNING

Engine oil and exhaust pipes can be hot enough to burn you.

Wait until the oil drain plug and exhaust pipes are cool enough to touch with bare hands before draining oil.



WARNING

New and used oil and solvent can be hazardous. Children and pets may be harmed by swallowing new or used engine oil or solvent. Continuous contact with used engine oil has been found to cause skin cancer in laboratory animals. Brief contact with used oil or solvent may irritate skin.

- Keep new and used oil and solvent away from children and pets.
- Wear a long-sleeve shirt and waterproof gloves.
- Wash with soap if oil or solvent contact your skin.

4. Remove the three nuts ③ holding the filter cap ⑥ in place.
5. Replace the engine oil filter ⑦ with a new one.
6. Before replacing the engine oil filter cover, be sure to check that the engine oil filter spring ④ and the “O” ring ⑤ are installed correctly. Use new “O” ring each time the engine oil filter element is replaced.
7. Replace the oil filter cover and tighten the nuts securely but do not over tighten them.



CAUTION

Approximately 950ml of oil must be required when changing oil only without replacing the oil filter.

8. Replace the drain plug and tighten it securely. Pour fresh oil through the filler hole. Approximately 1,050ml of oil will be required.



CAUTION

In case of the engine oil pouring excessively, the engine output being made insufficient.

Be careful not to pour engine oil.

9. Operate the engine a few seconds by idling speed.
Inspect to leak oil at the oil filter cap.
10. Confirm the oil level with the oil level gauge after waiting about a minute next to stopping the engine.

The oil level is located between the “Lower line(L)” and the “Upper line(F)”.

When below the “Lower line(L)”, refill the oil between the “Lower line(L)” and the “Upper line(F)”.

RIDING TIPS

STARTING THE ENGINE

Before attempting to start the engine make sure:

1. The transmission is in neutral.
2. The fuel cock lever is in the "ON" position.
3. The engine stop switch is in the "○" position.
4. Inspect every day once before riding the motor cycle.

⊙ When the engine is cold :

1. Turn the carburetor choke lever all the way toward you.
2. Close the throttle grip and push the starter switch.
3. Immediately after the engine starter return the choke lever halfway and warm up the engine.
4. Return the choke lever all the way to its disengaged position.

⊙ When the engine is warm :

1. Open the throttle grip 1/8 ~ 1/4.
2. Push the starter switch.

CAUTION

Operation of the carburetor choke system is not necessary when the engine is warm.

WARNING

Running the engine indoors or in a garage can be hazardous. Exhaust gas contains carbon monoxide, a gas that is colorless and odorless and can cause death or severe injury. Only run the engine outdoors where there is a fresh air.

CAUTION

Running the engine too long without riding may cause the engine to overheat. Overheating can result in damage to internal engine components and discoloration of exhaust pipes. Shut the engine off if you cannot begin your ride promptly.

CAUTION

This motorcycle always come on the headlamp when starting the engine.

STARTING OFF

WARNING

Riding this motorcycle at excessive speed increases your chances of losing control of the motorcycle.

This may result in an accident.

Always ride within the limits of your skills, your motorcycle, and the riding conditions.

WARNING

Removing your hands from the handlebars or feet from the footrests during operation can be hazardous. If you remove even one hand or foot from the motorcycle, you can reduce your ability to control the motorcycle.

Always keep both hands on the handlebars and both feet on the footrests of your motorcycle during operation.

WARNING

Sudden side winds, which can occur when being passed by large vehicles, at tunnel exits or in hilly areas, can upset your control.

Reduce your speed and be alert to side winds.

After moving the side stand to the fully upper position, pull the clutch lever in and pause momentarily. Engage first gear by depressing the gearshift lever downward.

Turn the throttle grip toward you and at the same time release the clutch lever gently and smoothly. As the clutch engages, the motorcycle will start moving forward. To shift to the next higher gear, accelerate gently, then close the throttle and pull the clutch lever in simultaneously. Lift the gearshift lever upward to select the next gear and release the clutch lever and open the throttle again.

Select the gears in this manner until fifth gear is reached.

WARNING

Downshifting while the motorcycle is leaned over in a corner may cause rear wheel skid and loss of control.

Reduce your speed and downshift before entering corner.

WARNING

The *» Karion «* comes equipped with a side stand safe device.

This safe device is returned by itself.

Push the side stand until it in contact with the ground.

USING THE TRANSMISSION

The transmission is provided to keep the engine operating smoothly in its normal operating speed range. The gear ratios have been carefully chosen to meet the characteristics of the engine. The rider should always select the most suitable gear for the prevailing conditions.



WARNING

Downshifting when engine speed is too high can ;

- **cause the rear wheel to skid and lose traction due to increased engine braking, resulting in an accident ; or**
- **force the engine to overrev in the lower gear, resulting in engine damage.**

Reduce speed before downshifting.

RIDING ON HILLS

When climbing steep hills, the motorcycle may begin to slow down and show lack of power. At this point you should shift to a lower gear so that the engine will again be operating in its normal power range. Shift rapidly to prevent the motorcycle from losing momentum.

When riding down a steep hill, the engine may be used for braking by shifting to a lower gear.

Be careful, however, not to allow the engine to overrev.

STOPPING AND PARKING

1. Turn the throttle grip away from you to close the throttle completely.
2. Apply the front and rear brakes evenly and at the same time.
3. Downshift through the gears as road speed decreases.
4. Select neutral with the clutch lever squeezed towards the grip (disengaged position) just before the motorcycle stops. Neutral position can be confirmed by observing the neutral indicator lamp.

WARNING

Inexperienced riders tend to underutilize the front brake. This can cause excessive stopping distance and lead to a collision. Using only the front or rear brake can cause skidding and loss of control.

Apply both brakes evenly and at the same time.

WARNING

Hard braking while turning may cause wheel skid and loss of control.

Brake before you begin to turn.

WARNING

Hard braking on wet, loose, rough, or other slippery surfaces can cause wheel skid and loss of control.

Brake lightly and with care on slippery or irregular surfaces.

WARNING

The *Kartion* comes equipped with a side stand safe device.

This safe device is returned by itself.

Push the side stand until it in contact with the ground.

WARNING

Following another vehicle too closely can lead to a collision. As vehicle speeds increase, stopping distance increases progressively.

Be sure you have a safe stopping distance between you and the vehicle in front of you.

5. Park the motorcycle on a firm, flat surface where it will not fall over.

WARNING

A hot muffler can burn you. The muffler will be hot enough to burn you for some time after stopping the engine.

Park the motorcycle where pedestrians or children are not likely to touch the muffler.

6. Push down the key to the "OFF" position, and turn it to the "LOCK" position after come up again.
7. Remove the ignition key.

BREAK-IN

The opening explains how important proper break-in is to achieve maximum life and performance from your new **Hyosung**. The following guidelines explain proper break-in procedures.

★ MAXIMUM THROTTLE OPENING RECOMMENDATIONS

The table below shows the maximum throttle opening recommendation during the break-in period.

Initial 800km (500miles)	Less than 1/2 throttle
Up to 1,600km (1,000miles)	Less than 3/4 throttle

★ VARY THE ENGINE SPEED

The engine speed should be varied and not held at a constant speed.

This allows the parts to be “loaded” with pressure and then unloaded, allowing the parts to cool.

This aids the mating process of the parts. It is essential that some stress be placed on the engine components during break-in to ensure this mating process.

Do not, though, apply excessive load on the engine.

★ BREAKING IN THE NEW TIRES

New tires need proper break-in to assure maximum performance, just as the engine does.

Wear in the tread surface by gradually increasing your cornering lean angles over

the first 160km(100miles) before attempting maximum performance. Avoid hard acceleration, hard cornering, and hard braking for the first 160km(100miles).



WARNING

Failure to perform break-in of the tires could cause tire slip and loss of control. Use extra care when riding on new tire. Perform proper break-in of the tire as described in this section and avoid hard acceleration, hard cornering, and hard braking for the first 160km(100miles).

★ ALLOW THE ENGINE OIL TO CIRCULATE BEFORE RIDING

Allow sufficient idling time after warm or cold engine start up before applying load or reviving the engine. This allows time for the lubricating oil to reach all critical engine components.

★ OBSERVE YOUR FIRST, AND MOST 1,000km SERVICE

The 1,000km (600miles) service is the most important service your motorcycle will receive.

During break-in procedures all of the engine components will have worn in and all of the other parts will have seated in.

All adjustments will be restored, all fasteners will be tightened, and the dirty engine oil and engine oil filter will be replaced.

Timely performance of the 1,000km (600miles) service will ensure optimum service life and performance from the engine.

 **CAUTION**

Service should may be performed before 1,000km(600miles) on motorcycle that are used under severe conditions.

 **CAUTION**

The 1,000km (600miles) service should be performed as outlined in the INSPECTION AND MAINTENANCE section of this Owner's Manual. Pay particular attention to the 『CAUTION』 and 『WARNING』 in that section.

INSPECTION BEFORE RIDING

Before riding the motorcycle, be sure to check the following item.

Inspect every day once them before riding the motorcycle.

- Abnormal point of the previous day.
- Extra braking power of the brake lever.
- Fluid measure of the master cylinder.
- Pressure, crack, cut, strange wear, foreign substance (stone, nail and others) of Tire.
- Adequate tread depth of Tire.
- Fluid measure of Engine oil.
- Pollution degree inspection of Engine oil.
- Fluid measure of Fuel.
- On and off condition or damage of Lamp, turn signal lamp and others.
- Condition of rear-view mirror.
- Loosening of spoke nipple

PERIODIC MAINTENANCE

The chart indicates the intervals between periodic service in kilometers.

At the end of each interval, be sure to inspect, check, lubricate and service as instructed.

If your motorcycle is used under high stress conditions such as continuous full throttle operation, or is operated in a dusty climate, certain services should be performed more often to ensure reliability of the machine as explained in the maintenance section.

Your **Hyosung** dealer can provide you with further guide lines.

Steering components, suspensions and require very special and careful servicing. For maximum safety we suggest that you have these items inspected and serviced by your authorized **Hyosung** dealer or a qualified service mechanic.

⊙ LUBRICATION POINTS

Proper lubrication is important for smooth and long life of each working part of your motorcycle and also for safe riding. It is a good practice to lubricate the motorcycle after a long rough ride or after it gets wet in the rain or after washing it.

Major lubrication points are indicated as follows.



WARNING

Improper maintenance or failure to perform recommended maintenance increases the chance of an accident or motorcycle damage.



CAUTION

Using poor quality replacement parts can cause your motorcycle to wear more quickly and may shorten its useful life.

Use only genuine Hyosung replacement parts or their equivalent.

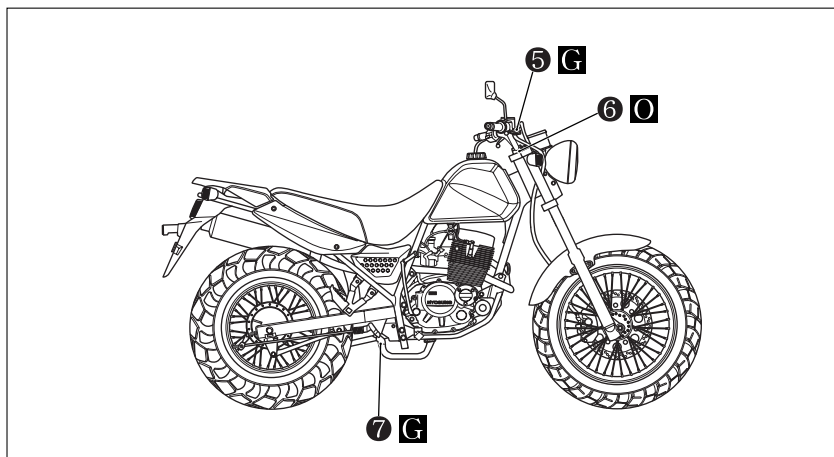
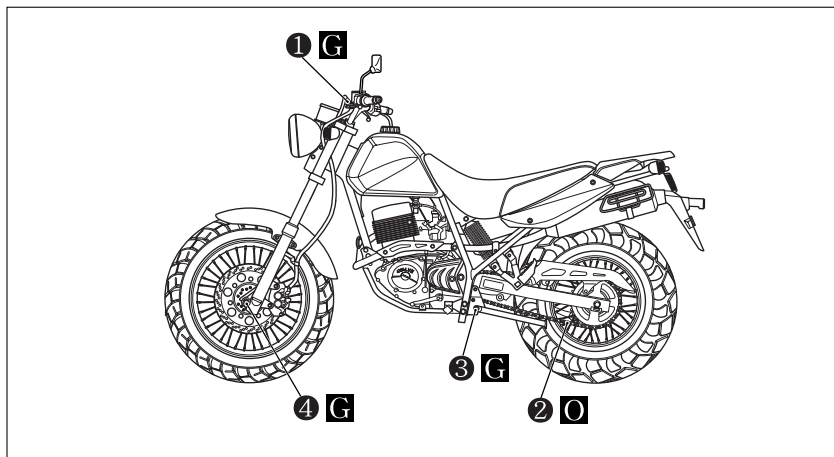

① Clutch lever holder

② Drive chain

③ Side stand pivot and spring hook

④ Speedometer gear box

⑤ Brake lever holder

⑥ Throttle cable

⑦ Brake pedal pivot

○ - Motor oil □ - Grease

⊙ ENGINE

Item \ Interval	First 1,000 km	Every 4,000 km	Every 8,000 km
Air cleaner element	Clean every 3,000 km · Replace every 12,000 km		
Exhaust pipe bolts and muffler mounting bolts ★	Tighten	Tighten	—
Valve clearance adjust ★	Inspect	Inspect	—
Cylinder head nut ★	Tighten	Tighten	—
Cylinder head & Cylinder ★	—	—	Remove carbon
Spark plug	Clean	Clean	Replace
Fuel hose	Inspect	Inspect	—
	Replace every 4 years		
Engine oil filter	Replace	Replace	—
Engine oil	Replace	Replace	—
Throttle cable	Inspect	Inspect	—
Idle speed ★	Inspect	Inspect	—
Clutch ★	Inspect	Inspect	—

⊙ CHASSIS

Item \ Interval	First 1,000 km	Every 4,000 km	Every 8,000 km
Drive chain ★	Clean and lubricate every 1,000 km		
Brake ★	Inspect	Inspect	—
Brake hose ★	Inspect	Inspect	—
	Replace every 4 years		
Brake fluid ★	Inspect	Inspect	—
	Replace every 2 years		
Tire	Inspect	Inspect	—
Steering ★	Inspect	Inspect	—
Front forks ★	—	Inspect	—
Rear shock absorber ★	—	Inspect	—
Chassis nuts and bolts ★	Tighten	Tighten	—

NOTE

★ = Ask your Hyosung dealer or qualified mechanic to do the maintenance items marked.

INSPECTION AND REPAIR

TOOL

To assist you in the performance of periodic maintenance, a tool kit is supplied and is located under the right side cover. The tool kit consists of the following items.

NO.	NAME
1	Tool bag
2	10 × 12 mm open end wrench
3	12 × 14 mm open end wrench
4	Spark plug wrench
5	Combination screw driver
6	Screw driver handle
7	Pliers

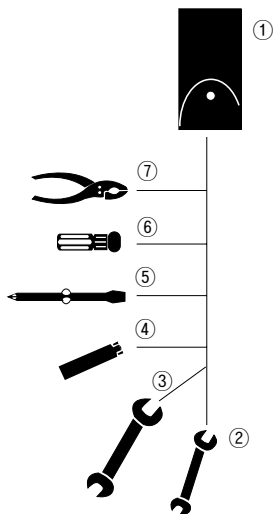

ENGINE OIL

Check if there is leakage from crankcase, oil hose.

GASOLINE

Check if there is leakage from fuel tank, fuel cock, hose, carburetor.

RUBBER CAP OF CABLES

Mop them up with a patch when washing.

EXHAUST PIPE AND MUFFLER

Inspect the exhaust pipe and muffler joint for loosening.

FRONT FORK

- Check if there is any noise by bend of front fork while moving the handle upward and downward.
- Inspect whether the steering stem is well assembled while moving front fork up/downwards and /or forward/backward.

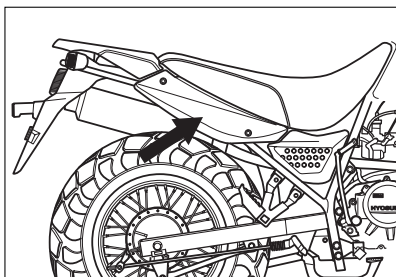

REAR SHOCK ABSORBER

Inspect the rear shock absorber for oil leakage and spring condition.

BATTERY

⊙ INSPECTION OF BATTERY SOLUTION LEVEL

MF(Maintenance Free) battery of airtight type is used for this motorcycle.

It is not necessary to inspect or supplement battery fluid.

The battery is located behind the right frame cover.

However, have your dealer check the charging condition of battery periodically.

⚠ CAUTION

- Do not remove absolutely airtight cover as airtight type battery.
- Keep after separate at the motorcycle for the minimum of self electric discharge and electric leakage when don't use for a long time.
- Remove the (-) negative terminal when keep intact at the motorcycle.

⊙ CLEAN OF BATTERY TERMINAL

Clean the battery terminal when it is dusty or rusted.

1. Set the ignition switch "OFF" position.
2. Disassemble the battery cover, disassemble the (+) positive battery wire after the (-) negative battery wire. Remove the battery.

3. Clean the terminal.

If there is white dust, clean it with warm water.

4. Assemble the battery wires and grease the terminal lightly.

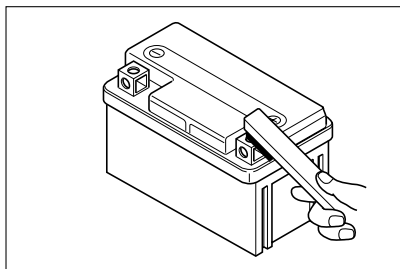

⚠ CAUTION

- Keep the battery away from fires.
- When disassemble the battery wire, take off ⊖ terminal first with the ignition switch "OFF" position. When assemble, ⊕ terminal first.
- Fasten certainly the battery wires.
- Incorrect installation of the battery will reverse the terminal position resulting in possible electrical system damage due to incorrect battery lead connection.
- Never charge a battery while still in the machine as damage may result to the battery or regulator/rectifier.

AIR CLEANER

If the air cleaner element has become clogged with dust, intake resistance will increase with a resultant decrease in power output and an increase in fuel consumption. If riding under severe conditions must be cleaned or replaced more frequently than maintenance schedule. Check and clean the air cleaner element periodically according to the following procedure.

⚠ CAUTION

If the air cleaner element is polluted, will occur to starting go out, output insufficiency, combustion efficiency decline, and sooty smoke(black smoke). This appearance is occurred at first to clean the air cleaner element and confirm.

1. Remove the seat and right side cover.
2. Remove the six screws ① and remove the case cover.
3. Take off the air cleaner element ②

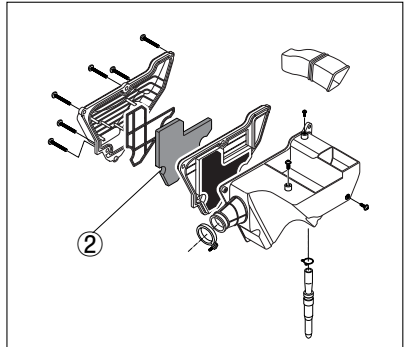
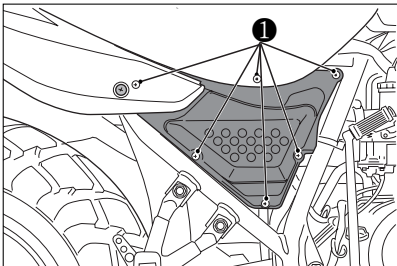

4. Fill a washing pan of a proper size with nonflammable cleaning solvent (A). Immerse the element in the cleaning solvent and wash it clean.
5. Squeeze the cleaning solvent out of the washed element by pressing it between the palms of both hands : do not twist or wring the element or it will develop tears.
6. Immerse the element in HYOSUNG genuine oil (B) and squeeze the oil out of the element leaving it slightly wet with oil.
7. Assemble the air cleaner element.

⚠ CAUTION

Before and during the cleaning operation, inspect the element for tears. A torn element must be replaced.

Be sure position the element snugly and correctly, so that no incoming air will bypass it.

Remember, rapid wear of piston rings and cylinder bore is often caused by a defective or poorly fitted element.

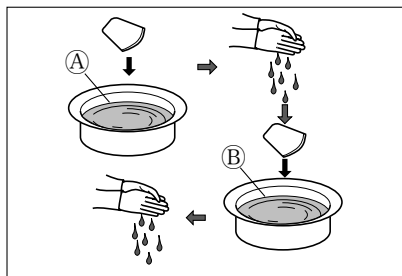

⚠ CAUTION

- Don't use the cleaning solvent whose flash point is low when cleaning the element.
- Assemble the element completely or damage severely the engine.
- Be careful not to allow water to go inside the air cleaner element.

⚠ CAUTION

- When the assembly of air cleaner element is not completely done, dusts can go inside and damage severely engine.
- Be careful not to allow water to go into the element while washing.

⚠ CAUTION

More frequent servicing may be performed on motorcycles that are used under severe conditions, also clean the air cleaner element when replacing the oil to prevent damage of the engine.

FUEL HOSE

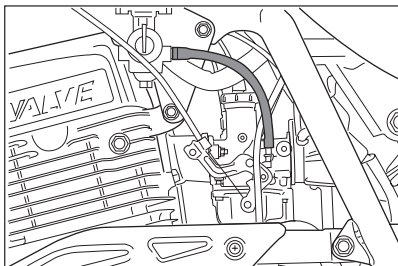

Inspect the fuel hose for damage and fuel leakage. If any defect are found the fuel hose must be replaced.

Replace the fuel hose every 4 years.

SPARK PLUG

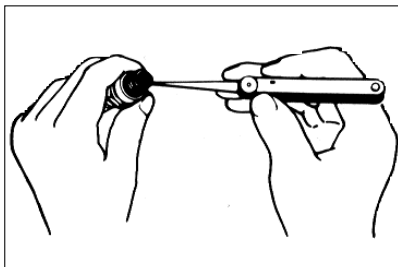

Remove the carbon deposits periodically from the spark plug with a piece of hard wire or pin.

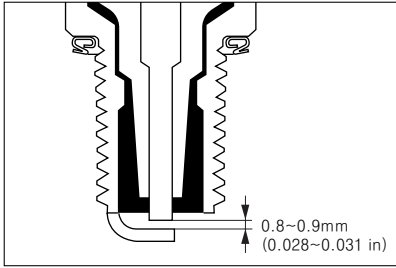

Readjust the spark plug gap to 0.8~0.9 mm (0.028~0.031 inch) by using a spark plug gap thickness gauge.

PLUG REPLACEMENT GUIDE

Hotter type	C7EH-9
Standard type	C8EH-9
Colder type	C9EH-9

⚠ CAUTION

- Do not over torque or cross thread the spark plug or the aluminum threads of the cylinder head will be damaged.
Do not allow contaminants to enter the engine through the spark plug holes when the plug is removed.
- The standard spark plug for this motorcycle has been carefully selected to meet the vast majority of all operational ranges. If the spark plug color indicates that other than a standard spark plug be used, it is best to consult your **Hyosung** dealer before selecting an alternate plug or heat range. The selection of an improper spark plug can lead to severe engine damage.

CARBURETOR

Undisturbed carburetion is the basis of the performance you ought to expect of your engine.

The carburetor is factory-set for the best carburetion.

Do not attempt to alter its setting.

There are two items of adjustment, however, under your care : engine idle speed and throttle cable play.

⊙ IDLING SPEED

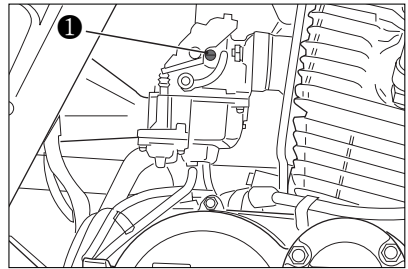

Start up the engine and let the engine run until it warms up fully.

After engine has warmed up, turn the throttle stop screw ① in or out so that the engine may run at 1,400~1,500 RPM.

⚠ CAUTION

The engine idle speed should be adjusted with the engine fully warm.

⊙ THROTTLE CABLE ADJUSTMENT

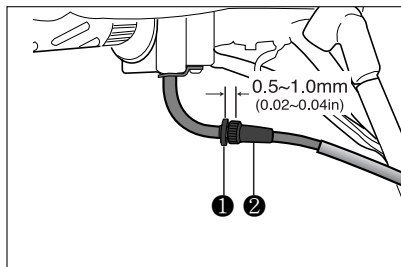

- (1) Loosen the lock nut ①.
- (2) Adjust the cable slack by cable adjuster ② in or out to obtain the correct slack 0.5~1.0mm(0.02~0.04in).
- (3) After adjusting the slack, tighten the lock nut.

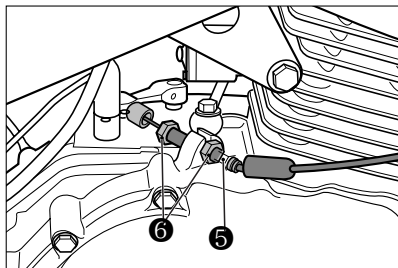
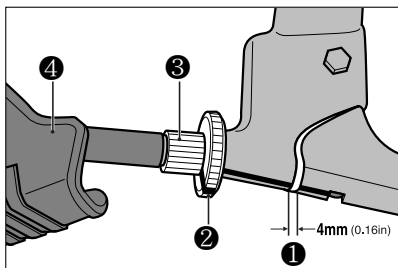

⚠ CAUTION

After completing throttle cable adjustment, check that handlebar movement does not raise the engine idle speed and that the throttle grip return smoothly and automatically.

- ① The clutch lever play
- ② The lock nut
- ③ The clutch lever adjuster
- ④ The rubber boot
- ⑤ The cable adjuster
- ⑥ The clutch cable adjuster lock nut

If you find the play of the clutch incorrect, adjust it in the following way :

CLUTCH ADJUSTMENT

At each maintenance interval, adjust the clutch cable play by means of clutch cable adjuster.

The cable play should be 4mm(0.16in) as measured at the clutch lever holder before the clutch begins to disengage.

⊙ CLUTCH CABLE

- (1) Loosen the lock nut ② and the clutch lever adjuster ③ turn all the way toward clockwise.
- (2) Loosen the clutch cable adjuster lock nut ⑥. Turn the cable adjuster ⑤ that the clutch lever play ① should be 4mm(0.16in)
- (3) A little adjustment be allowed by the clutch lever adjuster ③.
- (4) After end of adjustment, tighten the lock nut ②, ⑥ and cover the rubber boot ④.

DRIVE CHAIN

The chain may require more frequent adjustment than it is with periodic maintenance depending upon your riding conditions.

Check the chain every 1,000km.



WARNING

Riding with the chain in poor condition or improperly adjusted can lead to an accident.

Inspect, adjust, and maintain the chain properly before each ride, according to this section.

⊙ Inspecting the Drive Chain

When inspecting the chain, look for the following:

- Loose pins
- Damaged rollers
- Dry or rusted links
- Kinked or binding links
- Excessive wear
- Improper chain adjustment

If you find something wrong with the drive chain condition or adjustment, correct the problem if you know how. If necessary, consult your authorized **Hyosung** dealer.

Damage to the drive chain means that the sprockets may also be damaged. Inspect the sprockets for the following :

- Excessively worn teeth
- Broken or damaged teeth
- Loose sprocket mounting nuts

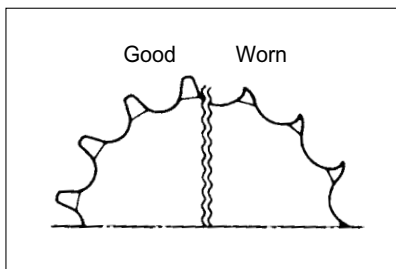

If you find any of these problems with your sprocket, consult your **Hyosung** dealer.



CAUTION

The two sprockets should be inspected for wear when a new chain is installed and replace them if necessary.

⊙ DRIVE CHAIN ADJUSTMENT

Chain adjust in the following way.

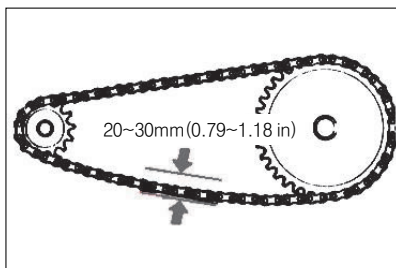
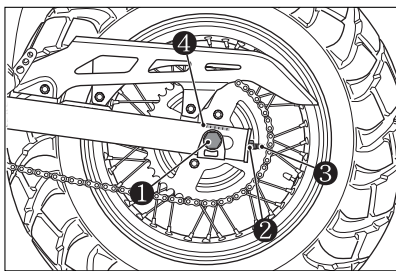

1. Place the motorcycle on the jack or block.
2. Loosen the axle nut ①.
3. Adjust the slack in the drive chain by adjuster ③ as the lock nut ② turning toward the left and right.
4. For alignment of the rear sprocket and the front sprocket, there are reference mark ④ on the same position.

After aligning and adjusting the slack in the drive chain to 20~30mm (0.79~1.18 in), retighten the axle nut securely and perform a final inspection.

Ⓞ DRIVE CHAIN CLEANING AND OILING

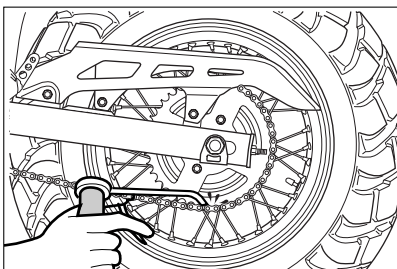

If the drive chain become dirty, the drive chain and the sprocket is wore easily. This times, clean the drive chain with solvent and oil every 1,000km with lubricating oil or motor oil.

⚠ CAUTION

The drive chain for this motorcycle is made of the special material.
The chain should be replaced with a 428HO.
Use of another chain may lead to premature chain failure.

⚠ CAUTION

The drive chain should be inspected every time before riding.
Excessive chain slack could cause the chain to come off the sprockets and result in accident or serious engine damage.

⚠ WARNING

Be careful not to touch the muffler when it is hot : a hot muffler can burn you.

BRAKES

Properly operating the brake systems are vital to safe riding. Be sure to perform the brake inspection requirements as schedules.

The brakes should be inspected at periodic inspection by your authorized Hyosung dealer.

⊙ FRONT BRAKE

● BRAKE FLUID

Be sure to check the brake fluid level in the master cylinder. If the level was found to be lower than the lower mark while holding the motorcycle upright, replenish with the proper brake fluid that meets Hyosung's requirements.

As the brake pads wear, the fluid level will drop to compensate for the new position of brake pads.

Replenishing the master cylinder is considered normal periodic maintenance.

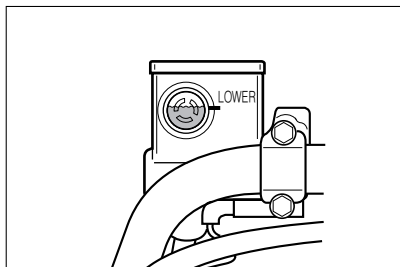

⚠ WARNING

Brake fluid may be harmful if swallowed or if it comes in contact with skin or eyes. Contact your doctor immediately if brake fluid is swallowed and induce vomiting. If brake fluid gets into the eyes or in contact with the skin, flush thoroughly with plenty of water.

⚠ CAUTION

This motorcycle uses glycol-based brake fluid. Do not use or mix different types of brake fluid such as silicone-based or petroleum-based fluid, otherwise serious damage will result in the brake system.

Use only DOT3 or DOT4. Do not spill any brake fluid on painted or plastic surfaces as it will damage the surface severely.

Never use any brake fluid that has been stored in a used or unsealed container. Never reuse brake fluid left over from the last servicing and stored for long period as it absorbs moisture from the air.

● BRAKE PADS

Inspect the front brake pads by noting whether or not the friction pads are worn down to the grooved limit line. If a pad is worn to the grooved limit line it must be replaced with a new one by your authorized Hyosung dealer or qualified service mechanic.

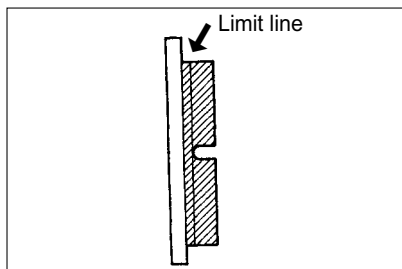
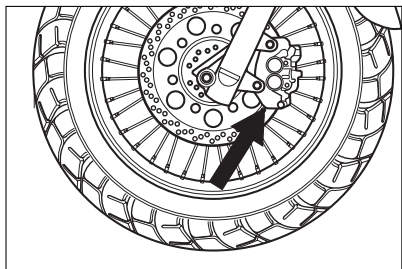

Inspect every day in the following point at the brake system.

- ① Brake fluid leak of the front brake system.
- ② Leak or damage of the brake hose.
- ③ Operating of the brake lever.
- ④ Wear of the front brake pads.

⚠ CAUTION

The front brake system be replaced the brake hose or the brake fluid according to periodic inspection chart by your authorized Hyosung dealer for safety as in times of operating at high pressure.

⚠ WARNING

Riding with worn brake pads will reduce braking performance and will increase your chance of having accident. Inspect brake pad wear before each use. Ask your Hyosung dealer or qualified mechanic to replace brake pads if any pad is worn to the limit.

⚠ CAUTION

After replaced the front brake pads, the brake lever pull and release several times so that it is setting at the original place.
Then, do not ride the motorcycle until operating the brake fluid and becoming the brake distance.

⊙ BRAKE DISK INSPECTION.

Check the brake disk for damage or cracks.

⊙ FRONT BRAKE FLUID SUPPLY

1. Place the motorcycle on a level surface and keep the handlebars straight.
2. Clean the brake fluid reservoir around not to allow dust to get inside of it.
3. Loosen the screw and open the cap.
4. Replenish with brake fluid to the upper line.

⚠ CAUTION

Do not spill any brake fluid on painted or plastic surfaces as it will damage the surface severely.

N O T E

The recommended brake fluid
: DOT3 or DOT4

5. Fasten the cap.

- ⊙ REAR BRAKE
- REAR BRAKE ADJUSTMENT

⚠ WARNING

Too much clearance in the rear brake pedal can cause poor braking performance and may lead to an accident. Too little clearance may force brake shoes to rub against the drum at all times, causing damage to the shoes and the drum.

Follow the steps in this section to adjust the rear brake pedal properly.

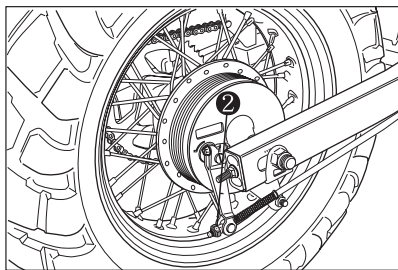
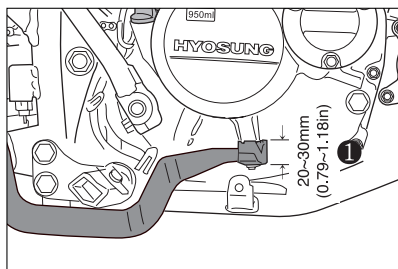

Adjust the free travel ① to 20~30 mm (0.79~1.18 in) by screwing in or out the brake adjusting nut ②.

● BRAKE LINING WEAR LIMIT

The motorcycle is equipped with the brake lining wear limit indicators on the rear brakes.

To check wear of the brake lining, perform the following :

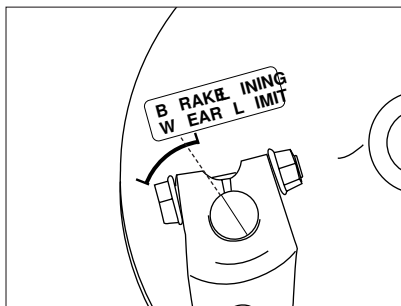

- ① Check if the brake system is properly adjusted.
- ② While fully applying the brake, check to see that the extension line of the index mark is within the range on the brake panel.
- ③ If the extension line is beyond the range, have the brake shoe assembly replaced by your Hyosung dealer to ensure safe operation.



WARNING

Riding with worn brake shoe will reduce braking performance and will increase your chance of having an accident. Inspect brake shoe wear before each use. Ask your Hyosung dealer or qualified mechanic to replace brake shoe if the shoes are worn to the limit.

● FRONT BRAKE LAMP SWITCH

The front brake lamp switch is located beneath the front brake lever. Loosen the switch fitting screws and adjust the timing by moving the switch body forward or backward.

● REAR BRAKE LAMP SWITCH

The rear brake lamp switch is located at right-side of the engine.

Move the switch up or down to adjust it until the switch operates and turns on the brake lamp after the brake pedal begins to be depressed.

TIRE

Inspect the tire pressure and the tire thread depth periodically.

Inspect frequently the tire pressure for the safety and the tire life.

⦿ TIRE PRESSURE

Insufficient air pressure in the tires not only hasten tire wear but also seriously affects the stability of the motorcycle.

Under-inflated tires make smooth cornering difficult and over-inflated tires decrease the amount of tire in contact with the ground which can lead to skids and loss of control. Be sure that the tire pressure is within the specified limits at all times.

Tire pressure should only be adjusted when the tire is cold.

If you see the problem with the tire, adjust the pressure with the pressure gauge.

TIRE PRESSURE (COLD INFLATION)	NORMAL RIDING	
	SOLO RIDING	DUAL RIDING
FRONT	1.25 kg/cm ²	1.50 kg/cm ²
	125 kpa	150 kpa
	18.0 psi	22.0 psi
REAR	1.25 kg/cm ²	1.75 kg/cm ²
	125 kpa	175 kpa
	18.0 psi	25.0 psi

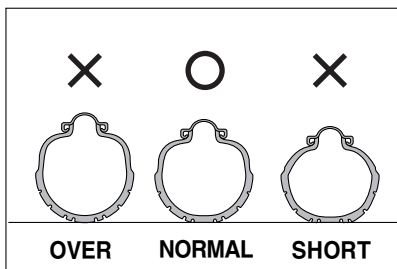

⚠ CAUTION

If there are some problem with the tire pressure or cracks and cuts, it will decrease the riding stability and lead to flat tire.

⦿ CRACKS AND CUTS

Check if

- 1) there are visible cracks and cuts.
- 2) there are pebbles stuck.

⦿ TIRE TREAD CONDITION

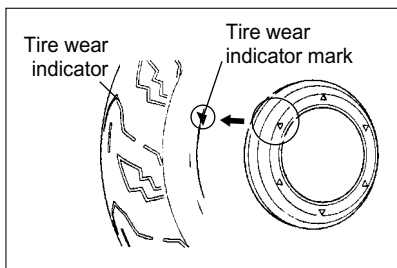

Operating the motorcycle with excessively worn tire will decrease riding stability and can lead to loss of control.

Inspect storage of tire thread's depth by the 『tire wear indicator』.

Replace the front and rear tires at once when appear the 『tire wear indicator』.

⊙ REAR AXLE NUT

Inspect the rear axle shaft and jointing nut for loosening.

⊙ SPOKE NIPPLE

Inspect the spoke nipple for loosening and retighten the spoke nipple in case of loosening.



WARNING

If the spoke nipple loose, it will increase damage of the spoke and rim and decrease the riding stability.

Spoke nipple tightening torque	0.25 ~ 0.30 kgf · m 2.5 ~ 3.0 N · m
--------------------------------	--

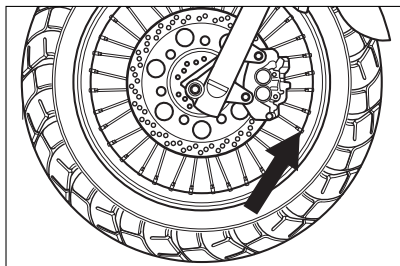

⚠ CAUTION

The standard tire on 『*Karion*』 is 130/80-18 66p for front, and 180/80-14M/C 78p for rear.

The use of a tire other than standard may cause trouble.

It is highly recommended to use the standard tire supplied by Hyosung.

REPLACEMENT OF THE LAMP

Requirement electric power of the lamp shown in the following chart.

When replace the damaged lamp, always use the equal capacity.

The use of a lamp other than rules may cause to excessive at the electric system or to damage the lamp.

NAMES		CAPACITY
Head lamp	HI	12V-35W × 1
	LO	12V-35W × 1
Brake / Tail lamp		12V-21/5W × 1
Turn signal lamp		12V-10W × 4
License lamp		12V-5W × 1

⊙ HEAD LAMP

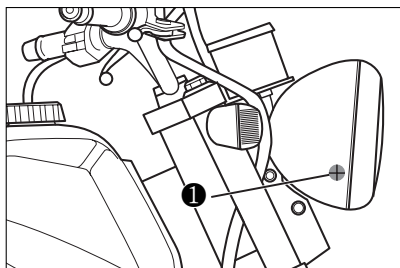

1. Remove the two screw ① (right and left) and the headlamp assembly.

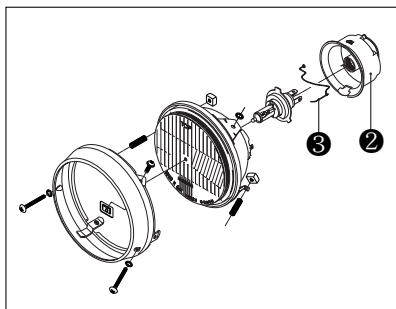

2. Disconnect the headlamp coupler.
3. Remove the dust cover ② and socket spring ③.
4. After removing the bulb at the socket, replace the new bulb.
5. To install the headlamp, reverse the above sequence.

⚠ CAUTION

The use of a lamp other than rules may cause to occur the vehicle fire and to damage electric parts.
Surely use only the lamp of proper capacity.

⊙ TURN SIGNAL LAMP

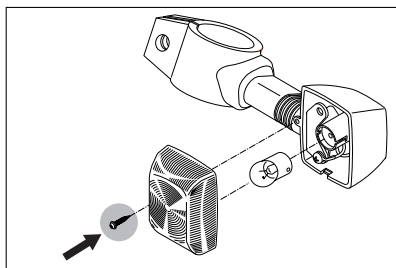

1. Remove the lens by removing the screw.

2. Push the bulb, turn it to the counter-clockwise, and pull it out.
3. After stick in the new lamp, assemble the lens.

⊙ TAIL/BRAKE LAMP

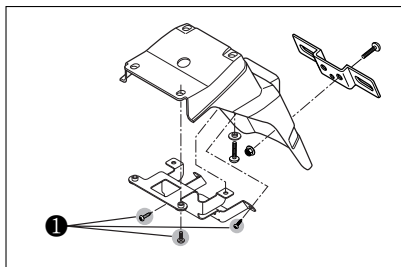

1. Remove the eight rear fender bracket mounting bolt ①.
2. Turn the socket to the counter-clockwise and pull it out at the lamp housing.

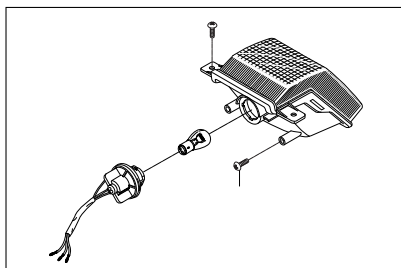

3. Push in the bulb, turn it to the counter-clockwise and pull it out.
4. To fit the replacement bulb, push it in and turn it to the clockwise while pushing.

⚠ CAUTION

Overtightening the screws may cause the lens to crack.

⊙ FUSE

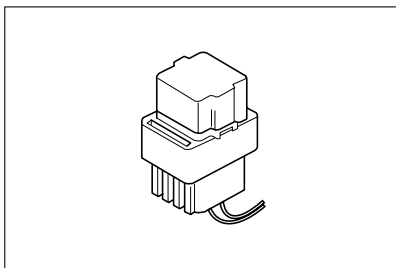

The fuse box is located behind the seat. If the engine suddenly stops while running or any electrical system fails to operate then the fuse must be checked.

In case a fuse blows there is a 15A spare fuse.

⚠ CAUTION

Never use other than specified 15A fuse. Installing a fuse of incorrect rating may seriously damage the electrical system. You should consult your Hyosung dealer or a qualified service mechanic immediately.

WHEN THE ENGINE REFUSES TO START

⊙ TROUBLE SHOOTING

If the engine refuses to start, perform the following inspections to determine the cause.

● Fuel Supply Check

- ① Is there enough fuel in the fuel tank?
- ② Is the fuel reaching the carburetor from the fuel cock?
- ③ Disconnect the fuel line from the carburetor, turn the fuel cock to the "ON" position and see if gasoline flows from the hole.
- ④ If it has been determined that fuel is reaching the carburetor, the ignition system should be checked next.

⚠ CAUTION

Do not allow the fuel to spill. Catch the fuel in container. Do not allow any fuel to come in contact with the hot engine or exhaust system. Extinguish any smoking materials before performing this check, and stay away from any other fire or heat source.

● Ignition System Check

- ① Remove a spark plug and reattach to the spark lead.
- ② While holding the spark plug firmly against the engine, crank the engine with the ignition switch in the "ON" switch.

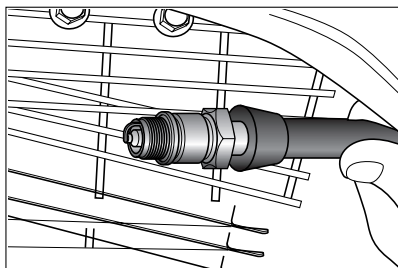

⚠ WARNING

Do not hold the spark plug close to the open spark plug hole in the cylinder head as gasoline vapor inside the cylinder should be ignited, creating a fire hazard.

● Engine Starting

- ① Check the fuel supply in the fuel tank.
- ② Check the ignition system for intermittent spark.
- ③ Check the engine idle speed.

⚠ CAUTION

When occur any trouble, the best way is to consult your Hyosung dealer for repairs.

WHEN KEEPING FOR LONG PERIOD

1. Drain the fuel in the fuel tank.
2. Do the fuel cock in the "OFF" position.
3. Do drain wholly the fuel in the carburetor.
4. Remove the battery from the motorcycle.

CLEANING PROCEDURE

A thorough cleaning of your motorcycle is a necessary part of maintenance and will help keep your motorcycle looking and performing its best. Proper cleaning can also extend the life of your motorcycle.

It is important to clean and inspect your motorcycle after every ride if it is used in mud, brush, grass, water, salt water, or very dusty conditions.

The build-up of mud, brush, grass, etc, especially on the engine and exhaust system, can reduce engine cooling, conceal damage, or increase wear of certain parts. It is important to remove all debris during cleaning.

CAUTION

High pressure washers can damage your motorcycle.

High pressure washers such as those found at coin-operated car washes have enough pressure to damage the parts of your motorcycle. It may cause rust, corrosion and increase wear.

Do not use high pressure washers to clean your motorcycle.

★ WASHING YOUR motorcycle

With some care, your motorcycle can be washed in a similar manner to washing an automobile.

NOTE

Avoid spraying or allowing water to flow over the following places :

- Spark plug
- Fuel tank cap
- Carburetor

Use a garden hose at low pressure to remove the majority of dirt or other debris. Hand wash your motorcycle with a mild soap or detergent and water. Try to thoroughly remove all dirt and debris without excessive water pressure. Cloth rags, washing mitts or cleaning brushes can be used, be careful with brushes as they may scratch plastic or painted surfaces. Rinse the motorcycle thoroughly with clean water. Dry all areas using a chamois or soft absorbent cloth.

★ INSPECTION AFTER CLEANING

Remove the rags or wrapping from the exhaust pipe. For extended life of your motorcycle, lubricate according to "GENERAL LUBRICATION" section.

WARNING

Operating motorcycle with wet brakes can be hazardous.

Wet brakes may not provide as much stopping power as dry brakes. This could lead to an accident.

Test your brakes after washing motorcycle, while riding at slow speed. If necessary, apply brakes several times to let friction dry out the linings and pads.

Follow the procedures in the "INSPECTION BEFORE RIDING" section to check your motorcycle for any problems that may have arisen during your last ride.

LABEL

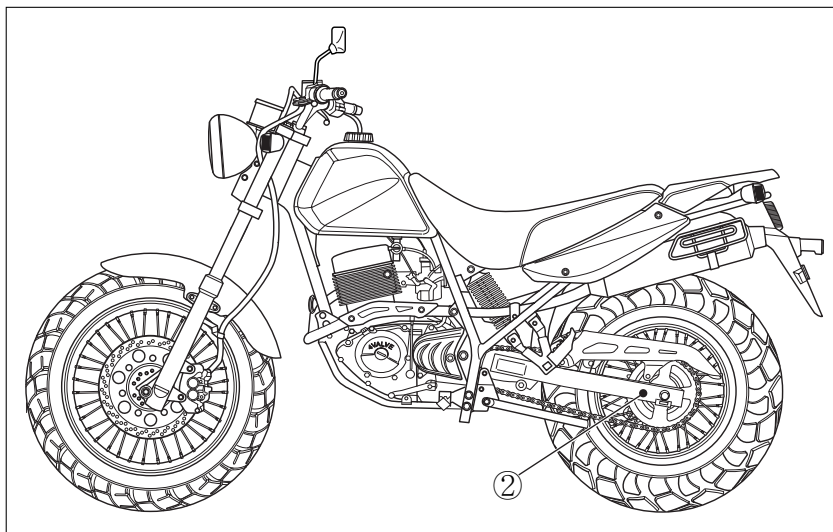
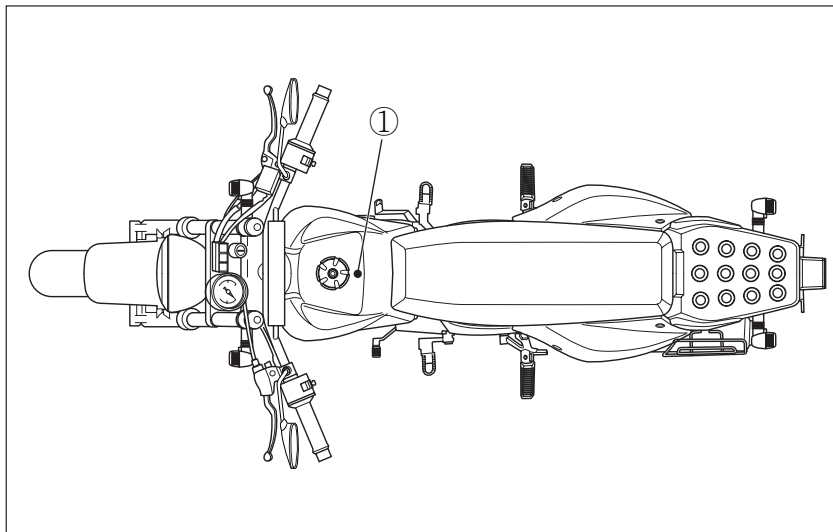

WARNING

- BE FULLY AWARE OF THE OWNER'S MANUAL BEFORE OPERATING AND RIDING.
- MAKE SURE TO WEAR A HELMET.
- OBSERVE THE RESTRICTED SPEED.
- DO NOT BE TOUCHED ON MUFFLER BECAUSE IT IS HOT.
- DO NOT MAKE ILLEGAL MODIFICATION FOR THE SAFE RIDING.
- TAKE THE INSPECTION AND THE MAINTENANCE ACCORDING TO THE REGULAR CHECKLIST OF THE OWNER'S MANUAL
- THE CHECKLIST BEFORE RIDING
- DASHBOARD, HORN, LAMP, OIL, BRAKE, TIRE (AIR PRESSURE, DAMAGE, ABNORMAL WEAR AND ETC.)
- USE THE HYOSUNG GENUINE OIL.

86319H05350-PL

①

WARNING

- AN IMPROPER TIRE PRESSURE CAN CAUSE DIFFICULTIES IN HANDLING, SERIOUS INJURIES OR DEATH.
- BEFORE RIDING, INSPECT THE TIRE PRESSURE, DAMAGE, ABNORMAL WEAR AND ETC. ACCORDING TO THE "INSPECTION BEFORE RIDING"
- ALWAYS MAINTAIN A PROPER TIRE PRESSURE AS SHOWN IN THE BELOW.

	FRONT	REAR
SOLO RIDING	18 psi (1.25kg/cm ²)	18 psi (1.25kg/cm ²)
DUAL RIDING	22 psi (1.50kg/cm ²)	25 psi (1.75kg/cm ²)
TIRE SIZE	130/80-18 66P	180/80-14M/C 78P

86320H05450-PL

②

SPECIFICATIONS

DIMENSIONS AND DRY MASS

Overall length	2,085mm (82.1 in)
Overall width	840mm (33.1 in)
Overall height	1,125mm (44.3 in)
Wheelbase	1,350mm (53.2 in)
Ground clearance	230mm (9.1 in)
Mass	135kg (298 lbs)

ENGINE

Type	Four-stroke, air-cooled
Bore	57.0mm (2.24 in)
Stroke	48.8mm (1.92 in)
Piston displacement	124.5cm ³ (7.58 in ³)
Corrected Compression ratio	9.92:1
Carburetor	Piston valve
Starter system	KICK/SELF STARTER

TRANSMISSION

Clutch	Wet multi-plate type
Reduction ratio	3.375
Drive chain	428HO
Primary	3.05
Transmission	1st : 2.750
	2nd : 1.785
	3rd : 1.368
	4th : 1.045
	5th : 0.913

CHASSIS

Front suspension	Telescopic type
Rear suspension	Swing arm type
Caster	25°
Trail	84mm
Steering angle	47° (right & left)
Front tire size	130/80-18 66P
Rear tire size	180/80-14M/C 78P
Front brake	Disc
Rear brake	Drum

ELECTRICAL

Ignition type	“CDI” type
Ignition timing	15° B.T.D.C.at 2,250 rpm ~ 31° B.T.D.C.at 4,000 rpm
Spark plug	C8EH-9
Battery	12V 6Ah (MF)
Fuse	15A
Headlamp	HI : 12V-35Wx1 LO : 12V-35Wx1
License plate lamp	12V-5Wx1
Turn signal lamp	12V-10Wx4
Brake/Tail lamp	12V-21/5Wx1

CAPACITIES

Fuel tank	9.0 l
Engine oil	950ml (Replace) 1,050ml (Oil filter replace) 1,400ml (Overhaul)



Prepared by

HYOSUNG MOTORS & MACHINERY INC.

Overseas Technical Dept

1st Ed. SEP. 2002.

Printed in KOREA